

# TECHNICAL REPORT SUMMARY ON THE CASA BERARDI MINE, NORTHWESTERN QUÉBEC, CANADA



TECHNICAL REPORT RSI-M0206.22001



PREPARED FOR

Hecla Mining Company  
6500 North Mineral Drive, Suite 200  
Coeur d'Alene, Idaho, USA, 83815

FEBRUARY 2024

[respec.com](http://respec.com)

---

# TECHNICAL REPORT SUMMARY ON THE CASA BERARDI MINE, NORTHWESTERN QUÉBEC, CANADA TECHNICAL REPORT RSI-M0206.22001

## PREPARED BY

RESPEC  
210 South Rock Boulevard  
Reno, Nevada 89502

## PREPARED FOR

Hecla Mining Company  
6500 North Mineral Drive, Suite 200  
Coeur d'Alene, Idaho, USA, 83815

REPORT DATE: FEBRUARY 15, 2024

EFFECTIVE DATE: DECEMBER 31, 2023

Project Number M0206.22001

respec.com

---

## NOTE REGARDING FORWARD-LOOKING INFORMATION

This Technical Report Summary contains “forward-looking statements” within the meaning of Section 27A of the Securities Act of 1933, as amended, and Section 21E of the Securities Exchange Act of 1934, as amended (and the equivalent under Canadian securities laws), which are intended to be covered by the safe harbor created by such sections. Words such as “may”, “will”, “should”, “expects”, “intends”, “projects”, “believes”, “estimates”, “targets”, “anticipates” and similar expressions are used to identify these forward-looking statements. Such forward-looking statements include, without limitation, statements regarding Hecla’s expectation for its mines and any related development or expansions, including estimated cash flows, production, revenue, costs, taxes, capital, rates of return, mine plans, material mined and processed, recoveries and grade, future mineralization, future adjustments and sensitivities and other statements that are not historical facts. Other forward-looking statements in this Report may involve, without limitation, the following:

- / Probable Mineral Reserves that have been modified from Indicated Mineral Resource estimates.
- / Assumed commodity prices and exchange rates.
- / Proposed mine and process production plan.
- / Projected mining and process recovery rates.
- / Ability to market the two types of concentrate on favorable terms as shown in the life of mine plan.
- / Sustaining capital costs and proposed operating costs.
- / Assumptions as to closure costs and closure requirements.
- / Assumptions as to ability to obtain remaining outstanding permits.
- / Assumptions about environmental, permitting and social risks.

The material factors or assumptions used to develop such forward-looking statements or forward-looking information include that the Hecla’s plans for development and production will proceed as expected and will not require revision as a result of risks or uncertainties, whether known, unknown or unanticipated, to which Hecla’s operations are subject. Estimates or expectations of future events or results are based upon certain assumptions, which may prove to be incorrect, which could cause actual results to differ from forward-looking statements. Such assumptions, include, but are not limited to: (i) there being no significant change to current geotechnical, metallurgical, hydrological and other physical conditions; (ii) permitting, development, operations and expansion of Hecla’s projects being consistent with current expectations and mine plans; (iii) political/regulatory developments in any jurisdiction in which Hecla operates being consistent with its current expectations; (iv) the exchange rate for the USD/CAD being approximately consistent with current levels; (v) certain price assumptions for gold, silver, lead and zinc ; (vi) prices for key supplies being approximately consistent with current levels; (vii) the accuracy of our current mineral reserve and mineral resource estimates; (viii) there being no significant changes to Hecla’s plans for 2024 and beyond with respect to availability of employees, vendors and equipment; (ix) Hecla’s plans for development and production will proceed as expected and will not require revision as a result of risks or uncertainties, whether known, unknown or unanticipated; (x) sufficient workforce is available and trained to perform assigned tasks; (xi) weather patterns and rain/snowfall within normal seasonal ranges so as not to impact operations; (xii) relations with interested parties, including First Nations and Native Americans, remain productive; (xiii) maintaining availability of water rights; (xv) factors do not arise that reduce available cash balances; and (xiv) there being no material increases in our current requirements to post or maintain reclamation and performance bonds or collateral related thereto.

i  
i

In addition, material risks that could cause actual results to differ from forward-looking statements include, but are not limited to:

- / Unanticipated reclamation expenses.
- / Unexpected variations in quantity of mineralization, grade or recovery rates.
- / Exploration risks and results, including that mineral resources are not mineral reserves, they do not have demonstrated economic viability and there is no certainty that they can be upgraded to mineral reserves through continued exploration.
- / Geotechnical or hydrogeological considerations during operations being different from what was assumed.
- / Failure of mining methods to operate as anticipated.
- / Operating risks, including but not limited to failure of plant, equipment or processes to operate as anticipated.
- / Accidents and other risks of the mining industry.
- / Silver and other metals price volatility.
- / Currency fluctuations.
- / Increased production costs and variances in ore grade or recovery rates from those assumed in mining plans.
- / Community relations.
- / Conflict resolution and outcome of projects or oppositions.
- / Litigation, political, regulatory, labor, and environmental risks.
- / Inflation causes our costs to rise more than we currently expect.

For a more detailed discussion of such risks and other factors, see Hecla's 2023 Annual Report on Form 10-K. Hecla does not undertake any obligation to release publicly, revisions to any "forward-looking statement," including, without limitation, outlook, to reflect events or circumstances after the date of this presentation, or to reflect the occurrence of unanticipated events, except as may be required under applicable securities laws. Investors should not assume that any lack of update to a previously issued "forward-looking statement" constitutes a reaffirmation of that statement. Continued reliance on "forward-looking statements" is at investors' own risk.

# TABLE OF CONTENTS

1.0	EXECUTIVE SUMMARY	1
1.1	Summary	1
1.1.1	Conclusions	2
1.1.1.1	Geology and Mineral Resources	2
1.1.1.2	Mining and Mineral Reserves	3
1.1.1.3	Mineral Processing	3
1.1.1.4	Infrastructure	4
1.1.1.5	Environment	4
1.1.2	Recommendations	4
1.1.2.1	Geology and Mineral Resources	5
1.1.2.2	Mining and Mineral Reserves	5
1.1.2.3	Mineral Processing	5
1.2	Economic Analysis	5
1.2.1	Economic Criteria	6
1.2.1.1	Physicals	6
1.2.1.2	Revenue	6
1.2.1.3	Capital Costs	7
1.2.1.4	Operating Costs	7
1.2.1.5	Taxation and Royalties	7
1.2.2	Cash Flow Analysis	7
1.2.3	Sensitivity Analysis	9
1.3	Technical Summary	9
1.3.1	Property Description	9
1.3.2	Land Tenure	9
1.3.3	History	10
1.3.4	Geological Setting, Mineralization, and Deposit Types	10
1.3.5	Exploration	11
1.3.6	Mineral Resource Estimates	11
1.3.7	Mineral Reserve Estimates	13
1.3.8	Mining Methods	14
1.3.9	Processing and Recovery Methods	15
1.3.10	Infrastructure	15
1.3.11	Market Studies	16
1.3.12	Environmental Studies, Permitting and Plans, Negotiations, or Agreements with Local Individuals or Groups	17
1.3.13	Capital and Operating Cost Estimates	17

2.0	INTRODUCTION	19
2.1	Site Visit	19
2.2	Sources of Information	20
2.3	Units and Abbreviations	20
3.0	PROPERTY DESCRIPTION	23
3.1	Location	23
3.2	Land Tenure	25
3.3	Encumbrances	28
3.4	Royalties	28
3.5	Other Significant Factors and Risks	28
4.0	ACCESSIBILITY, CLIMATE, LOCAL RESOURCES, INFRASTRUCTURE AND PHYSIOGRAPHY	29
4.1	Topography, Elevation and Vegetation	29
4.2	Climate	29
4.3	Access	29
4.4	Local Resources	29
4.5	Infrastructure	29
5.0	HISTORY	32
5.1	Exploration and Development History	32
5.1.1	1974 to 1996	32
5.1.2	Aurizon (1997 to 2013)	32
5.2	Historical Drilling - 1957 to 2013	34
5.2.1	Historical Drilling – Aurizon, 2006 to 2013	35
5.2.2	Historical Drilling Lake Shore, 2007 to 2012	36
5.2.3	2008	36
5.2.4	2009	37
5.2.5	2010	37
5.2.6	2012	37
5.3	Historical Production	37
6.0	GEOLOGICAL SETTING, MINERALIZATION, AND DEPOSIT	39
6.1	Regional Geology	39
6.2	Property Geology	40
6.2.1	Stratigraphic Divisions	40
6.2.2	Structures	42
6.2.3	Alteration and Metamorphism	44
6.3	Mineralization	45

6.3.1	Styles of Mineralization	45
6.3.2	Veins	45
6.3.3	Stockworks	46
6.3.4	Gold-Bearing Banded Iron Formation	46
6.3.5	Mineralization Near the West Mine Infrastructure	47
6.3.6	Mineralization along the Casa Berardi Fault	49
6.3.7	Mineralization Between the Casa Berardi and South Faults	49
6.3.8	Mineralization at the South Fault	50
6.3.9	Mineralization at the 118 Zone	51
6.3.10	Mineralization at the 123 and 128 Zones	52
6.3.11	Mineralization at the Principal Mine Area	53
6.3.12	Mineralization at the East Mine Area	56
6.4	Deposit Types	59
7.0	EXPLORATION	60
7.1	Hecla Exploration 2014 to 2023	60
7.1.1	2016	60
7.1.2	2017	60
7.1.3	2018	60
7.1.4	2019 and 2020	61
7.1.5	2021	61
7.1.6	2022	62
7.1.7	2023	62
7.2	Drilling Summary	62
7.3	Hecla Drilling, 2014 to 2023	64
7.3.1	Hecla Drilling Protocols	66
7.4	Hydrogeology Drill Holes	68
7.5	Geotechnical Drill Holes	68
7.6	Comments on Drilling	69
8.0	SAMPLE PREPARATION, ANALYSES, AND SECURITY	70
8.1	Drill Sample Handling Procedures and Sample Security	70
8.1.1	Core Sampling	71
8.1.2	Underground Development Heading Samples	71
8.2	Sample Preparation and Analysis	72
8.2.1	Mine Laboratory	72
8.2.2	Swastika	73
8.3	Historical QA/QC Programs	73
8.4	Aurizon/Hecla QA/QC Programs	74
8.4.1	QA/QC Database	74

8.4.2	QA/QC Protocols	74
8.4.3	Pulp Duplicates	74
8.4.4	Pulp External Check Assays	77
8.4.5	Coarse Reject External Check Assays	81
8.4.6	Certified Reference Materials	82
8.4.7	Blanks	95
8.5	Mine Laboratory Internal QA/QC Program	96
8.6	Reverse-Circulation and Sonic Drilling Samples	96
8.7	Conclusions and Recommendations	96
9.0	DATA VERIFICATION	99
9.1	Site Visit	99
9.2	Drill-Hole Database Compilation and Verification by Hecla	99
9.3	Drill-Hole Database Verification by RESPEC	100
9.3.1	Phase 1 – Logic Tests	100
9.3.2	Phase 2 – Assay Data Verification	101
9.4	Comments on Data Verification	101
10.0	MINERAL PROCESSING AND METALLURGICAL TESTING	103
10.1	Introduction	103
10.2	Metallurgical Testing	104
10.2.1	2020 WMCP Test Program	104
10.2.1.1	Sample Preparation and Analyses	104
10.2.1.2	Comminution Testing by SGS	106
10.2.1.3	Gravity Testing by SGS	107
10.2.1.4	Cyanidation Testing by SGS	107
10.2.2	2021 Principal Pit Test Program by Blue Coast	108
10.2.2.1	Sample Preparation and Analyses	108
10.2.2.2	Cyanidation Testing by Blue Coast	109
10.2.3	2021 WMCP Flotation Test Program	110
10.2.3.1	2021 Sample Preparation and Analyses by Blue Coast	110
10.2.3.2	2021 Flotation Testing by Blue Coast	111
10.2.3.3	2021 Cyanidation Testing by Blue Coast	112
10.2.4	2022 WMCP Phase 2 Test Program	113
10.2.4.1	Part 1 – Variability Test Work 2022	114
10.2.4.2	Part 2 – 2022 Master Composite Test Work by Blue Coast	116
10.2.5	2023 WMCP Extension Program by Blue Coast	120
10.2.5.1	2023 Sample Preparation and Analyses	120
10.2.5.2	Flotation Testing	122
10.2.5.3	2023 Gravity Testing by Blue Coast	128

10.2.5.4	2023 Cyanidation Testing by Blue Coast	128
10.2.5.5	Combined Flowsheet Recovery	129
10.3	Sulfide Operation Data	131
10.3.1	Yearly Review	132
10.4	Recovery Models	134
10.4.1	Underground (Zones 115/118/121/123/148)	134
10.4.2	Open Pit	134
10.4.2.1	F134/Principal Pit	134
10.4.2.2	F160 Pit	134
10.4.2.3	WMCP Pit	135
10.5	Expected Recoveries	135
10.6	Deleterious Elements	135
10.7	Conclusions and Recommendations	135
11.0	MINERAL RESOURCE ESTIMATES	137
11.1	Summary	137
11.2	Database	142
11.3	Density Determination	143
11.4	Geological Interpretation	145
11.5	Mineralized Envelope Interpretation	145
11.6	Capping and Compositing	145
11.7	Block Model Dimensions and Coding	146
11.8	Mineral Resource Estimation Methodologies	147
11.9	Mineral Resource Validation	147
11.10	Mineral Resource Classification	147
11.11	Casa Berardi Mineral Resources	150
11.12	Discussion of Mineral Resource Estimates	156
12.0	MINERAL RESERVE ESTIMATES	159
12.1	Underground Mineral Reserves	161
12.2	Open Pit Mineral Reserves	162
12.2.1	F160 Pit	162
12.2.2	WMCP Pit	162
12.2.3	Principal Pit	162
12.2.4	F134 Pit	162
12.3	Cutoff Grade	163
12.4	Dilution and Extraction	163
12.4.1	Underground Mining	163
12.4.2	Open Pit Mining	164
12.5	Estimation Methodology – Open Pit Projects	165

12.5.1	F160 Pit	165
12.5.2	WMCP Pit	166
12.5.3	Principal Pit	166
12.5.4	F134 Pit	166
12.6	Comparison to Previous Estimates	167
12.7	Reconciliation	168
13.0	MINING METHODS	175
13.1	Mining Operations – Underground	175
13.1.1	Underground Development	175
13.1.1.1	Ground Support	175
13.1.1.2	Development Performance	176
13.1.1.3	Mine Design	176
13.1.2	West Mine and Principal Area	176
13.1.3	Transverse Method	177
13.1.4	Longitudinal Method	178
13.1.5	Stope Size	179
13.1.6	East Mine Mining History	180
13.1.7	Backfill	180
13.1.8	Mine Equipment	181
13.2	Ground Stability	181
13.2.1	Ground Conditions	181
13.2.2	Ground Testing and Analysis	182
13.2.3	Operating Practices	182
13.3	Mine Infrastructure	183
13.3.1	West Mine Shaft	183
13.3.2	Ore and Waste Pass Systems	186
13.3.3	Ventilation	186
13.3.4	Maintenance Facilities	188
13.3.5	Power	188
13.3.6	Personnel	190
13.4	Open Pit Mining Operations	192
13.4.1	Mining Method	192
13.4.2	Open Pit Design	192
13.4.3	Slope Parameters – Overburden	193
13.4.4	Slope Parameters - Rock	193
13.4.5	Ramp Design	193
13.4.6	Underground Workings	194
13.4.7	Open Pit Mining Equipment	194
13.4.8	Geotechnical/Hydrogeological Considerations	195

13.4.9	Material Management	201
13.4.10	Waste Rock Characterization	201
13.4.11	Waste Rock Facility Locations and Construction	201
13.4.12	Overview of Open Pits	205
13.4.12.1	F160 Pit	205
13.4.12.2	F134 Pit	207
13.4.12.3	WMCP Pit	208
13.4.12.4	Principal Pit	210
13.5	Long-Range Plan	212
13.6	Life of Mine Plan	212
14.0	PROCESSING AND RECOVERY METHODS	214
14.1	Introduction	214
14.2	Process Description	214
14.2.1	Crushing	215
14.2.2	Grinding	215
14.2.3	Gravity Circuit	215
14.2.4	CIL Circuit	215
14.2.5	Carbon Circuit	216
14.2.6	Elution and Electrowinning Circuits	216
14.2.7	Major Equipment List	217
14.3	Energy, Water, and Process Materials Requirements	218
14.4	Personnel	219
15.0	INFRASTRUCTURE	220
15.1	Roads and Logistics	220
15.1.1	Tailings Management and Facilities	226
15.1.2	Waste Rock Management and Stockpiles	227
15.1.3	Waste rock and overburden	227
15.1.4	Other Wastes	228
15.1.5	Water Supply	228
15.1.6	Water Use	228
15.1.7	Power and Electrical	228
15.1.8	Fuel	228
16.0	MARKET STUDIES	229
16.1	Markets	229
16.1.1	Overview	229
16.1.2	Commodity Price Projections	229
16.2	Contracts	230
16.2.1	Refining	230

16.2.2	Other Contracts	230
17.0	ENVIRONMENTAL STUDIES, PERMITTING, AND PLANS, NEGOTIATIONS, OR AGREEMENTS WITH LOCAL INDIVIDUALS OR GROUPS	231
17.1	Environmental Considerations	231
17.2	Water Management and Effluent Treatment	232
17.2.1	Water Management	232
17.2.2	Mine Water Management	234
17.2.3	TSF Water Management	234
17.2.4	Environmental Effects of Treated Effluent	234
17.3	Regulatory Change and Environmental Permits	234
17.3.1	Regulatory Change	234
17.3.2	Environmental Permits	235
17.3.3	Environmental Impact Assessment	250
17.4	Mine Reclamation and Closure	250
17.5	Community and Social Aspects	251
17.6	Comments on Environmental Studies, Permitting, and Community Impact	251
18.0	CAPITAL AND OPERATING COSTS	253
18.1	Capital Costs	253
18.2	Operating Costs	255
18.2.1	LOM Operating Costs	256
19.0	ECONOMIC ANALYSIS	258
19.1	Economic Criteria	258
19.1.1	Physicals	258
19.1.2	Revenue	259
19.1.3	Capital Costs	259
19.1.4	Operating Costs	259
19.1.5	Taxation and Royalties	259
19.2	Cash Flow Analysis	260
19.3	Sensitivity Analysis	264
20.0	ADJACENT PROPERTIES	267
21.0	OTHER RELEVANT DATA AND INFORMATION	267
22.0	INTERPRETATION AND CONCLUSIONS	267
22.1	Geology and Mineral Resources	267
22.1.1	Geology, Mineralization and Deposit Types	267
22.1.2	Adequacy of Data Used in Estimating the Project Mineral Resources	267
22.1.3	Mineral Resources	268

22.1.4	Exploration Potential	269
22.2	Mining and Mineral Reserves	269
22.3	Mineral Processing	270
22.4	Infrastructure	270
22.5	Environment	270
23.0	RECOMMENDATIONS	271
23.1	Geology and Mineral Resources	271
23.2	Mining and Mineral Reserves	272
23.3	Mineral Processing	272
24.0	REFERENCES	273
25.0	RELIANCE ON INFORMATION PROVIDED BY THE REGISTRANT	278
26.0	DATE AND SIGNATURE PAGE	279
APPENDIX A	CLAIMS TABLE	1-A
A.1	Claims Table	2-A
APPENDIX B	DRILL-HOLE AND ROCK-CHIP SAMPLE DATABASE STRUCTURES	1-B
B.1	Drill-Hole and Rock-Chip Sample Database Structures	2-B
APPENDIX C	CAPPING LEVELS	1-C
C.1	Capping Levels	2-C
APPENDIX D	COMPARISON OF 2023 AND 2022 MINERAL RESOURCE ESTIMATES	1-D
D.1	Mineral Resource Estimates	2-D

# LIST OF TABLES

Table 1-1. Life of Mine Indicative Economic Results	8
Table 1-2. Mineral Resource Estimate Summary – December 31, 2023	12
Table 1-3. Summary of Mineral Reserves - December 31,2023	14
Table 1-4. LOM Capital Cost Summary	18
Table 1-5. LOM Operating Cost Summary	18
Table 5-1. Historical Drilling 1957 through 2013	34
Table 5-2. Historical Mine Production 1988 – 1997	38
Table 5-3. Casa Berardi Production 2006 to mid-2013	38
Table 7-1. Hecla Surface and Underground Drilling 2014 – 2023	64
Table 7-2. Hydrogeological Drill Holes Between 2022 & 2023	68
Table 7-3. Geotechnical Drill Holes from 2022-2023	69
Table 8-1. Pulp Duplicate Summary from 2009 to 2023	76
Table 8-2. External Check Assays from 2009 to 2023	78
Table 8-3. Reject External Check Assays	81
Table 8-4. CRM Assay Results	86
Table 8-5. Casa Berardi Laboratory Program CRMs	96
Table 10-1. Chemical Assays of Composite Samples	105
Table 10-2. Comminution Test Results on Composites	107
Table 10-3. Head Grade Summary	109
Table 10-4. Head Grade Summary, 2021 Blue Coast Work	111
Table 10-5. 2021 WMCP Flotation Test Conditions	111
Table 10-6. 2021 WMCP Flotation Product CIL Stirred Leach Conditions	112
Table 10-7. Summary of 2021 WMCP Flotation Product CIL Stirred Leach Results	113
Table 10-8. 2022 WMCP Variability Cyanidation Results	115
Table 25. 2022 Casa Berardi WMCP Master Composite Head Assays	117
Table 10-10. 2022 Flotation Conditions	118
Table 10-11. 2023 Casa Berardi WMCP Master Composite Head Assays	121
Table 10-12. Summary of 2023 Flotation Test Conditions	124
Table 10-13. Combined Flowsheet Recovery – Non Final Flowsheet	130
Table 10-14. Combined Flowsheet Recovery –Final Flowsheet	131
Table 10-15. Casa Berardi Annual Mill Production	132
Table 10-16. Detailed Yearly Mill Production	133

x  
x

Table 10-17. Expected Recovery LOM for all Mining Zones	135
Table 11-1. Casa Berardi Mineral Resource Estimate Summary – December 31, 2023	139
Table 11-2. Open Pit Optimization Parameters Applied to Mineral Resources	140
Table 11-3. Comparison of December 31, 2023 Versus December 31, 2022 Mineral Resources	141
Table 11-4. Summary of Core, Reverse Circulation and Sonic Drill Holes and Channel Samples at Casa Berardi	142
Table 11-5. Descriptive Statistics of Sample Assays in Casa Berardi Drill-Hole Database	143
Table 11-6. Density Determinations by Zone	144
Table 11-7. Open Pit Optimization Parameters by Pit	151
Table 11-8. Underground Mineral Resource Cutoff Grades by Zone	152
Table 11-9. Underground and Open Pit Mineral Resources by Zone – December 31, 2023	152
Table 12-1. Summary of Mineral Reserves – December 31, 2023	159
Table 12-2. Mineral Reserves by Zone – December 31, 2023	160
Table 12-3. Underground and Open Pit Reserve Cutoff Grades	163
Table 12-4. Dilution and Extractions Estimates – Underground	164
Table 12-5. Dilution and Extractions Estimates – Open Pit	165
Table 12-6. Change in Mineral Reserves 2023 to 2022	167
Table 12-7. Mine-Mill Reconciliation – 2006 to 2023	169
Table 12-8. Mine-Mill Reconciliation – 2006 to 2023	170
Table 12-9. Mine-Mill Reconciliation – 2023	171
Table 12-10. Mine-Mill Reconciliation – 2023	172
Table 13-1. Tonnage per Stope	179
Table 13-2. Typical Stope Delays and Activity Duration	179
Table 13-3. Personnel Requirements by Year	191
Table 13-4. Mine Equipment List Open Pit	195
Table 13-5. Geotechnical, Geomechanical, Hydrological and Hydrogeological Studies (Underground Mines)	197
Table 13-6. Geotechnical, Geomechanical, Hydrological and Hydrogeological Studies (Open Pit Mines)	198
Table 13-7. Dumping Sequencing	203
Table 13-8. LOM Production Forecast	213
Table 14-1. Major Equipment List	217
Table 14-2. Reagent Consumption 2023	219
Table 16-1. Hecla Historical Average Realized Metal Prices	229
Table 17-1. Existing Environmental Permits	236
Table 17-2. Total Contributions to Regional Organizations from 2018 to 2022	251
Table 18-1. LOM Capital Costs	254

Table 18-2. 2020 and 2021 Operating Cost Data	256
Table 18-3. LOM Operating Costs	257
Table 18-4. LOM Unit Operating Costs	257
Table 19-1. Annual Cash Flow Model	261
Table 19-2. Sensitivity Analysis Summary	265

## LIST OF FIGURES

Figure 1-1. Mine Plan View of Current and Planned Infrastructure with Composite Longitudinal Section	2
Figure 3-1. Project Regional Location Map	23
Figure 3-2. Property Location Map	24
Figure 3-3. Plan View of Current and Planned Infrastructure	25
Figure 3-4. Property Claim Map	27
Figure 4-1. Surface Infrastructure	31
Figure 6-1. Regional Geology of Northwestern Québec, Canada	40
Figure 6-2. Casa Berardi Property Geology	41
Figure 6-3. Property Stratigraphic Divisions	42
Figure 6-4. Mine Area Surface Geology	44
Figure 6-5. Section 11,385E, West Mine Including the 113 Zone and Casa Berardi Fault	48
Figure 6-6. Section 10,800E, West Mine Geology and Mining Infrastructure	50
Figure 6-7. Plan View of the 1,010m Level, Principal Area	52
Figure 6-8. Section 12,330E, Principal Area Geology 118, 123, and 124 Zones	53
Figure 6-9. Plan View of the 290m Level, Principal Area Including the 124 Zone Lenses	55
Figure 6-10. East Mine Composite Longitudinal Section	57
Figure 6-11. Section 15, 840E, East Mine Geology and Infrastructure – 160 Zone	58
Figure 7-1. Map of all Historical and Hecla Diamond Core, RC, and Sonic Drilling	63
Figure 8-1. Mine Laboratory Pulp Duplicate Assays from 2021- 2023	77
Figure 8-2. Mine Laboratory Pulp External Check Assays at ALS (2021-2023)	80
Figure 8-3. Swastika Pulp External Check Assays at ALS (2021-2023)	80
Figure 8-4. Plot of 2023 CRM Assays from the Mine Lab for OREAS 235	83
Figure 8-5. Plot of 2023 CRM Assays from Swastika for OREAS 235	84
Figure 8-6. Plots of All CRM Assay Results from 2006 to 2023	85
Figure 8-7. Mine and Swastika Blanks – 2023	95
Figure10-1. Mineralogical Analyses on Composites	106

Figure10-2. Flowsheet Originally Developed	123
Figure 10-3. WMCP Blend Simplified Integrated Flowsheet	128
Figure 11-1. Mine Plan View and Composite Longitudinal Section of Deposit Areas and Infrastructure	138
Figure 12-1. Tonnage Reconciliation 2016 to 2023 Annual	173
Figure 12-2. Grade Reconciliation 2016 to 2023 Annual	173
Figure 12-3. Contained Gold Reconciliation 2016 to 2023 Annual	174
Figure 13-1. Transverse Mining Method	178
Figure 13-2. West Mine Surface Infrastructure	184
Figure 13-3. East Mine Surface Infrastructure	185
Figure 13-4. West Mine - Ventilation Schematic Circuit	187
Figure 13-5. Casa Berardi Main Station 120kV Flowsheet	190
Figure 13-6. Open Pit and Waste Rock Locations	203
Figure 13-7. Plan View of the F160 Pit Project	206
Figure 13-8. Plan View of the F134 Pit (Ultimate Pit Shell)	207
Figure 13-9. Plan View of the WMCP Pit Project (Ultimate Pit Shell)	209
Figure 13-10. Plan View of the Principal Pit Project (Ultimate Pit Shell)	211
Figure 14-1. Mill Flowsheet	214
Figure 15-1. Surface Infrastructure (Current and Preliminary)	221
Figure 15-2. East Mine Surface Infrastructure	223
Figure 15-3. West Mine Surface Infrastructure	225
Figure 15-4. Surface Plan Tailings and Waste Rock Facilities	226
Figure 17-1. Water Management Flow Sheet	233
Figure 19-1. After-tax NPV at 5% Sensitivity Analysis	266

# 1.0 EXECUTIVE SUMMARY

## 1.1 SUMMARY

RESPEC was retained by Hecla Mining Company (Hecla) to prepare an independent Technical Report Summary (TRS) on the Casa Berardi Mine (Casa Berardi, mine, or the Property), located in Québec, Canada. The purpose of this TRS is to support the disclosure of the Casa Berardi Mineral Resource and Mineral Reserve estimates as of December 31, 2023. This TRS conforms to the United States Securities and Exchange Commission's (SEC) Modernized Property Disclosure Requirements for Mining Registrants as described in Subpart 229.1300 of Regulation S-K, Disclosure by Registrants Engaged in Mining Operations (S-K 1300) and Item 601 (b)(96) Technical Report Summary. RESPEC visited the Property on September 19 -21, 2023.

Hecla was established in 1891 and has its headquarters in Coeur d'Alene, Idaho, USA. In June 2013, Hecla acquired Aurizon Mines Ltd. (Aurizon) and renamed the company Hecla Québec Inc. (Hecla Québec). Hecla has an administrative/exploration office in Val-d'Or, Québec and an office in Vancouver, British Columbia. Hecla holds a 100% interest in Casa Berardi through its wholly owned subsidiary Hecla Québec. The Casa Berardi complex has a 35-year history of surface and underground mining operations.

The Property is located in northwestern Québec, approximately 95km north of the town of La Sarre, in the James Bay Municipality. The Property extends east-west for more than 37km and is 3.5km wide in a north-south direction. The Property is bounded to the west by the Québec/Ontario border and covers parts of Casa Berardi, Dieppe, Raymond, D'Estrières, and Puiseaux townships. The Casa Berardi gold deposits are located along a five kilometer east-west mineralized corridor associated with the Casa Berardi Fault. They comprise the West Mine, including the Principal area, and the East Mine.

The Casa Berardi gold deposits can be classified as an Archean sedimentary hosted lode gold deposit. The gold mineralization is superimposed on a continuous graphitic mudrock unit corresponding to the Casa Berardi Fault plane. Gold occurs mainly south of the Casa Berardi Fault, and occasionally on both sides of the fault.

The Casa Berardi operation includes several open pits and two underground mines (Figure 1-1). The mine has produced approximately 3.06 million ounces (Moz) Au (recovered) since commencing production in 1988, including approximately 2.37Moz Au (recovered) since production recommenced in November 2006.

The Casa Berardi processing facilities consists of a 3,730tonnes per day (tpd) mill, with the ability to process 4,400tpd, and a carbon-in-leach (CIL) process to recover gold from the ore.

Production for Casa Berardi over the current life of mine (LOM), 2024 to 2037, is forecast to be comprised of 209 thousand tonnes (kt) from the underground operations in 2024 and 14.2 million tonnes (Mt) from the open pit operations from 2024 until 2037.

**Figure STYLEREF 1 \s 1-. Mine Plan View of Current and Planned Infrastructure with Composite Longitudinal Section**

1  
1

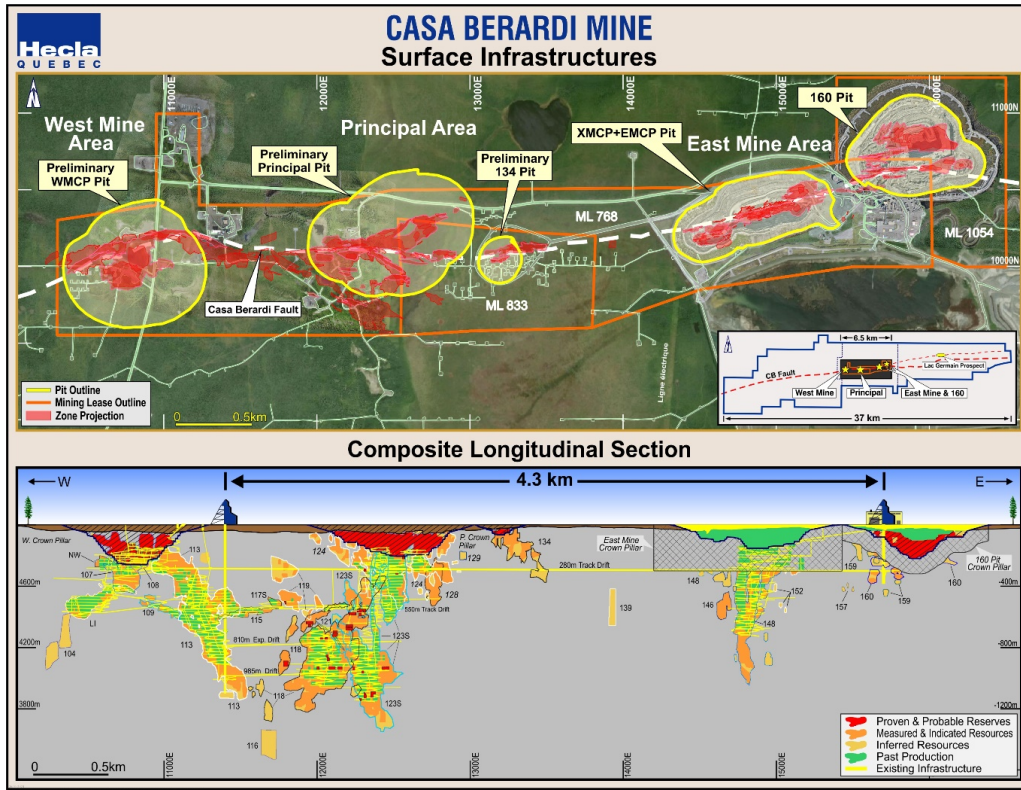

### 1.1.1 CONCLUSIONS

RESPEC offers the following conclusions and observations by area:

#### 1.1.1.1 GEOLOGY AND MINERAL RESOURCES

- / The Casa Berardi Property is located in the northern part of the Abitibi Subprovince, within the Superior Province of the Archean core of the Canadian Shield. Three principal styles of mineralization have been recognized at Casa Berardi with gold occurring in: 1) quartz veins, 2) stockworks, and 3) banded iron formation. The mineralized zones are closely associated with the Casa Berardi Fault, and the Casa Berardi deposit can be classified as an Archean-age, sedimentary-hosted lode-gold deposit.
- / Compilation and subsequent verification of the Casa Berardi database has been performed by Hecla personnel since 2014. To further evaluate Hecla's database, RESPEC conducted an audit of all 2021, 2022 and 2023 assay data, with acceptable results. RESPEC is satisfied that the drill-hole database is considered to be sufficient for use in geological and mineral domain modeling, Mineral Resource and Mineral Reserve estimation, and mine planning.
- / Measured and Indicated resources, effective December 31, 2023, consist of a total of 4.11Mt with an average gold grade of 6.39g Au/t containing 0.84Moz Au. Inferred Mineral Resources total 2.09Mt at 5.89g/t Au for

2  
2

0.40Moz Au. The open pit resources are constrained within the designed pit while underground material was constrained by stope optimizations, reflecting the potential for underground and open pit mining and mill processing of the present Casa Berardi deposits.

- / Hecla considered density and quality of drill-hole data, the established continuity of the auriferous zones, and production experience in classification of the Casa Berardi gold Mineral resources in the open pit and underground block models. RESPEC has evaluated Hecla's classification for the Casa Berardi Mineral Resources and concludes that their applied methodologies are reasonable and satisfy S-K 1300 requirements.

#### 1.1.1.2 MINING AND MINERAL RESERVES

- / Mineral Reserves have been classified in accordance with the definitions for Mineral Reserves in S-K 1300. Mineral Reserves as of December 31, 2023, total 14.4Mt grading 2.75g/t Au containing 1.27Moz Au.
- / Measured and Indicated Mineral Resources were converted to Proven and Probable Mineral Reserves, respectively. Inferred Mineral Resources were not converted to Mineral Reserves.
- / The mining methods at Casa Berardi are well established with many years of operating experience, providing the necessary expertise to, safely and economically, extract the Mineral Reserves.
- / While both transverse and longitudinal longhole stoping methods are employed underground. Challenging ground conditions require the use of various types of backfill to provide the necessary support.
- / Underground mining will come from the West Mine in 2024 as the East mine was abandoned in 2023 to allow for backfilling the adjoining EMCP pit. Mining from various open pits on surface represents the bulk of the Mineral Reserves to be mined, accounting for approximately 98.5% of the Casa Berardi Mineral Reserves.
- / The current LOM period is estimated to be 14 years ending in 2037. Underground Mineral Reserves totaling 209kt are planned be mined in 2024 while open pit Mineral Reserves totaling 14.2Mt is planned be mined over the entire LOM period.
- / The LOM plan considers a 30-month delay in mining to allow for the expected permitting timeline.

#### 1.1.1.3 MINERAL PROCESSING

- / Metallurgical and production models have been developed from extensive baseline sampling and are further adjusted annually to account for process and metallurgical improvements and changes.
- / The test work performed on open pit material was used to estimate gold recovery, while operating data was used for underground material. Extensive test work has been performed by an external laboratory on future open pit material (West Mine Crown Pillar (WMCP) and Principal). WMCP test results were used to inform the long-term mine plan.
- / Test work programs, both internal and external, continue to be performed to support current operations and potential improvements.
- / The current process facilities are appropriate for the mineralization material extracted from the mine. The flowsheet, equipment, and infrastructure are expected to support the current LOM plan.

#### 1.1.1.4 INFRASTRUCTURE

- / Hecla is currently mining at Casa Berardi and has both open pit and underground infrastructure, as well as a mill. Hecla plans to develop three additional open pits (Principal, WMCP, and F134) and associated waste rock storage facilities, and other surface infrastructure for future mine operations.

3  
3

/ With the increase of pit production, an expanded maintenance facility will be required. A capital allowance is included in cashflow model.

#### 1.1.1.5 ENVIRONMENT

- / Hecla has sufficiently assessed the environmental impact of the operation, and subsequent closure and remediation requirements such that Mineral Resources and Mineral Reserves can be declared, and the mine plan deemed appropriate and achievable. Closure provisions are appropriately considered, and monitoring programs are in place.
- / Hecla has developed a community relations plan to identify and ensure an understanding of the needs of the surrounding communities and to determine appropriate programs for addressing those needs. Hecla appropriately monitors socio-economic trends, community perceptions, and mining impacts.
- / Current permits held by Hecla for the Property are sufficient to ensure that the planned surface and underground mining activities which will take place into 2026 are conducted in accordance with the local, provincial, and national regulatory frameworks.
- / Beyond 2026, the LOM plan includes the development of three additional open pits along with associated waste rock storage facilities and other infrastructure. This planned development may require an EIA to be performed at the Property. Hecla will submit a project notice to the Provincial MELCCFP in 2024 that describes the proposed development and proposed plan of operations. Hecla expects the EIA process that all necessary permits will be obtained so that mining of the planned open pits can take place in accordance with local, provincial, and national regulatory frameworks.
- / There are currently no known environmental, permitting, or social/community risks that could impact the Mineral Resources or Mineral Reserves.

#### 1.1.2 RECOMMENDATIONS

RESPEC offers the following recommendations by area.

4  
4

### 1.1.2.1 GEOLOGY AND MINERAL RESOURCES

- / Continue drilling to expand the near mine open pit Mineral Resources.
- / Convert open pit and underground Inferred Mineral Resources to Indicated, especially material in the Life of Mine Plan.
- / Continue to drill below the F134 and F160 pits.
- / Create resource open pit shells for F134 and F160.
- / Increase regional exploration activities to make new discoveries on the Property.
- / Investigate the potential high gold assay bias at the secondary umpire laboratory.
- / Implement procedures that will help reduce certified reference material (CRM or standard) mislabeling or “swaps”.

### 1.1.2.2 MINING AND MINERAL RESERVES

- / Review marginal underground Mineral Resources for extraction due to higher spot prices in the near term.
- / Continue to convert Mineral Resources to Mineral Reserves to extend open pit mining where possible.
- / Continue to develop a ramp up plan to reach maximum mining rates after restart.
- / Since the existing cost model is based on contractor rates, an evaluation of a complete haulage model will provide a more comprehensive understanding of late-stage owner operator costs. It would be expected that mining operating costs could be lowered for future studies.

### 1.1.2.3 MINERAL PROCESSING

- / Continue to conduct additional metallurgical testing to better understand the processing of mineralization from the Principal and WMCP pits. This will aid in projecting metallurgical recoveries for these pits and will indicate any variability in gold recovery and grindability of the material.

## 1.2 ECONOMIC ANALYSIS

Please refer to the note regarding forward-looking information at the start of this Report.

The economic analysis contained in this TRS is based on the Casa Berardi Proven and Probable Mineral Reserves material only, economic assumptions, and capital and operating costs provided by Hecla’s technical team in its LOM plan model and reviewed by RESPEC. All costs in this section are expressed in US dollars. Unless otherwise stated, all costs in this section of the TRS are expressed without allowance for escalation or currency fluctuation. All costs received from Hecla’s site technical team in its Casa Berardi LOM 2023 Reserves only model were quoted in Canadian dollars and were converted to US dollars at an exchange rate of US\$1 = C\$1.350.

A summary of the key project criteria is provided in the subsequent subsections.

## 1.2.1 ECONOMIC CRITERIA

### 1.2.1.1 PHYSICALS

- / Mine life: 14 year LOM (between years 2024 and 2037)
- / Open Pit operations
  - » Open pit mine life: 14 years (between years 2024 and 2037)
  - » Total ore tonnes mined: 14.2Mt at 2.72g/t Au
  - » Waste tonnes: 219Mt
  - » Maximum mining rate: 87ktpd (ore + waste)
- / Underground operations
  - » Underground mine life: 1 year (2024)
  - » Total ore tonnes mined: 209kt at 4.84g/t Au
  - » Maximum mining rate: 1,200tpd
- / Processing of Mineral Reserves:
  - » Total Ore Feed to Plant: 14.4Mt
    - Gold grade: 2.75g/t Au
  - » Maximum milling rate: 4,400tpd
  - » Contained Metal
    - Gold: 1.27Moz Au
  - » Average LOM Plant Recovery 81.5%
  - » Recovered Metal
    - Gold: 1.04Moz Au

### 1.2.1.2 REVENUE

- / For the purposes of this economic analysis described in this section, revenue is estimated over the LOM with a flat long-term price of US\$1,950/oz Au. RESPEC considers this price to be aligned with the latest industry consensus long-term forecast prices. Transportation, insurance, and refining charges are estimated at US\$4.07/oz Au over the LOM. Payable metals in the Casa Berardi LOM 2024 plan are estimated at 99.9% for gold and 99.0% for silver. These rates are based on actual figures for refining losses. Silver credits have been estimated based on historical performance of the site.
- / LOM net revenue is US\$2,019 million (after Refining Charges).

### 1.2.1.3 CAPITAL COSTS

- / Total operating capital costs total US\$498 million
- / Closure costs of US\$21.6 million and a salvage value of \$19.7 million are included in the analysis at the end of the LOM.

### 1.2.1.4 OPERATING COSTS

- / Open Pit mining: US\$26.45/t ore mined
- / Underground mining: US\$106.23/t ore mined
- / Processing: US\$22.96/t ore milled
- / G&A US\$4.99/t ore milled
- / Total unit operating costs US\$55.45/t ore milled
- / LOM total operating costs US\$797.6 million
- / Excludes financing and corporate overhead costs

### 1.2.1.5 TAXATION AND ROYALTIES

- / Royalties: The current production zones as well as any in the 2024 LOM are not subject to a net smelter return (NSR) or royalty to a third party / previous landowner.
- / Income tax is payable to the Federal Government of Canada, pursuant to the Income Tax Act (Canada). The applicable Federal income tax rate is 15% of taxable income.
- / Income tax is payable to the Province of Québec at a tax rate of 11.5% of taxable income.
- / No income taxes are payable until 2031 as Hecla uses its current tax pools and net operating loss carry forwards. Beginning in 2031, the effective tax rate used is 26.5% (combined federal and provincial).
- / Québec Mining Tax base rate is 16%.

## 1.2.2 CASH FLOW ANALYSIS

RESPEC has reviewed and accepts Hecla's cash flow model as discussed in this section.

The Casa Berardi economics have been evaluated using the discounted cash flow method by considering annual processed tonnages and grade of ore. The associated process recovery, metal prices, operating costs, refining and transportation charges, and sustaining capital expenditures were also considered.

The full annual cash flow model is presented in Table 1-1 in US dollars with no allowance for inflation, show a pre-tax and after-tax NPV, using a 5% discount rate, of \$429 million and \$356 million, respectively. RESPEC is of the opinion that a 5% discount/hurdle rate for after-tax cash flow discounting of long-lived precious/base metal operations in a politically stable region is reasonable and appropriate and commonly used. For this cash flow analysis, the internal rate of return (IRR) and payback are not applicable as there is no negative initial cash flow (no initial investment to be recovered) since Casa Berardi has been in operation for a number of years.

7  
7

**Table STYLEREF 1 \s 1-. Life of Mine Indicative Economic Results**

	Units	Total LOM
<b>Production</b>		
LOM	years	14
OP Production	000t	14,174
Au Grade	g/t	2.72
Waste	000t	233,628
UG Production	000t	209
Au Grade	g/t	4.84
Mill Feed	000t	14,383
Au Grade	g/t	2.75
Ag Grade	g/t	0.66
Ag/Au Conversion Ratio	%	23.999
<b>Total Contained Production</b>		
Contained Au	000oz	1,270
Contained Ag	000oz	305
Average Recovery	%	81.5
<b>Total Recovered Production</b>		
Recovered Au	000oz	1,036
Recovered Ag	000oz	249
<b>Metal Prices</b>		
Gold Price	US\$/oz	1,950
Silver Price	US\$/oz	22
<b>Cash Flow</b>		
Gross Revenue	US\$ million	2,023
Treatment & Refining	US\$ million	-4
<b>Operating Costs</b>		
Mining OP Costs	US\$ million	-373
Mining UG Costs	US\$ million	-22
Processing Costs	US\$ million	-330
G&A	US\$ million	-72
Operating Cash Flow	US\$ million	1,221
Growth Capital Costs	US\$ million	-421
Sustaining Capital Costs	US\$ million	-77
Salvage Value	US\$ million	20
Reclamation & Closure	US\$ million	-22

	Units	Total LOM
Pre-Tax Net Cash Flow	US\$ million	721
Québec Mining Tax	US\$ million	-44
Federal & Provincial Income Taxes	US\$ million	-75
After-Tax Cashflow	US\$ million	602
Project Economics		
Pre-tax NPV at 5%	US\$ million	429
After-Tax NPV at 5%	US\$ million	356
Operating Metrics		
Maximum Daily OP Mining Rate	t/d mined	87,000
Maximum Daily UG Mining Rate	t/d mined	1,200
Maximum Daily Processing Rate	t/d milled	4,400
OP Mining Cost	US\$/t ore mined	26.45
UG Mining Cost	US\$/t ore mined	106.23
Processing Cost	US\$/t ore	22.96
G&A Cost	US\$/t ore	4.99
Total Cost	US\$/t ore	55.45

### 1.2.3 SENSITIVITY ANALYSIS

Project risks can be identified in both economic and non-economic terms. Key economic risks were examined by running cash flow sensitivities on after-tax NPV at a 5% discount rate. The mine is most sensitive to changes in metal prices and US\$/C\$ exchange rate, then capital costs and operating costs.

## 1.3 TECHNICAL SUMMARY

### 1.3.1 PROPERTY DESCRIPTION

The Property is located in the Province of Québec, approximately 95km north of the town of La Sarre, in the James Bay Municipality. The mine is located at longitude 79°16'46.4" and latitude 49°33'56.7".

### 1.3.2 LAND TENURE

The Property consists of 391 contiguous designated claims, covering a total area of 19,151.08ha, and three mining leases, BM 768, BM 833, and BM 1054 covering areas of 397.09ha, 84.35ha, and 92.56ha, respectively. The Property area totals 19,725.08ha. Other legal titles include non-exclusive lease BNE 25938, tailings lease 70218, and two waste rock facility (WRF) leases 192410 and 819410. Legal titles are under the name of Hecla Québec. The Casa Berardi claims are in good standing.

9  
9

### 1.3.3 HISTORY

Prior to 1974, the Casa Berardi area was explored for base metal deposits. In 1974, the first 13 claims were staked by Inco Gold Ltd. (Inco Gold). The discovery hole was drilled in 1981, and 590 additional claims were staked.

In 1982, Inco Gold (60%) and Golden Knight Resources Inc. (Golden Knight) (40%) formed a joint venture (JV) to operate the Mine, with the East Mine commencing production in 1988 and the West Mine in 1990. In 1991, TVX Gold Inc. (TVX) acquired Inco Gold's 60% interest in the Property. In 1994, TVX and Golden Knight purchased the remaining interest in the Domex claim block, a part of the Principal (Main) Zone between the West Mine and East Mine, from Teck Corporation. In January 1997, TVX announced the closure of the East Mine due to ground control issues. Two months later, the West Mine was closed. The total combined production for the period from 1988 to 1997 was 3.5Mt at an average grade of 7.1g/t Au. The total gold recovered during the operating years was 688,400toz Au, with an average mill gold recovery rate of 87%.

In September 1998, Aurizon signed an agreement and completed the acquisition of all Casa Berardi assets and mining rights. Aurizon completed exploration diamond drilling programs, feasibility studies, underground development, shaft sinking, and construction.

In early November 2006, Aurizon completed construction and development at the West Mine area and commenced underground mining and milling operations. From November 2006 to May 31, 2013, Aurizon production totaled approximately 4.31Mt at an average grade of 7.7g/t Au for a total of 0.98Moz Au recovered.

In June 2013, Hecla acquired Aurizon and the company was renamed Hecla Québec, a 100% subsidiary of Hecla. By 2012, Lake Shore Gold Inc. (Lake Shore) earned into a 50% interest in certain claims and mineral rights within the Casa Berardi Exploration Property (Casa Exploration Property), but not in areas where production was occurring, pursuant to a 2007 option agreement between the parties. In February 2016, Tahoe Resources Inc. (Tahoe) purchased Lake Shore, and at the end of 2016, they opted to sell their 50% interest in the Casa Exploration Property to Hecla in exchange for C\$6 million (US\$ 4,433,400 million) and 1% NSR on 227 claims. Hecla Purchased the NSR from Lake Shore in December 2016 and repurchased the related 1% NSR in June 2021. From June 1, 2013 to December 31, 2021, production from Casa Berardi totaled approximately 9.0Mt at an average grade of 4.88g/t Au for a total of 1.17Moz Au recovered.

Since 1988, a total of 19.8Mt at an average grade of 5.49g/t Au have been milled at Casa Berardi for a total recovered gold of 3.1Moz Au and an average gold recovery of 87.8%

### 1.3.4 GEOLOGICAL SETTING, MINERALIZATION, AND DEPOSIT TYPES

The Casa Berardi Property is located in the northern part of the Abitibi Sub province, within the Superior Province of the Archean core of the Canadian Shield. The regional geology is characterized by generally east-west assemblages of isoclinally folded and variably foliated and metamorphosed mafic volcanic rocks, flysch-type sedimentary iron formations, graphitic mudrocks, and a large granodioritic to granitic batholith. Structurally, the Property is within the Casa Berardi Break, a 15km wide corridor of strain that can be traced over 200km. The Casa Berardi Fault, which strikes east-west and dips 80° to the south, was active during this stage along an unconformity between graphitic sedimentary and volcanic units.

Three principal styles of mineralization have been recognized at Casa Berardi with gold occurring in: 1) quartz veins, 2) stockworks, and 3) banded iron formation. The mineralized zones are closely associated with the Casa Berardi Fault and are found on both sides of the fault. They are restricted to a 500m wide corridor that is folded and plunges slightly to the west.

The grade of gold mineralization associated with veins generally increases with increasing complexity. Quartz phases include: 1) early grey quartz, with abundant sulfide and fluid inclusions; 2) mosaic micro-crystalline quartz associated with higher grades; and 3) late non-mineralized coarsely crystallized white quartz. Veins contain only 1% to 3% sulfides, predominately arsenopyrite and pyrite, as well as traces of sphalerite, chalcopyrite, pyrrhotite, tetrahedrite, galena, and gold. Arsenopyrite is the main gold-bearing sulfide present in all veins of the Casa Berardi deposit. Stockworks represent nearly the same volume as the large quartz veins. Stockwork mineralization is generally sub-economic, unless they occur in close proximity to larger quartz veins. Gold-bearing banded iron formation is restricted to the highly sheared, brecciated, and altered ferruginous sedimentary units occurring north of the Casa Berardi Fault. Mineralization contains up to 10% chert-magnetite beds, and exhibits high sulfide content which consists of pyrite, arsenopyrite, traces of pyrrhotite, and little or no visible gold.

The Casa Berardi deposit can be classified as an Archean-age, sedimentary-hosted lode-gold deposit. Gold deposits of the Archean Abitibi greenstone belt predominantly consist of epigenetic disseminated and vein-hosted deposits, and syngenetic gold-rich massive sulfides (Robert, et al., 2005; Monecke, et al., 2017). The Casa Berardi gold mining camp contains different styles of mineralization within the same deposit including gold-rich massive sulfides, auriferous pyritic and carbonaceous phyllite and chert, and pyrite-arsenopyrite-gold-quartz veins.

### 1.3.5 EXPLORATION

Since Hecla's acquisition of Casa Berardi in June 2013, exploration activities have largely consisted of staking and acquiring new claims, core drilling, geophysical surveys, drill-hole re-logging and drilling data compilation and integration. The majority of Hecla's exploration and delineation drilling since 2014 was core. No RC holes were drilled by Hecla, although there were 103 sonic holes drilled in 2022.

RESPEC believes that exploration potential remains on the Property along strike and at depth of known gold mineralization along the Casa Berardi Fault, both within and outside the current mine areas. Geophysical studies and drilling will be important exploration tools for making new discoveries at Casa Berardi, particularly for gold mineralization concealed by glacial till and other post-mineral overburden material outside the mine areas.

### 1.3.6 MINERAL RESOURCE ESTIMATES

Hecla considered density and quality of drill-hole data, the established continuity of the auriferous zones, and production experience in classification of the Casa Berardi gold Mineral Resources in the open pit and underground block models (Table 1-2). Classification was applied based on the average distance of a given block centroid to drill-hole composites used to estimate the block grade, the proximity to mine workings, and the location within modeled mineral envelopes. RESPEC considers Hecla's use of distances from composites and mine workings to be a reasonable approach to classifying resources. Average and closest distances of composites relative to blocks is commonly used in the mining industry for resource classification and satisfies S-K 1300 requirements.

**Table STYLEREF 1 \s 1-. Mineral Resource Estimate Summary – December 31, 2023**

11  
11

Resource Category	K Tonnes	Grade (g/t Au)	Contained Metal (k oz Au)
<b>Underground</b>			
Measured	997	7.30	234.0
Indicated	2,861	6.55	602.5
Measured and Indicated	3,858	6.74	836.6
Inferred	1,338	7.71	331.6
<b>Open Pit</b>			
Measured	61	0.96	1.9
Indicated	186	0.81	4.9
Measured and Indicated	247	0.85	6.7
Inferred	751	2.65	64.0
<b>Total</b>			
Measured and Indicated	4,106	6.39	843.3
Inferred	2,089	5.89	395.6

Notes:

1. In situ Mineral Resources are classified in accordance with the S-K 1300 classification system.
2. Mineral Resources were estimated by Hecla staff and reviewed and accepted by RESPEC.
3. Mineral Resources are exclusive of Mineral Reserves and do not have demonstrated economic viability.
4. Underground Mineral Resources are reported at cutoff grades ranging from 3.78g/t Au to 5.84g/t Au.
5. Open pit Mineral Resources are reported at cutoff grades ranging from 0.97g/t Au to 1.13g/t Au.
6. Underground and open pit Mineral Resources are reported using US\$1,750/oz Au, based on consensus, long-term forecasts from banks, financial institutions, and other sources, and a US\$/C\$ exchange rate of 1.300.
7. A minimum mining width of three meters was used for the modeled open pit and underground mineral envelopes used to estimate Mineral Resources.
8. Totals may not represent the sum of the parts due to rounding.

9. Mineral Resources potentially amenable to open pit mining methods are reported using a gold price of US\$1,750/oz, a throughput rate of 4,400 tonnes/day (combined material from underground and open pit sources), surface mining costs of US\$3.46/tonne mined, milling processing costs of US\$24.13/tonne processed, and general and administrative and other costs ranging from \$9.96-10.34/tonne processed. Metallurgical recoveries were based on metallurgical curves.
10. Mineral Resources potentially amenable to underground mining methods are reported using a gold price of US\$1,750/oz and a throughput rate of 4,400 tons/day (combined material from underground and open pit sources). Operating costs are US\$183.08/ton mined or US\$282.60/ton mined, depending on the underground zone or lens. Mill recoveries also vary by zone or lens and range from 80.10% to 89.90%.

All Mineral Resources reported in Table 1-2 used a gold price of US\$1,750/oz Au, which was chosen based on consensus, long-term forecasts from banks, financial institutions, and other sources, and a US\$/C\$ exchange rate of 1.300. The reported underground resources are undiluted and are exclusive of Mineral Reserves. The reported open pit resources are diluted by pit and are exclusive of Mineral Reserves. Mineral Resources that are not Mineral Reserves do not have demonstrated economic viability.

The underground Mineral Resources summarized in Table 1-2 are reported by tabulating all blocks within modeled mineral envelopes with estimated grades that exceed the calculated reporting cutoff grades, which vary for each zone or lens (sub-zone). The cutoff grades range from 3.78g/t Au to 5.84g/t Au, and are calculated based on a gold price of \$1,750/oz, and mill recoveries and operating costs that are specific to each zone. The resource estimates are based on a combined open pit and underground mill feed of 4,400tpd.

The reported open pit Mineral Resources in Table 1-2 are constrained by pit designs generated using cutoff grades that range from 0.97g/t Au to 1.13g/t Au. The gold cutoff grades were calculated at a gold price of \$1,750/oz, and using pit area-specific processing, general and administrative costs, recoveries, and refining costs. The mining cost is included in pit optimizations but is not included in the determination of the cutoff grade, as all material in each pit would be removed as either ore or waste.

RESPEC reviewed Hecla's Casa Berardi open pit and underground models, both visually and statistically. Gold grade and tonne smoothing during estimation is the primary issue in the models. Underground estimates are more tightly constrained by modeled mineral envelopes, so the smoothing is less pronounced compared to the open pit models. The grade smoothing increases risk associated with the Casa Berardi open pit resource models, which diminishes confidence in the local distributions of gold grades and tonnes within the broader wireframes. The homogenization of grade has resulted in models that likely overstate tonnes and understate grade, although the extent and the ultimate effects during mining cannot be fully quantified. However, the uncertainties associated with grade and tonne smoothing in the current models are offset in part by the history of productive mining at Casa Berardi.

### 1.3.7 MINERAL RESERVE ESTIMATES

Mineral Reserves have been classified in accordance with the definitions for Mineral Reserves in S-K 1300. Mineral Reserves as of December 31, 2023, are summarized in Table 1-3.

Measured Mineral Resources were converted to Proven Mineral Reserves, and Indicated Mineral Resources were converted to Probable Mineral Reserves. Inferred Mineral Resources were not converted to Mineral Reserves.

**Table 1-3. Summary of Mineral Reserves - December 31, 2023**

Reserve Category	Tonnes	Grade	Contained Metal	Metallurgical Recovery
------------------	--------	-------	-----------------	------------------------

13  
13

	(K t)	(g/t Au)	(K oz Au)	(%)
<b>Underground</b>				
Proven	50	4.14	6.7	-
Probable	159	5.06	25.9	-
Proven + Probable	209	4.84	32.6	88.7
<b>Open Pit</b>				
Proven	3,846	3.07	379.4	-
Probable	10,327	2.59	858.5	-
Proven + Probable	14,174	2.72	1,237.9	81.3
<b>Total</b>				
Proven + Probable	14,383	2.75	1,270.5	81.5

Notes:

1. Classification of Mineral Reserves is in accordance with the S-K 1300 classification system. Mineral Reserves are reported as in situ with the exception of mill stockpile volumes as defined in this report.
2. RESPEC is responsible for the statement of Proven and Probable Mineral Reserves.
3. Mineral Reserves are 100% attributable to Hecla.
4. Underground Mineral Reserves are estimated at a cutoff grade of 3.60g/t Au for 124 Zone and a 3.88g/t Au for the 118 and 123 Zones.
5. Open pit Mineral Reserves are estimated at a cutoff grade of 1.02g/t Au for the F160 pit and 1.18g/t Au for the WMCP, Principal, and F134 Pits.
6. Underground Mineral Reserves are estimated using short-term gold price of US\$1,850/oz Au and open pit Mineral Reserves are estimated using an average long term gold price of US\$1,650/oz Au, using a US\$/C\$ exchange rate of 1.300.
7. A minimum mining width of three meters was used for underground Mineral Reserves.
8. Totals may not represent the sum of the parts due to rounding.

Production for Casa Berardi over the current LOM, 2024 to 2037, includes 209kt from the underground operations in 2024 and 14.2Mt from the open pit operations from 2024 until 2037. Contained gold production over the LOM is forecasted to total 1.27Moz Au.

RESPEC is not aware of any risk factors associated with, or changes to, any aspects of the modifying factors such as mining, metallurgical, infrastructure, permitting, or other relevant factors that could materially affect the Mineral Reserve estimate.

### 1.3.8 MINING METHODS

The mine design and planning processes reflect the previous mining experience at the West and East mines. Currently, the entirety of the production comes from the West Mine which can be accessed by a shaft or a ramp down to the 1,080m level. The East Mine was barricaded off with a bulkhead in 2023 to allow for backfilling of the EMCP pit from the surface.

14  
14

A combination of longitudinal and transverse blasthole stoping is typically used at Casa Berardi, depending on mineral zone geometry (width and attitude) and development requirements. Timely delivery of backfill plays a crucial role in controlling dilution and maintaining the short stoping cycle. The zones vary in thickness, ranging from over 50m to less than three meters (e.g., minimum mining width). In general, the zones are subvertical (e.g., 55° to 85°).

Open pit mine designs and planning processes reflect previous experience with conventional truck shovel operations.

### 1.3.9 PROCESSING AND RECOVERY METHODS

The Casa Berardi processing facility consists of a 3,730tpd mill, with the ability to process 4,400tpd, and a CIL process to recover gold from the ore. The key unit operations to produce gold include:

- / Crushing
- / Grinding
- / Gravity Circuit
- / CIL Circuit
- / Electrowinning Circuit
- / Smelting

Residual pulp from the CIL mixing tank is pumped to the cyanide destruction tank to which sulfur dioxide and compressed air is added to destroy residual cyanide with agitation. After cyanide destruction, the treated pulp is then pumped to the paste backfill plant or the tailings pond. Ferric sulfate is also added to this material to reduce arsenic content in the solution. Approximately 5% of the Casa Berardi mine tailings are used in the mine backfill cycle. Tailings that are not used for mine backfill are disposed of at the tailings storage facility (TSF).

### 1.3.10 INFRASTRUCTURE

Existing surface and underground infrastructure at the East Mine include the following:

- / A nominal 3,730tpd mill, with the ability to process 4,400tpd.
- / F160, EMCP, and XMCP open pits.
- / TSF with five tailings cells, a polishing pond, a sedimentation pond for settling iron arsenate precipitates, and a process water pond.
- / Two-story administrative building with offices, warehouse, dry, laboratory, two heavy equipment maintenance garage, millwright shop, and electrical shop.
- / Two core shacks.
- / Water pumping station.
- / Hoistroom, a headframe, and a 380m deep shaft (with no hoist).
- / Mine access decline and a series of ramp-connected levels.
- / Three petrol tanks with pump gas and fuel.
- / One mineral stockpile.

15  
15

/ One waste and till-clay pile.

Existing surface and underground infrastructure at the West Mine include the following:

- / Backfill plant, including a compressor room and a ventilation raise intake.
- / Settling ponds.
- / Pumping station.
- / A 380 m<sup>2</sup> garage.
- / Two dry houses with offices.
- / Emergency building for mine rescue and infirmary.
- / Warehouse.
- / Core storage area.
- / Gatehouse.
- / Mine access decline providing access to the West Mine and Principal area.
- / Hoistroom, headframe, and mine shaft to the 1,080m level.
- / A 125 tonnes per hour (tph) paste backfill plant and a cement plant with tailings feed line from the mill and distribution holes to the underground.
- / Mine ventilation fans and mine air heater with ventilation raise to the mine workings.
- / One WRF and one ore rock pile.

There is currently no additional surface infrastructure related to the Principal Mine area. A five-kilometer track drift joins the East and West mines and provides access to the Principal Mine at the 280m level. After the East Mine was closed, a bulkhead was constructed on the track drift to control water flow to the West Mine.

The power supply of the site is provided by a 55km, 120kV power line, from the town of Normétal.

### 1.3.11 MARKET STUDIES

Hecla currently has a refining agreement with Asahi Refining Canada (Asahi) whereby the gold and silver is refined and credited to Hecla's account at Asahi. The doré bars produced at Casa Berardi are refined at Asahi's facilities in Brampton, Ontario, Canada.

Gold and silver bullion is sold through commercial banks or metal traders via a sale contract at spot prices. Settlement of funds from bullion sales occurs two business days after the contract date.

The terms and conditions of the refining and bullion sales contracts are typical and consistent with standard industry practice and would be similar to contracts for the supply of gold elsewhere in North America.

16  
16

### 1.3.12 ENVIRONMENTAL STUDIES, PERMITTING AND PLANS, NEGOTIATIONS, OR AGREEMENTS WITH LOCAL INDIVIDUALS OR GROUPS

Hecla has sufficiently assessed the environmental impact of the operation, and subsequent closure and remediation requirements such that Mineral Resources and Mineral Reserves can be declared, and the mine plan deemed appropriate and achievable. Closure provisions are appropriately considered, and monitoring programs are in place.

Hecla has developed a community relations plan to identify and ensure an understanding of the needs of the surrounding communities and to determine appropriate programs for addressing those needs. Hecla appropriately monitors socio-economic trends, community perceptions, and mining impacts.

Current permits held by Hecla for the Property are sufficient to ensure that planned surface and underground mining activities through 2026 are conducted within the regulatory framework required by regulations.

Beyond 2026, three additional open pits along with associated waste rock storage facilities and other infrastructure are expected to be developed at the Property. This planned development may require an Environmental Impact Assessment (EIA) at the site. Hecla expects to submit a project notice to the Provincial Ministère de l'Environnement, de la Lutte contre les changements climatiques, de la Faune et des Parcs (MELCCFP) in 2024. The notice is planned to include an overview of the proposed development and a description of the plan of operations. The EIA process typically takes several years to complete. Hecla expects that all necessary permits will be obtained, and that mining of the planned open pits can take place in accordance with local, provincial, and national regulatory frameworks.

There are currently no known environmental, permitting, or social/community risks that could impact the Mineral Resources or Mineral Reserves.

### 1.3.13 CAPITAL AND OPERATING COST ESTIMATES

The estimated capital costs for Casa Berardi are presented in Table 1-4. The majority of the growth capital is to be spent over the period 2028-2033.

**Table STYLEREF 1 \s 1-. LOM Capital Cost Summary**

<b>Description</b>	<b>Units</b>	<b>Total</b>	<b>2024-2027</b>	<b>2028-2033</b>	<b>2034-2037</b>
Growth Capital Costs USD\$	US\$(000)	421,455	83,368	338,087	-
Sustaining Capital USD\$	US\$(000)	76,972	38,937	27,490	10,545
Salvage Value	US\$(000)	(19,736)	-	-	(19,736)
Reclamation & Closure	US\$(000)	21,561	-	-	21,561
<b>Total Capital Costs USD\$</b>	<b>US\$(000)</b>	<b>500,253</b>	<b>122,305</b>	<b>365,577</b>	<b>12,371</b>

The capital costs are based on updates from equipment suppliers and verified with engineering companies providing services to Casa Berardi. The capital costs accuracy would be considered +/-15% with zero contingency. Major Projects include permitting costs for the LOM which include environmental, hydrogeological, and geotechnical studies, and condemnation drilling. Mine Stripping includes the overburden removal from WMCP and Principal pits. Open pit costs include mobilization of the open pit contractor and capitalized stripping costs. In year 2037 there is a salvage value of approximately US\$19.7 million for mine and other equipment that can be sold.

The estimated operating costs over the LOM (2024 to 2035) are presented in Table 1-5.

**Table STYLEREF 1 \s 1-. LOM Operating Cost Summary**

<b>Item</b>	<b>Total LOM</b>	<b>Total LOM</b>
	<b>(US\$000)</b>	<b>(US\$/t milled)</b>
Tonnes Milled (000 t)	14,383	
Mining	395,611	27.51
Processing	330,271	22.96
Administration	71,704	4.99
<b>Total</b>	<b>797,586</b>	<b>55.45</b>

Hecla-forecasted operating costs estimates are derived from annual budgets and historical actuals over the long life of the current operation. The operating costs accuracy would be considered +/-15% with zero contingency.

## 2.0 INTRODUCTION

RESPEC Company LLC (RESPEC) was retained by Hecla Mining Company (Hecla) of Coeur d'Alene, Idaho, USA, to prepare an independent Technical Report Summary (TRS) on the Casa Berardi Mine (Casa Berardi or the "Property"), located in Québec, Canada. The purpose of this TRS is to support the disclosure of the Casa Berardi Mineral Resource and Mineral Reserve estimates as of December 31, 2023. This TRS conforms to the United States Securities and Exchange Commission's (SEC) Modernized Property Disclosure Requirements for Mining Registrants as described in Subpart 229.1300 of Regulation S-K, Disclosure by Registrants Engaged in Mining Operations (S-K 1300) and Item 601 (b)(96) Technical Report Summary. There has been one previous TRS for Casa Berardi prepared by SLR Consulting (Canada) Ltd. (SLR) and dated February 21, 2022 (SLR, 2022). The current TRS herein draws extensively from SLR 2022 and supersedes the SLR 2022 TRS.

In this TRS, the term "RESPEC" refers to Qualified Persons (QPs) employed by RESPEC, as well as RESPEC employees working under the direct supervision of RESPEC QPs.

The Casa Berardi operation includes several open pits and two underground mines. Collectively, these workings produced approximately 3.06 million ounces (Moz) Au (recovered) since commencing production in 1988, including approximately 2.37Moz Au (recovered) since production recommenced in November 2006.

The Casa Berardi processing facilities consist of a mill, with the ability to process 4,100tpd, and a carbon-in-leach (CIL) process to recover gold from the ore.

Production for Casa Berardi over the current life of mine (LOM), 2024 to 2037, is planned to comprise 209 thousand tonnes (kt) from the underground operations in 2024 and 14.2 million tonnes (Mt) from the open pit operations from 2024 until 2037. Gold production over the LOM is forecasted to total 1.04Moz Au (average of 86,000oz Au per annum) while recovered silver is forecasted to total 249,000oz Ag (average of 20,700oz Ag per annum).

### 2.1 SITE VISIT

RESPEC visited Casa Berardi September 18-22, 2023. The initial F160 Pit Phase was nearing completion while RESPEC was at site, and underground mining operations were expected to cease within a year. RESPEC held meetings with site personnel and followed up with several teleconference meetings after the site visit.

RESPEC engineering QPs visited the F160, East Mine Crown Pilar (EMCP), western extension (XMCP) Pit, the West Mine underground, tailings storage facilities (TSF), core logging facilities, and surface infrastructure.

The geology of the gold mineralization was observed underground in the Principal and West deposits, in the F160 and EMCP open pits, and in core from various areas by RESPEC's geology QP. An underground diamond drill in the process of drilling core hole CBW-1223 was also visited. Core processing and sample handling procedures were reviewed in the core shack, and Hecla provided a tour of the mine laboratory. Resource modeling and estimation procedures were discussed in detail with Hecla Québec's Principal Geologist, Real Parent.

19  
19

## 2.2 SOURCES OF INFORMATION

Most of the information in this TRS has been drawn from Hecla company files and other sources as cited. Section 10.0 Mineral Processing and Metallurgical Testing, and Section 14.0 Processing and Recovery Methods were contributed by SLR.

During the preparation of this TRS, discussions were held with Hecla personnel to obtain information and data contained in the technical report summary or used in its preparation.

The documentation reviewed, and other sources of information as cited, are listed in Section 24.0 References.

## 2.3 UNITS AND ABBREVIATIONS

Units of measurement used in this TRS conform to the metric system.

Currency, units of measure, and conversion factors used in this report include:

### Linear Measure

1 centimeter	= 0.3937 inch	
1 meter	= 3.2808 feet	= 1.0936 yard
1 kilometer	= 0.6214 mile	

### Area Measure

1 hectare	= 2.471 acres	= 0.0039 square mile
-----------	---------------	----------------------

### Capacity Measure (liquid)

1 liter	= 0.2642 US gallons
---------	---------------------

### Weight

1 tonne	= 1.1023 short tons	= 2,205 pounds
1 gram	= 0.03215 troy ounces	
1 kilogram	= 2.205 pounds	

### Grade

1 gram/tonne	= 0.0292 troy ounces/short ton
--------------	--------------------------------

Currency in this TRS is in United States dollars (US\$) unless otherwise noted. Canadian dollars (C\$) have been converted to US\$ dollars at an exchange rate of US\$1 = C\$1.300 unless otherwise noted.

Abbreviation	Unit	Abbreviation	Unit
m	Micron	kVA	kilovolt-amperes
mg	Microgram	kW	kilowatt
a	Annum	kWh	kilowatt-hour
A	Ampere	L	liter
Ac	Acre		

20  
20

Abbreviation	Unit	Abbreviation	Unit
AMSL	Above Mean Sea Level		
bbbl	Barrels	lb	pound
Btu	British thermal units	L/s	liter per second
°C	degree Celsius	m	meter
C\$	Canadian dollars	M	mega (million); molar
cal	Calorie	m <sup>2</sup>	square meter
cfm	cubic feet per minute	m <sup>3</sup>	cubic meter
cm	Centimeter	m <sup>3</sup> /h	cubic meters per hour
cm <sup>2</sup>	square centimeter	mi	mile
d	Day	min	minute
dia	Diameter	mm	micrometer
dmt	dry metric tonne	mm	millimeter
dwt	dead-weight ton	mph	miles per hour
°F	degree Fahrenheit	MVA	megavolt-amperes
ft	Foot	MW	megawatt
ft <sup>2</sup>	square foot	MWh	megawatt-hour
ft <sup>3</sup>	cubic foot	oz	Troy ounce (31.1035g)
ft/s	foot per second	oz/st, opt	ounce per short ton
g	Gram	ppb	part per billion
G	giga (billion)	ppm	part per million
Gal	Imperial gallon	psia	pound per square inch absolute
g/L	gram per liter	psig	pound per square inch gauge
Gpm	Imperial gallons per minute	RL	relative elevation
g/t	gram per tonne	s	second
gr/ft <sup>3</sup>	grain per cubic foot	st	short ton
gr/m <sup>3</sup>	grain per cubic meter	stpa	short ton per year
ha	Hectare	stpd	short ton per day
hp	Horsepower	t	metric tonne
hr	Hour	tpa	metric tonne per year
Hz	Hertz	tpd	metric tonne per day
in	Inch	US\$	United States dollar
in <sup>2</sup>	square inch	USg	United States gallon
J	Joule	USgpm	US gallon per minute

Abbreviation	Unit	Abbreviation	Unit
k	kilo (thousand)	V	volt
kcal	Kilocalorie	W	watt
kg	Kilogram	wmt	wet metric tonne
km	Kilometer	wt%	weight percent
km <sup>2</sup>	square kilometer	yd <sup>3</sup>	cubic yard
km/h	kilometer per hour	yr	year
kPa	Kilopascal		

# 3.0 PROPERTY DESCRIPTION

## 3.1 LOCATION

The Property is located in the Province of Québec, approximately 95km north of the town of La Sarre, in the James Bay Municipality (Figure 3-1). The mine is located at longitude 79° 16' 46.4" and latitude 49°33'56.7". The Property is bounded in the west by the Québec/Ontario border and covers parts of Casa Berardi, Dieppe, Raymond, D'Estrées, and Puiseaux townships.

The Property extends east to west for more than 37km and is up to 3.5km wide in a north to south direction (Figure 3-2.). The immediate mine area comprises three mining leases covering an area of 574 hectares. The gold deposits are located along an east-west trending mineralized corridor and are included within the East and West mine areas (Figure 3-2.; Figure 3-3).

**Figure STYLEREF 1 \s 3-. Project Regional Location Map**  
(from Hecla, 2023; yellow area is the Property)

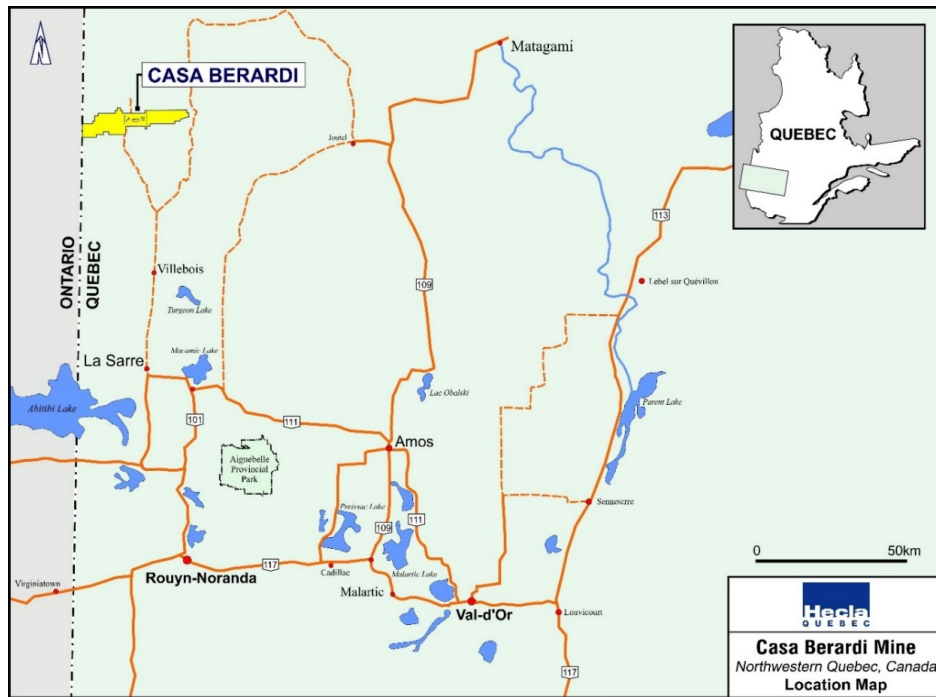

Figure STYLEREF 1 \s 3-. Property Location Map  
 (from Hecla, 2023)

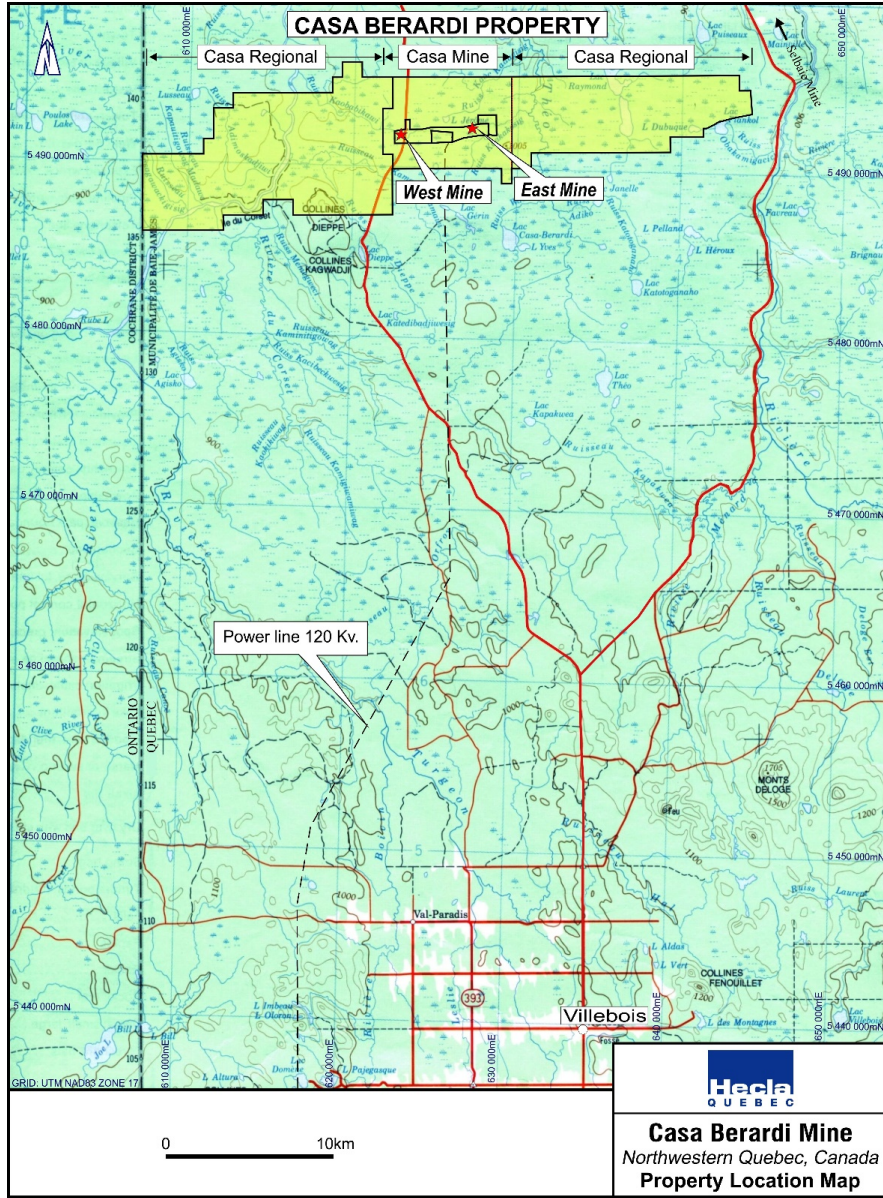
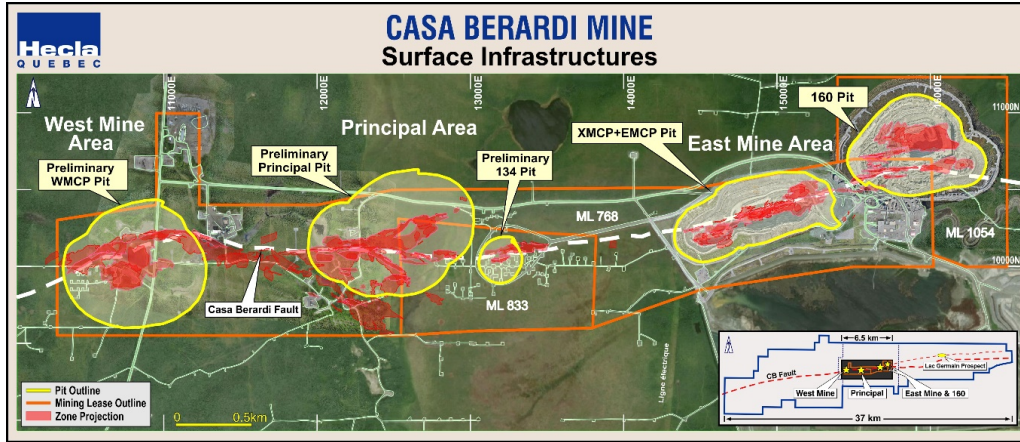

Figure STYLEREF 1 \s 3-. Plan View of Current and Planned Infrastructure  
(from Hecla, 2023)



## 3.2 LAND TENURE

RESPEC is not an expert on land and mineral tenure, legal matters pertaining to land and mineral tenure or rights to such tenure. RESPEC has therefore fully relied on Mr. Keith Blair, Chief Geologist, Hecla, and Mr. Patrice Simard, Geology Superintendent, Hecla Québec, for the information disclosed in this section of the TRS.

The Property consists of 391 contiguous designated claims, covering a total area of 19,150 hectares, and three mining leases, BM 768, BM 833, and BM 1054 covering areas of 397 hectares, 84 hectares, and 93 hectares, respectively (Figure 3-4). The Property area totals 19,725 hectares. Other legal titles include non-exclusive leases BNE 25938, tailings lease 70218, and two waste rock facility (WRF) leases 192410 and 819410. Legal titles are under the name of Hecla Québec.

In September 1998, Aurizon completed the acquisition of all Casa Berardi assets and mining rights for the Property. Hecla acquired Aurizon in June 2013 and the company was renamed Hecla Québec, a wholly owned subsidiary of Hecla. By 2012, Lake Shore Gold Inc. (Lake Shore) earned into a 50% interest in certain claims and mineral rights within the Casa Berardi Exploration Property (Casa Exploration Property), but not in areas where production was occurring, pursuant to a 2007 option agreement between the parties. In February 2016, Tahoe Resources Inc. (Tahoe) purchased Lake Shore, and at the end of 2016, they opted to sell their 50% interest in the Casa Exploration Property to Hecla in exchange for C\$6 million (US\$ 4,433,400 million) and 1% NSR on 227 claims. Hecla repurchased the related 1% NSR in June 2021. From June 1, 2013 to December 31, 2021, production from Casa Berardi totaled approximately 9.0Mt at an average grade of 4.88g/t Au for a total of 1.17Moz Au recovered.

According to the Québec Mining Act, renewal of claims takes place every two years, with costs dependent on area. Mining leases are renewed annually. The Casa Berardi claims and mining leases will be renewed for amounts of

25  
25

US\$41,633.25 (C\$55,861.06), in accordance with the 2024 rates set by the government. The Casa Berardi claims are in good standing. The renewal costs are adjusted to the annual inflation rate.

The Québec Mining Act stipulates that a titleholder is required to conduct statutory work during the validity period of the claim. Each claim or lease shows excess spending amounts for required works. These amounts are put to the credit of the claims and are expected to cover several years in most cases. The Property has excess work credits of approximately US\$15,480,559.52 (C\$20,770,910.40).

The school taxes to the James Bay School Board and the Lac-Abitibi School Board have been paid for 2023.

The municipal taxes to the James Bay, Villebois, Dupuy, and La Sarre municipalities have been paid for 2023.

26  
26

RSI-M0206.22001

---

Figure STYLEREF 1 \s 3-. Property Claim Map

(from Hecla, 2023, central un-patterned area shows mining leases covering the East, Central and West mining areas)

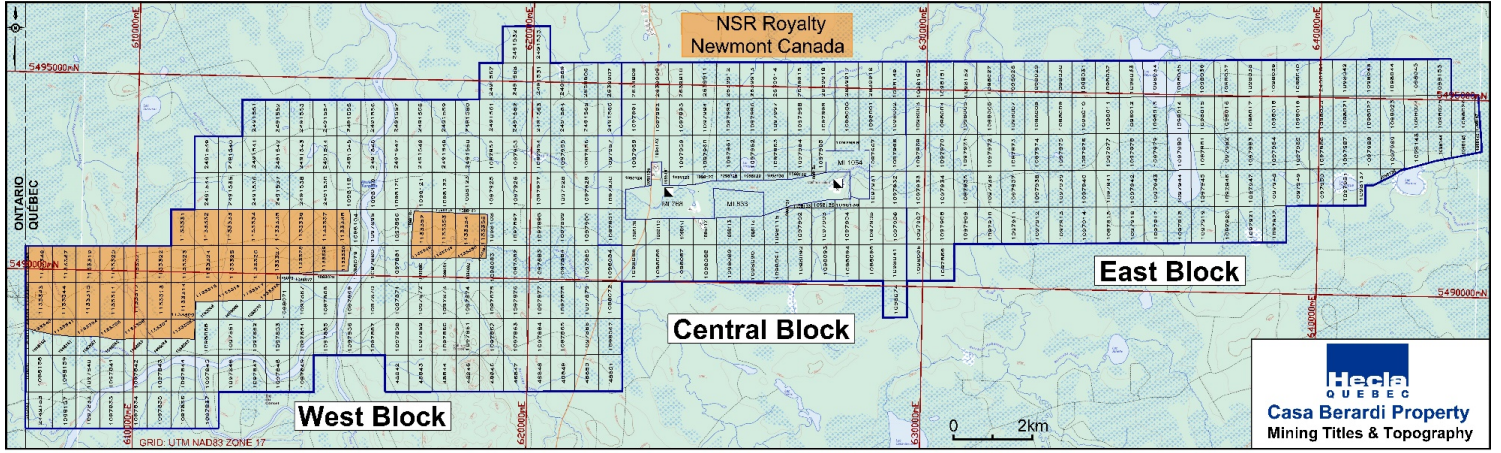

### 3.3 ENCUMBRANCES

Hecla has all the required permits to conduct the current mining operations on the Property. The Property will be undergoing an Environmental Impact Assessment (EIA) for planned development and mining beyond 2026. There are no significant encumbrances to the Property nor any violations or fines.

### 3.4 ROYALTIES

The Casa Berardi landholdings within the three mining leases are not subject to any royalty and Hecla, through its wholly owned subsidiary, Hecla Québec, holds a 100% interest in the Casa Berardi property. Most of the Casa Berardi Mineral Reserves and Resources and the processing plant are located inside the mining leases Figure 3-4. The Casa Berardi property outside the mining leases is completely owned by Hecla Québec. There is a sliding net smelter return (NSR) royalty (currently 3.0%) held by Newmont Canada Corp. on 52 claims within the land tenure (Figure 3-4).

### 3.5 OTHER SIGNIFICANT FACTORS AND RISKS

The authors are not aware of any significant factors and risks that may affect access, title, or the right or ability to perform the proposed work program on the Property, other than those discussed in this report.

- / The appropriate environmental permits have been granted for the current operation.
- / Hecla does not have permits for facilities labeled as “Preliminary”. The locations, size, and timing of facilities labeled as “Preliminary” have not been finalized and are subject to future long-term mine plans.
- / As of the effective date of this TRS, environmental liabilities are limited to those that would be expected to be associated with an operating gold mine where production occurs from underground and open pit sources, including roads, site infrastructure, and WRFs.
- / Hecla is not aware of any significant environmental, social, or permitting issues that would prevent continued exploitation of the Casa Berardi deposits.
- / Information provided by Hecla land tenure experts supports that the mining tenure held is valid and is sufficient to support the declaration of Mineral Resources and Mineral Reserves, subject to those issues discussed in Section 25.0.
- / Hecla holds sufficient surface rights in the Project area to support the mining operations, including access and power line easements.

## 4.0 ACCESSIBILITY, CLIMATE, LOCAL RESOURCES, INFRASTRUCTURE AND PHYSIOGRAPHY

### 4.1 TOPOGRAPHY, ELEVATION AND VEGETATION

The topography at the Casa Berardi property is gentle with elevations ranging from 270m and 360m above mean sea level (AMSL). The terrain is characterized by swamps and alluvial coverage which is locally up to 60m deep. The region falls within the boreal zone and the spruce and moss domain. Forested areas of the Property are predominately characterized by jack pine and spruce but have generally been logged out. The active mine area is characterized by swamps and is classified as a bare to semi-bare wetland. The Turgeon River extends across the western portion of the Property and Lac Jérôme is in the north central portion of the Property.

### 4.2 CLIMATE

The data used in this section is from Hecla (2014) and is based on a weather station located near the Property. The mean annual temperature for the Property area is -5°C, with an average high in July of 17°C, and an average low in January of -18°C.

The average annual precipitation in the Property area is about 91cm. Rain precipitation is greatest in July and August, averaging 10.5cm per month. While snow precipitation can occur from October to April, most falls in February and March when the monthly average can reach more than one meter (10.7cm expressed in centimeters of water content). Exploration and mine operations can take place year-round.

### 4.3 ACCESS

The Property is located 95km north of the town of La Sarre in the Abitibi region of northwestern Québec. The nearest commercial airport is located at Rouyn-Noranda which is approximately 175km south of the Property. La Sarre can be reached from Rouyn-Noranda via provincial roads 101 and 111. A 39-kilometer all season gravel road to the Property diverges from the paved road linking La Sarre and the Selbaie Mine through the village of Villebois. The exit is approximately 21km north of Villebois.

### 4.4 LOCAL RESOURCES

The Abitibi region has a long history of mining activity, and mining suppliers and contractors are locally available. Both experienced and general labor is readily available from the La Sarre area, a municipality of about 7,400 inhabitants (2021 census). Hecla has had success in hiring experienced staff and personnel with good mining expertise. Casa Berardi generally has the support of local communities.

29  
29

## 4.5 INFRASTRUCTURE

The active mining portion of the Casa Berardi Property is in the central part of the overall land package (Figure 3-2). This portion of the property is divided into the East and West mine areas which include most of the surface infrastructure, open pits, and underground mines (Figure 4-1). A gravel road connects the East and West mine areas and production and staff roads. Roads will be adjusted as required during the life of the mine. Exploration roads provide access to the rest of the Property. A detailed discussion of onsite infrastructure and planned infrastructure is presented in Section 15.0 of this TRS.

Power supply for the entire Property is provided by a 55km-long, 120kV power line, from the town of Normétal.

There is sufficient suitable land available within the mineral tenure held by Hecla for tailings disposal, mine waste disposal, and installations such as the process plant and related mine infrastructure.

A review of the existing power and water sources, personnel availability, and transport options by Hecla indicates that there are reasonable expectations that sufficient labor and infrastructure will continue to be available to support the extraction of the estimated Mineral Resources, Mineral Reserves, and to execute the proposed LOM plan.

Figure STYLEREF 1 \s 4-. Surface Infrastructure

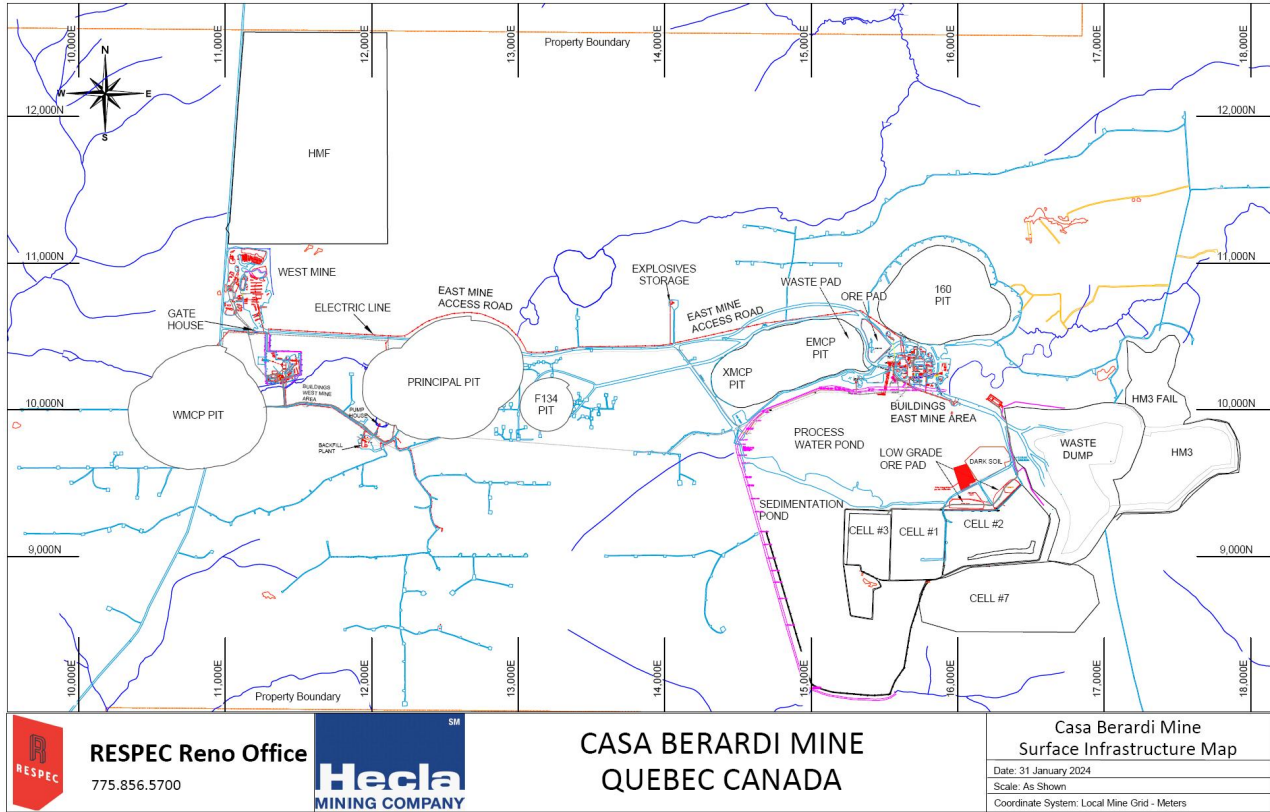

# 5.0 HISTORY

## 5.1 EXPLORATION AND DEVELOPMENT HISTORY

### 5.1.1 1974 TO 1996

Prior to 1974, the Casa Berardi area was explored for base metal deposits. In 1974, the first 13 claims were staked by Inco Gold Ltd. (Inco Gold). The discovery hole was drilled in 1981, and 590 additional claims were staked. In 1983, a joint venture (JV) agreement was reached between Inco Gold (60%) and Golden Knight Resources Inc. (Golden Knight) (40%). The subsequent years were marked by exploration drilling and, eventually, project engineering and construction. Under the Inco Gold-Golden Knight JV, commercial gold production from the East and West mines began in 1988 and 1990, respectively.

In 1991, TVX Gold (TVX) acquired Inco Gold's 60% interest in the Property. In 1994, TVX and Golden Knight purchased the remaining interest in the Domex claim block, a part of the Principal (Main) Zone between the West and the East Mine, from Teck Corporation.

By 1996, 4,777 holes had been drilled on the Property for a total of 649,737.45 meters. Approximately 92% of these holes were located in the area between the West and East mines.

The first mineral reserve estimate for Casa Berardi was published in 1987. Production began at the East Mine in September 1988 and at the West Mine in April 1990. In January 1997, TVX announced the closure of the East Mine due to ground control issues. Two months later, the West Mine was also closed.

### 5.1.2 AURIZON (1997 TO 2013)

Casa Berardi was offered for sale in the fall of 1996, and in January of 1997 Aurizon signed an agreement and completed the acquisition of all Casa Berardi assets and mining rights. Following the acquisition of Casa Berardi, Aurizon conducted exploration core drilling of more than 170,189m (141,541m from surface and 28,648m from underground). The primary objective of the campaign was to increase the gold mineral inventory of the Property by drilling prospective sectors below the 400m level in the West Mine area. The program resulted in the discovery of the 113 Zone and other smaller mineralized bodies.

Using the results of this drilling as a basis for Mineral Resource estimation, Aurizon issued an internal study in March 2000, which provided positive indications of the economic potential of the West Mine area below the 400m level. Following two years of limited exploration drilling activities due to depressed gold prices, Aurizon re-embarked on a surface exploration program that led to the discovery of additional zones east of the 113 Zone.

To increase the confidence level of the Mineral Resources and prove the potential of a mining operation, an underground exploration program was initiated in April 2003 to test the continuity of the 113 Zone mineralization. In 2003, the West Mine ramp was also extended 1,074m from the 450m level to the 550m level, to provide access to the 113 Zone for metallurgical test work and to provide drill bases for infill definition drilling. Approximately 40m of the exploration drift was completed by the year-end, allowing for the completion of 1,402m of definition core drilling. A further 21,000m of surface drilling was completed in the 118 through 120 zones during 2003.

In 2004, US\$ 21.6 million (C\$27.6 M) was invested for the construction of the surface foundations and shaft collar, a shaft pilot raise from the 550m level to surface, 878m of exploration drifts, 64,724m of exploration and definition drilling, 102m of ventilation raising, and 1,591m of ramping down to the 550m level. Met-Chem Canada Inc. (Met-Chem) was commissioned to prepare a feasibility study. Aurizon proceeded with the implementation and construction of the West Mine infrastructure.

In 2005, US\$ 34.4 million (C\$43.8 million) was invested in Casa Berardi for:

- / Completion of two feasibility studies (the Feasibility Study by Met-Chem in January 2005, based upon Mineral Reserves above the 700m level, and the Updated Feasibility Study in October 2005, incorporating Mineral Reserves to the 900m level.
- / Construction of a new headframe, hoistroom, and ore and waste bins.
- / Shaft sinking 289.6m from surface.
- / 113 Zone ramp extension 1,063.8m down to the 680m level.
- / Access to the Lower Inter Zone down to the 570m level with the completion of 429.8m of ramping and drifting.
- / 685.8m of drifting and 365.8m of ventilation raising.
- / Initiation of mill rehabilitation with the refurbishing of the crushing circuits, conveyors, and assay laboratory.
- / 32,947m of underground definition drilling from 135 holes, 26,068m of surface core drilling from 68 holes, and detailed engineering for the shaft and surface infrastructure.

In 2006, an additional US\$59.2 million (C\$75.5 million) was invested to fund construction and development. In early November 2006, Aurizon completed construction and development at the West Mine area and commenced underground mining and milling operations.

In 2007, US\$13.3 million (C\$16.9 million) was invested to fund pre-production up to May 1, 2007, the date of achieving commercial production. From 2008 to 2013, a total of US\$232.9 million (C\$297 million) was invested in fund development, infrastructure improvements, new equipment, and exploration expenses.

In September 1998, Aurizon completed the acquisition of all Casa Berardi assets and mining rights for the Property. Hecla acquired Aurizon in June 2013 and the company was renamed Hecla Québec, a wholly-owned subsidiary of Hecla. By 2012, Lake Shore Gold Inc. (Lake Shore) earned into a 50% interest in certain claims and mineral rights within the Casa Berardi Exploration Property (Casa Exploration Property), but not in areas where production was occurring, pursuant to a 2007 option agreement between the parties. In February 2016, Tahoe Resources Inc. (Tahoe) purchased Lake Shore, and at the end of 2016, they opted to sell their 50% interest in the Casa Exploration Property to Hecla in exchange for C\$6 million (US\$ 4,433,400 million) and 1% NSR on 227 claims. Hecla repurchased the related 1% NSR in June 2021.

## 5.2 HISTORICAL DRILLING - 1957 TO 2013

Table 5-1 summarizes all known drilling carried out by Aurizon and Lake Shore from 1997 through 2013, and previous operators from 1957 through 1996. All holes are core, or presumed to be core, unless otherwise specified in the table. No information is available for drilling done prior to Aurizon, and for Aurizon prior to 2006. Aurizon conducted exploration and development drilling in and around the Casa Berardi Mine areas. Lake Shore drilled from

33  
33

2008 to 2012 under an agreement with Aurizon and focused on the Casa Berardi Property outside the Casa Berardi Mine.

**Table STYLEREF 1 \s 5-. Historical Drilling 1957 through 2013**

Company	Year	Surface		Underground		Total	
		Holes	Meters	Holes	Meters	Holes	Meters
Inco Gold, Golden Knight, TVX	1957-1996 Core	252	354,985.25	2,135	221,716.74	2,387	576,701.99
	1957-1996 RC	2390	73,035.46			2,390	73,035.46
Aurizon	1997 to 2003	295	141,541.22	202	28,647.65	497	170,188.87
	2004	50	26,676.75	243	38,046.80	293	64,723.55
	2005	68	26,068.45	135	32,947.05	203	59,015.50
	2006	118	51,763.56	428	51,203.70	546	102,967.26
	2007	31	19,331.70	273	20,520.80	304	39,852.50
	2008	46	16,691.82	293	26,075.60	339	42,767.42
	2009	68	28,428.91	484	57,806.40	552	86,235.31
	2010	102	47,368.74	425	71,143.40	527	118,512.14
	2011	133	44,294.61	418	70,674.50	551	114,969.11
	2012	73	34,046.31	560	71,186.30	633	105,232.61
	2013	68	20,744.90	566	48,537.00	634	69,281.90
Total Aurizon		1,052	456,956.97	4,027	516,789.20	5,079	973,746.17
Lake Shore	2008 Core	12	4,470.12			12	4,470.12
(External to Mine Area)	2008 RC	79	1,907.90			79	1,907.90
	2009	16	7,219.14			16	7,219.14
	2010	11	4,111.00			11	4,111.00
	2012	1	699.00			1	699.00
Total Lake Shore		119	18,407.16			119	18,407.16
Unknown	Unknown	1200	41,176.17	1	30.00	1,201	41,206.17
Total Historical Drilling		4,761	589,575.76	4,028	516,819.20	8,789	1,106,394.96

### 5.2.1 HISTORICAL DRILLING – AURIZON, 2006 TO 2013

Aurizon conducted various exploration and delineation drilling programs in and around the Casa Berardi Mine from 2006 to 2013. Nothing is known regarding the drilling and sampling procedures followed during this period, other than that the drilling was conducted using wireline core and reverse-circulation (RC) methods. Apparently, Hecla has not determined and compiled the core diameters used based on review of historical drill logs and inspection and re-sampling of historical drill samples. RESPEC recommends that Hecla compile such information if it is available. Unless stated otherwise, all historical drilling summarized in this section of the TRS was conducted with wireline core methods.

In 2006, definition drilling was done in the 113 and the Lower Inter zones. Exploration drilling was carried out to follow up on Inferred Mineral Resources in the 118 to 120 zones that were identified by wide-spaced drilling from surface. The extension of mineralization contained in the EMCP was also tested. Exploration of the 122 Deep Zone continued where underground exploration intersected high grade mineralization along the Casa Berardi Fault, 1,000m below surface and 800m from the existing infrastructure.

In 2007, definition drilling continued in the 113 Zone. The first phase of definition drilling in the Lower Inter Zone was completed. Underground exploration drilling was focused in the 118 to 120 zones.

Surface exploration drilling targeted the 123 Zone, the most significant discovery of mineralization to date outside the Casa Berardi Fault. The 123 Zone is located 350m south and 900m east of the existing West Mine infrastructure.

In 2008, surface drilling was conducted at the East Mine to convert Inferred Mineral Resources to Indicated Mineral Resources. Definition and infill drilling programs were conducted in the 113 and Principal area zones.

In 2009, surface drilling was mainly concentrated in the Principal area to increase Mineral Resources and to evaluate open pit and underground potential. Underground drilling was carried out in the 118 and 123 zones from the 810m level exploration drift. Definition and infill drilling were primarily carried out in the 113, 118, 123, and Lower Inter zones.

In 2010, surface drilling was predominately concentrated in the Principal area of the West Mine to convert Mineral Resources into Mineral Reserves. Underground drilling was carried out in the 118 and 123 zones from the 810m level exploration drift. Definition and infill drilling were primarily carried out in the Lower Inter, 109, 113, 115, 118, 123, and 124 zones.

In 2011, the surface drilling tested down-plunge of the Lower Inter Zone, the northeast extension of the 118, 123 and 124 zones, deep down-plunge of the 123 Zone, the potential at depth of the East Mine, and the open pit potential of the 160 Zone. Underground drilling was carried out to verify continuity and extensions of the Principal Mine, primarily in the 118 Zone. Definition and infill drilling were conducted in the 109, 118, 119, 123, and 146 zones.

In 2012, the surface drilling program was carried out to test the western extension of the 160 Zone, the eastern extension of the Principal area in the West Mine, and the potential at depth of the Lower Inter, 123 zones, and the East Mine. Underground exploration drilling was conducted to verify continuity and extensions of the Lower Inter, Principal Mine, 118, 140, and 160 zones.

Hecla commenced acquisition of the Casa Berardi project in 2013. Drilling by Aurizon was ongoing at the time. The combined discussion of drilling target areas for both companies during the entire year are discussed here, and not repeated in Section 7.0

Surface drilling tested the extensions of the 123 and 134 zones. Underground drilling was primarily carried out in the 140 and 159 zones, while definition and infill drilling were mainly carried out in the 113, 115, 118, 119, 123 zones.

### 5.2.2 HISTORICAL DRILLING LAKE SHORE, 2007 TO 2012

Lake Shore focused their exploration drilling on the Casa Berardi Property outside the Casa Berardi Mine, primarily in the Lac Germain prospect and in the West Block area.

#### 5.2.3 2008

In the winter of 2008, an initial drilling program comprising 12 holes, totaling 4,470m, was carried out. Ten holes were drilled approximately 7.5km east of the East Mine and Mill Complex, in an area now known as the Lac Germain prospect. Two holes, CE-08-06 and CE-08-09, were drilled near Inco Gold's hole 84716-0, two kilometers to the west of this area. In addition, 79 RC holes were completed in the East Block.

The winter 2008 diamond drilling program succeeded in the discovery of the G Zone at the Lac Germain prospect. The best intersection in hole CE-08-03 yielded 13.03g/t Au over 6.45m within a broader interval of 8.58g/t Au over 10.4m. This mineralization was located approximately 90m below a historical value of 11.11g/t Au over 2.24m in Inco Gold's hole 84724-0. The G Zone was then subdivided into three sub-zones referred to as the G-S Zone, G-Mid Zone, and G-N Zone. Gold mineralization was associated with quartz-carbonate-sulfide veins within sedimentary rocks, north of a mafic volcanic package. Higher-grade mineralization displayed stronger wall rock alteration and a higher sulfide content, with some quartz and sulfide stringers at a shallow angle to the core axis.

The 79-hole RC drill program was designed to test new areas and to follow up on areas of interest identified during the compilation of previous data, including two dispersal trains in glacial till east of the Theo River area. A total of 173 bedrock samples were collected during the RC program and assayed for gold. The sources of the two gold dispersal trains were interpreted to be near the northern contact between mafic volcanic and sedimentary rocks. The first dispersal train was located south of Lake Shore's drill holes CE-08-06 and CE-08-09. The second gold dispersal train occurred approximately 4.1km east of Lac Germain and 5.1km east of the Lac Germain prospect.

#### 5.2.4 2009

In 2009, Lake Shore drilled 16 holes totaling 7,219m in the Property. Ten of the 16 holes, totaling 3,979m, were drilled on the Lac Germain prospect while the remaining six, totaling 3,240m, were drilled in the West Block between the West Mine and the former Agnico Eagle claim block. The drilling at the Lac Germain prospect extended the G Zone. Hole CE-09-12, to the east, returned 2.33g/t Au over 7.3m, and hole CE-09-18, to the west, returned 3.04g/t Au over 6.3m. Drilling in the West Block led to the discovery of a new gold zone in hole CW-09-23 that returned 3.44g/t Au over 3.9m in a broader 23.2m gold anomalous interval. Mineralization consisted of ribboned, quartz-ankerite veins with 5% to 70% pyrite and pyrrhotite and minor arsenopyrite, within a large package of chert-sulfide iron formation in strongly deformed and altered graphitic wacke.

36  
36

### 5.2.5 2010

In 2010, Lake Shore drilled 11 holes totaling 4,111m. Eight holes totaling 2,814m, were drilled in the Lac Germain prospect, while the remaining three targeted aeromagnetic anomalies similar to the one at the Lac Germain prospect. New drilling results on the G Zone included 11.54g/t Au over 3.9m in CE-10-30 and 4.75g/t Au over one meter in hole CE-10-32, both located in the west-central portion of the G Zone. On the eastern end of the G Zone, holes CE-10-29 and CE-10-31 returned several anomalous and high-grade gold intervals, notably 40.2g/t Au over 0.4m and 8.4g/t Au over 1.4m in hole CE-10-29, and 14.7g/t Au over 0.5m in hole CE-10-31.

Hole CE-10-35, which tested a magnetic anomaly to the east of Lac Germain approximately five kilometers east of the Lac Germain prospect, did not intersect gold mineralization. Holes CE-10-36 and CE-10-37 were drilled to test magnetic anomalies at the west end of the East Block. Only one interval in hole CE-10-36 yielded 1.63g/t Au over one meter. Hole CE-10-37 intersected a narrow quartz vein with one speck of visible gold that yielded no significant assay, and another quartz vein which returned 2.57g/t Au over 0.8m.

### 5.2.6 2012

During the summer of 2012, Lake Shore drilled hole CW-12-38 to test the down-dip extension of the gold mineralization intersected in hole CW-09-23. Hole CW-12-38 intersected some gold bearing mineralization including intervals of 3.24g/t Au over 1.5m, and 1.38g/t Au over 12.4m within which was a 3.1m interval grading 2.53g/t Au.

## 5.3 HISTORICAL PRODUCTION

Inco Gold's and TVX's total combined production for the period from 1988 to 1997 was 3.5Mt at an average grade of 6.1g/t Au totaling over 688,400oz of gold recovered, with an average mill gold recovery rate of 87%. Annual production during this period is summarized in Table 5-2.

Table 5-2. Historical Mine Production 1988 – 1997

Year	Tonnes Milled (t)	Grade (g/t Au)	Mill Recovery (%)	Gold Recovered (oz Au)
1988	124,057	5.9	88.0	19,025
1989	337,130	5.5	86.4	51,096
1990	361,935	8.9	87.4	88,999
1991	487,769	8.7	86.9	119,015
1992	315,938	9.3	87.1	80,319
1993	306,597	10.0	89.3	86,964
1994	550,638	6.5	86.8	97,518
1995	469,542	4.7	85.7	61,179
1996	498,405	5.4	87.2	76,039
1997	51,356	5.8	87.2	8,270
Total	3,503,367	6.1	87.0	688,424

From 2006 through May of 2013, a total of 4.31Mt at an average grade of 7.08g/t Au were milled by Aurizon at Casa Berardi for a total of 0.98Moz recovered gold and an average gold recovery of 91.6% Table 5-3.

**Table STYLEREF 1 vs 5-. Casa Berardi Production 2006 to mid-2013**

<b>Company</b>	<b>Year</b>	<b>Tonnes Milled (t)</b>	<b>Grade (g/t Au)</b>	<b>Contained Metal (oz Au)</b>	<b>Gold Recovered (oz Au)</b>	<b>Gold Mill Recovery (%)</b>
Aurizon	2006	68,481	8.58	18,891	17,731	93.9
	2007	545,259	9.78	171,416	159,469	93.0
	2008	654,398	8.16	171,628	158,830	92.5
	2009	688,677	7.77	172,013	159,261	92.6
	2010	722,746	6.76	157,134	141,116	89.8
	2011	698,123	8.00	179,462	163,845	91.3
	2012	693,859	6.77	151,059	136,848	90.6
	May-13	238,931	6.17	47,394	43,447	91.7
Total 2006 - mid-2013	4,310,474	7.08	1,068,997	980,547	91.6	

## 6.0 GEOLOGICAL SETTING, MINERALIZATION, AND DEPOSIT

This section of the TRS has been extracted and modified from SLR 2022, which was drawn from Clow et al. (2005). The text of Clow et al. (2005) was re-used in the technical reports by “Scott Wilson Roscoe Postle Associates Inc.”, and “Roscoe Postle Associates (RPA) Inc.”, between 2005 and 2011 as listed in Section 24.0. RESPEC has reviewed this information and believes it can be used for the purposes of this TRS. The reader is referred to Monecke, et al. (2017) and Azevedo, et al. (2022) for more recent and more comprehensive descriptions of the geologic setting, structural evolution and mineralization of the region where Casa Berardi is located.

### 6.1 REGIONAL GEOLOGY

The Property is located in the northern part of the Abitibi Sub province, within the Superior Province of the Archean core of the Canadian Shield. The Casa Berardi area is situated in the Harricana-Turgeon Belt, which is a part of the North Volcanic Zone. The regional geology is characterized by generally east-west assemblages of isoclinally folded and variably foliated and metamorphosed mafic volcanic rocks, flysch-type sedimentary iron formations, graphitic mudrocks, and a large granodioritic to granitic batholith (Figure 6-1). In this TRS, greenschist and higher-grade metamorphic rocks are referred to as the protolith rock types, which follows Hecla’s longstanding usage of terminology for rock units within the region and the Casa Berardi Property.

Regional north-south compression events resulted in tight, kilometer-scale isoclinal folds and rotated the geological units into a vertical position. Structurally, the Property is within the Casa Berardi Break, a 15km wide corridor of strain that can be traced over 200km. Within the corridor, a network of east-west striking ductile, high strain deformation zones mainly follow the lithological contacts. The Casa Berardi Fault was generated during this stage by a movement at the contact of a graphitic unit. Large volcanic units, such as the Dieppe and the Joutel-Raymond domains, have formed competent cores within antiforms. These competent cores forced oblique movement and generated a polyphase elongated dome and basin fold pattern. This tectonic stage corresponds regionally to a 50% shortening and occurs under ductile conditions at a depth of six to ten kilometers.

Many significant deposits of different types have been exploited by past producers in the region. Base metals have been produced from the Joutel (Selbaie Mine, Estrades Mine) and Matagami camps. Farther east, and south of the Casa Berardi structural trend, is the former Telbel Mine of Agnico Eagle Mines Limited (Agnico Eagle). Other deposits have also been described on the Douay, Vezza, and Desjardins properties.

**Figure STYLEREF 1 \s 6-. Regional Geology of Northwestern Québec, Canada**

(from Hecla, 2023; Note that metamorphosed rocks are referred to by protolith nomenclature)

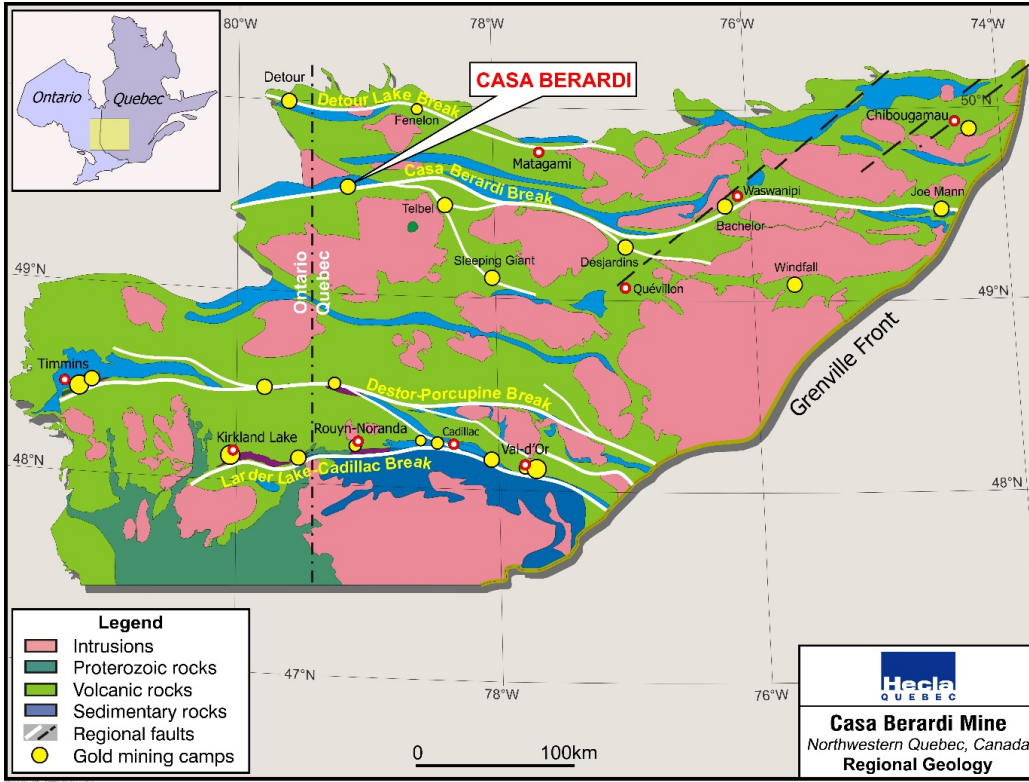

## 6.2 PROPERTY GEOLOGY

### 6.2.1 STRATIGRAPHIC DIVISIONS

The Property is in the Taïbi volcano-sedimentary domain, which is bounded to the north by the Recher Batholith and to the south by various volcanic domains of tholeiitic to transitional affinity (Figure 6-2.). The Dieppe Domain covers half of the southwestern portion of the Property, and the Turgeon Domain lies immediately south of the eastern half of the Property.

Intermediate volcanic rocks of the Joutel-Raymond Group are located within the Turgeon Domain. The Dieppe volcanic unit is defined by thick (up to 100m), massive flows and associated intrusives with sub-ophitic textures. Discontinuous interbedded volcanic and sedimentary units are characterized by breccias, flows, tuffs, and cherty horizons that can be correlated with the Harricana Group. These units are in contact with graphitic sedimentary units and conglomerate in the gold deposit area and the eastern volcanic domain that covers the eastern half of the Property.

40  
40

**Figure STYLEREF 1 \s 6-. Casa Berardi Property Geology**

(from Hecla, 2023; Note that metamorphosed rocks are referred to by protolith nomenclature)

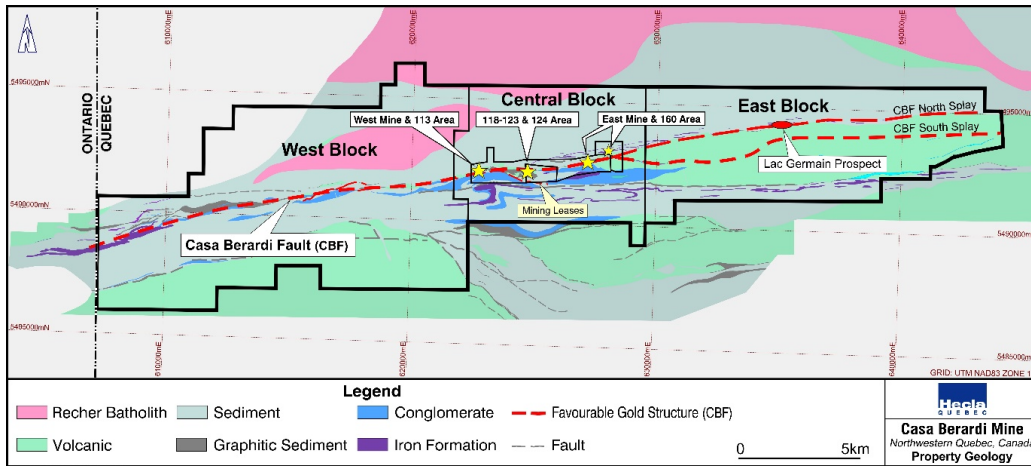

A stratigraphic column for the Property is shown in Figure 6-3. The stratigraphic sequence starts with basal mafic volcanic rock (2,720 Ma to 2,730 Ma?). Pyrite-rich graphitic mudrock and the associated chert appear to be synchronous with the volcanism as evidenced by fragmentary hyaloclastite units of different compositions. The main sedimentary events involved deposition of a flysch sequence. Uranium-lead (U/Pb) dating of the iron formation and conglomerate indicates ages between 2,695 Ma and 2,692 Ma for this sequence.

Overburden, which consists of glacial till and alluvium, covers nearly the entire property. Thickness of the overburden ranges from 10m and 70m, with thicker coverage in the vicinity of the Casa Berardi Fault and thinner away from the fault.

41  
41

**Figure STYLEREF 1 \s 6-. Property Stratigraphic Divisions**  
 (from Hecla, 2023; Note that metamorphosed rocks are referred to by protolith nomenclature)

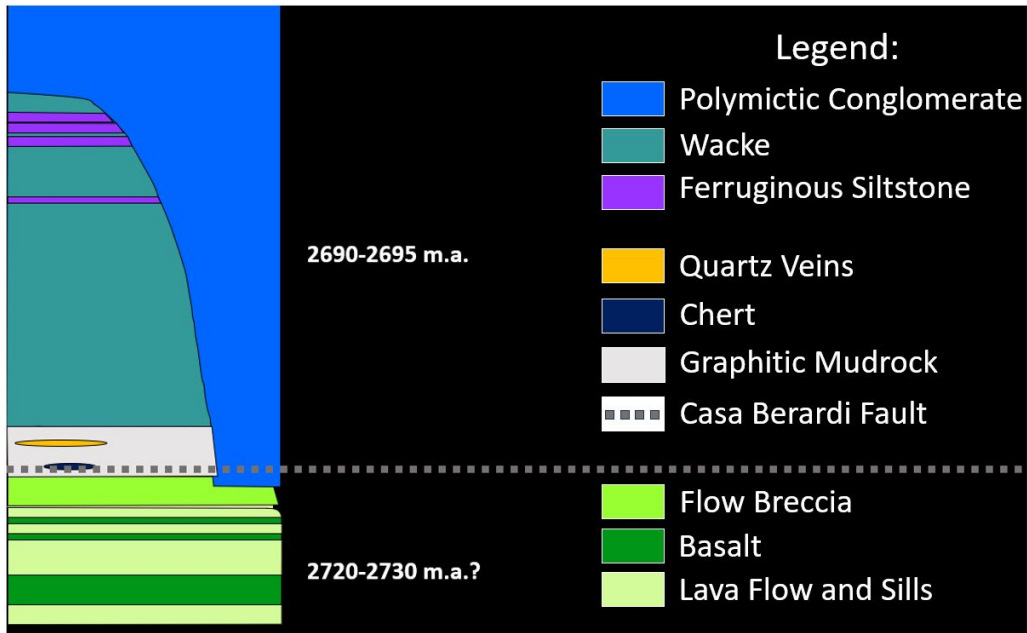

Well-defined flysch-type sedimentary units, like magnetite-rich wacke and conglomerate, can be traced over tens of kilometers without significant facies variations. Volcanic units extend for five kilometers to 15km and appear to form lens shaped bodies. Smaller lenses are a few hundred meters wide and are included in the Casa Berardi Deformation Zone.

Basaltic to andesitic flows, with thickness generally less than 50m, exhibit normal progression facies from coarse crystalline to massive, amygdaloidal, and vesicular in lapilli tuffs and tuffs. Flow contacts are identified by graphitic mudrock horizons. Gabbroic sills, which are related to the Dieppe Domain, are visible near the flow contacts. The Turgeon volcanism is considered a distal, near surface, more evolved volcanic environment. Graphitic rocks (in the form of pyritic and graphitic mudrock), black chert, wacke, and conglomerate form a 500m wide structural corridor that coincides with the Casa Berardi Fault.

### 6.2.2 STRUCTURES

The mafic volcanic units along the Taïbi Domain represent in plan view a lenticular shape corresponding to structural doming. Polarity inversions are recognized in sediments on both sides of their contacts with these units. Tight isoclinal folding forms an asymmetric dome and basin pattern which is well preserved around volcanic units in the iron formations. The main north-south compression event, which is responsible for an 8:1 elongation ratio, is indicated by a strong penetrative east-west foliation.

42  
42

Two fabrics are observed:

- / A constant main penetrative east-west foliation, dipping 60° south.
- / A crenulation cleavage with an undefined oblique orientation related to northeast or northwest fold components. A higher strain rate along main sediment-volcanic contacts has resulted in a small-scale complex dome and basin folding and strong stretching mineral lineation with steep opposite plunges.

The Casa Berardi Fault is defined by a stratigraphic contact between a graphite-rich sedimentary rock sequence at the base of the Taïbi Domain, a northern continuous highly deformed and brecciated mafic fragmentary volcanic unit, and a southern highly deformed polymictic conglomerate unit (Figure 6-4). On the north side of the Casa Berardi Fault, a thick sequence of very homogeneous wacke belonging to the Taïbi Group is affected by amphibolite grade metamorphism. One kilometer north is the easterly elongated Recher Batholith, which is part of the northwestern boundary of the Abitibi greenstone belt.

The Casa Berardi Fault strikes east-west and dips 80° to the south. The Casa Berardi Deformation Zone corresponds to a braided network of laminated high-strain zones following drag-folded contacts of less deformed competent rocks such as mafic volcanic and polymictic conglomerate. The thickness of the affected rock package is used to define a 100m to 500m wide corridor that hosts all the mineralized zones explored and developed at Casa Berardi.

43  
43

**Figure STYLEREF 1 \s 6-. Mine Area Surface Geology**

(from Hecla, 2023; Note that metamorphosed rocks are referred to by protolith nomenclature)

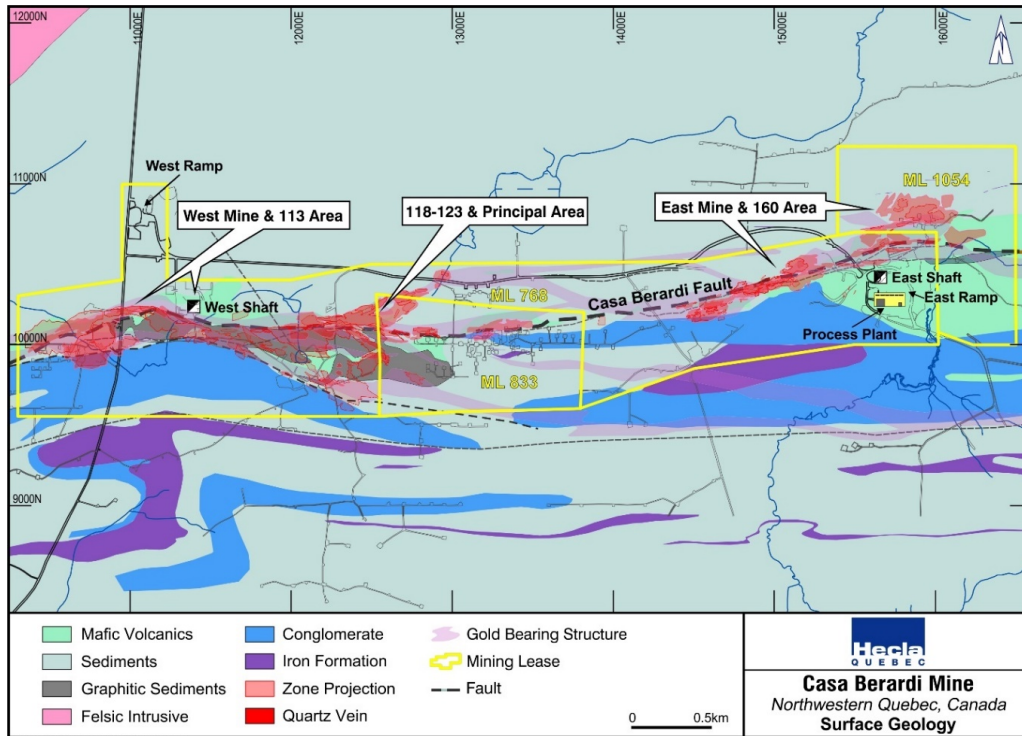

The main brittle deformation and fault zones that have been developed correspond to the Casa Berardi Fault, bounding the strongly metamorphosed Taïbi flysch sediments with interlayered, tuffaceous intermediate units to the north and a package of strongly deformed graphitic sediments, conglomerate, and mafic volcanic flows to the south.

Inside the Casa Berardi Fault zone, ductile deformation intensity is heterogeneous. Foliation is uniform in larger competent rock units, such as mafic volcanic rocks and conglomerates. Kinematic indicators observed inside the main foliation, combined with the foliation dip pattern, indicate a south verging thrust movement.

### 6.2.3 ALTERATION AND METAMORPHISM

The regional metamorphism, which is generally of lower greenschist facies, is locally influenced by a series of syntectonic batholiths with associated thermal aureoles of higher metamorphic grades. The Recher thermal aureole limit follows the northern boundary of the Property, approximately two kilometers from the batholith and the Casa Berardi Fault.

Inside the contact metamorphism halo, the rocks are characterized by a quartz-plagioclase-biotite assemblage. In the case of iron rich sediments, the rocks are metamorphosed to a chlorite-chloritoid assemblage. Garnet is locally visible. Mafic rocks are characterized by a plagioclase-tremolite assemblage. Chloritoid, plagioclase, and garnet are porphyroblastic, with chlorite-biotite pressure shadows indicating the synchronicity of crystallization and regional foliation.

## 6.3 MINERALIZATION

### 6.3.1 STYLES OF MINERALIZATION

Intense folding and metamorphism, and faulting centered on the Casa Berardi Fault, created favorable ground conditions for the deposition of gold mineralization at Casa Berardi. Hydrothermal fluids accessed the fault zone, which was developed along a 30 Ma to 40 Ma unconformity between the mafic volcanics and the flysch-type sedimentary sequence, deposited the gold mineralization and altered the material in the fault zone to silica and clay.

Three principal styles of mineralization have been recognized at Casa Berardi with gold occurring in: 1) quartz veins, 2) stockworks, and 3) banded iron formation. The mineralized zones are closely associated with the Casa Berardi Fault and are found on both sides of the fault. They are restricted to a 500m wide corridor that is folded and plunges lightly to the west.

### 6.3.2 VEINS

Alteration by carbonate-rich fluids tends to be strongest in high deformation zones, generally developed where graphitic mudrock horizons are localized at major rock contacts. This combination of factors acted as a ground preparation for the positioning of vein networks and long veins. The orientation of the veins and internal structures are generally concordant with the ambient fabric. The veins are localized within the foliation and contain two types: foliated host rocks and graphitic planes exhibiting a stylonitic pattern. Vein contacts are usually sharp, and the lack of fabric development indicates relatively late emplacement.

Gold mineralization is largely located in quartz veins, either in the form of multi-meter veins, small-scale veins, or veinlet networks. Veins are heterogeneous and contain a variable percentage of foliated enclaves exhibiting a laminated appearance. Veins are of different color, texture, and structure. Gold grades are generally correlated with increasing complexity. Different quartz phases have been recognized in mineralized veins to exhibit the following sequence:

- / Phase 1: grey quartz, with abundant sulfide and fluid inclusions, comprising more than 50% of mineralized veins;
- / Phase 2: mosaic micro-crystalline quartz occurring in higher grade portions of veins; and
- / Phase 3: non-mineralized coarsely crystallized white quartz which cuts the two other types.

The gold bearing vein filling is rarely massive, but often brecciated, micro-brecciated, or laminated. The fracture planes are rich in graphite and muscovite. Veins contain only 1% to 3% sulfides, predominately arsenopyrite and pyrite, as well as traces of sphalerite, chalcopyrite, pyrrotite, tetrahedrite, galena, and gold. Arsenopyrite is the main gold-bearing sulfide present in all veins of the Casa Berardi deposit.

The granulometric distribution of gold is similar for all locations. According to petrographic compilations, 50% of the gold particles have an average diameter less than 30µm, and approximately 3% are greater than 100µm. The gold distribution inside

45  
45

the mineral assemblage varies slightly according to the location of the mineralized zones. In the 113 Zone of the West Mine area, the vein mineralization, which is spatially close to the Casa Berardi Fault, is mostly free gold in contact with arsenopyrite grains (< 10µm to 0.5mm). Arsenopyrite is associated with sphalerite and tetrahedrite in clusters, joints, and in micro-brecciated areas.

In the Southwest Zone, parts of the Principal area, and some areas of the East Mine mineralization, the gold distribution is variable and depends on the amount of sulfides in quartz veins and host rocks. Fifty percent of gold grains that have been observed are inclusions in pyrite and arsenopyrite crystals.

Alteration halos with gold values greater than 100ppb Au and anomalous values of arsenic and antimony surround most of the mineralized zones along the Casa Berardi Fault. Those halos can be observed up to five kilometers away, on both sides of the Casa Berardi deposit.

### 6.3.3 STOCKWORKS

Stockworks represent nearly the same volume as the large quartz veins. Stockwork mineralization is generally sub-economic, unless they occur in close proximity to larger quartz veins. Across the deposit, hanging wall stockworks are present in contact with important mineralized quartz veins. From 10% to 20% of the rock volume is composed of centimeter to decimeter-wide quartz veins with grades ranging from 1g/t Au to 10g/t Au. Veins of all textures and composition are concordant with host rocks. Foliated and finely bedded rocks are cut by concordant veins. Less deformed basalts or iron rich rocks subjected to alteration by carbonate-rich fluids, are cut by fracture-controlled vein sets.

At the deposit scale, the primary mineralized areas of the West and East mine have stockworks surrounding quartz cores. The stockworks are not limited to the main Casa Berardi Fault and can affect the total width as meter to decameter-wide mineralized subzones.

In the primary mineralized areas of the West Mine, the stockwork extends laterally for 400m at a 50° western plunge. In the East Mine, the overall mineralized system, including stockworks, extends laterally along the strike of the Casa Berardi Fault for 400m, reaching a depth of 800m down dip (Figure 6-5). The system crosses the Casa Berardi Fault at a low angle over 100m of strike length. Mineralization continues to the west on the south side of the Casa Berardi Fault and to the east on the north side of the fault.

### 6.3.4 GOLD-BEARING BANDED IRON FORMATION

Gold-bearing banded iron formation (BIF) is found in the 124-8, 124-1, and 116 zones of the Principal area, at the western extension of the East Mine pit in the 148-09 Zone, and at the extension of the East Mine area in the 160 Zone. These zones are restricted to the highly sheared, brecciated, and altered ferruginous sedimentary units occurring north of the Casa Berardi Fault. Mineralization occurs within meter to sub-meter quartz veins and stockworks with up to 10% chert-magnetite beds, and exhibits high sulfide content which consists of pyrite, arsenopyrite, traces of pyrrhotite, and little or no visible gold. These sulfides have replaced the oxide rich layers which surround the quartz veins and the veinlet stockworks. Strong carbonate and chlorite alteration halos surround the quartz rich areas.

46  
46

### 6.3.5 MINERALIZATION NEAR THE WEST MINE INFRASTRUCTURE

The mineralized zones in the vicinity of the underground infrastructure of the West Mine are all located between sections 10, 350E and 11,250E, which correspond to the western limit of the Lower Inter Zone and the eastern limit of the 111 Zone, respectively (Figure 6-5). Mineralization occurs at the Casa Berardi Fault (in the 109, 111, 113, NW, NE zones), between the Casa Berardi Fault and the South Fault (in the 104, Inter, Lower Inter and 115 zones), and at the South Fault (in the South West zone).

Mineralization at the West Mine is represented by two main types:

- / Low-sulfide quartz veins: networks of centimeter to multi-meter quartz veins located south of the Casa Berardi Fault in highly deformed volcanic and sedimentary rocks that are predominantly basalt, wacke, conglomerate, chert, and mudrock; and
- / Sulfide-rich stockworks: these represent the same volume as large quartz veins but have lower grades and are largely unexploited. Hanging wall stockworks are present in contact with important mineralized quartz veins across the Casa Berardi deposit.

47  
47

**Figure STYLEREF 1 \s 6-. Section 11,385E, West Mine Including the 113 Zone and Casa Berardi Fault**  
 (from Hecla, 2023; Note that metamorphosed rocks are referred to by protolith nomenclature)

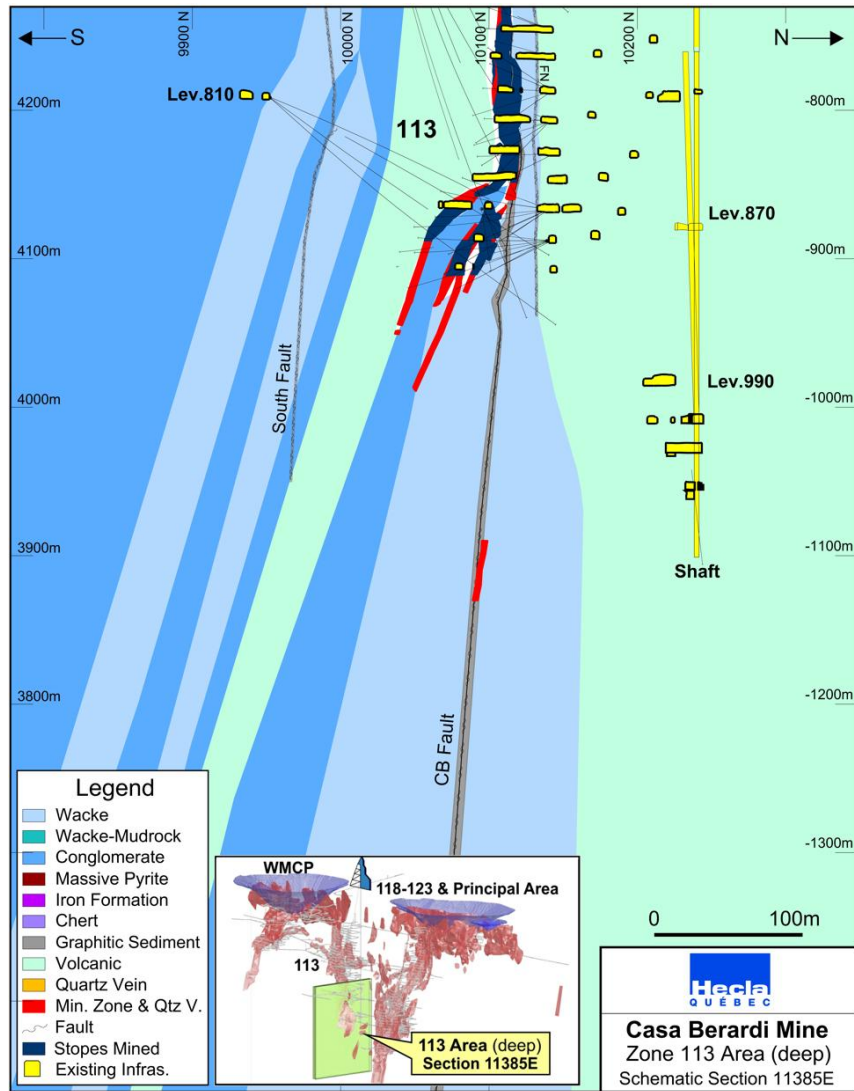

The modeled mineralization for pit resource evaluation at the West Mine Crown Pillar (WMCP) is designated the 105 to 114 zones and occurs west of the West Shaft and from the surface to the 450m level. They include stacked quartz veins occurring at the Casa Berardi Fault above the 330m level in the Northwest, Northeast, 111 and 113 zones. Between the Casa Berardi

48  
 48

Fault and the conglomerate to the south, the Southwest (107), Southeast, and Inter (108) zones contain mineralized quartz veins with graphitic and sericitic schists with sulfides inside the South Fault corridor. The orientation of mineralization is mainly east-west with a south dip of 50° to 60°. Visible gold is associated with the veins. There is a low content of sulfides, primarily pyrite with traces of arsenopyrite. The mineralization plunges west at 15° and is open to the west along the South Fault. Further east, mineralization has a plunge of 20° east and is open to the south from the 100m level to the 450m level.

The Southwest (107-02 and 107-03 lenses) area occurs as meter to multi-meter quartz veins stacked along the South Fault and folded near the surface. The strike of the lenses is variable from east-southeast and dipping to the south at 50° to 60°. The Inter Zone (108-01, 02 and 04 lenses) occurs between the Casa Berardi Fault and the South Fault. The mineralized structure is located at the contact between the graphitic sedimentary units and a mafic volcanoclastic unit. The orientation of the mineralized structures is generally east-southeast striking with a shallow dip to the south of 5° to 45°. The zones typically extend 150m along strike and 75m along dip. The upper portion of the Inter Zone is connected to the Northeast Zone and its lower portion connects with the Southwest Zone. The type of quartz vein and mineralization is quite similar to the veins observed in the Lower Inter Zone.

### 6.3.6 MINERALIZATION ALONG THE CASA BERARDI FAULT

Mineralized zones such as the Northeast, Northwest, and 109 occur at the Casa Berardi Fault in the form of meter to multi-meter quartz veins. Veins occur over a distance of 330m along strike and from 250m to 550m elevation and have a direction which varies from northeast to nearly east-west with a sub-vertical dip. The 109 Zone has a sub-horizontal dip at its western limit and a steeper dip to the east where it connects to the 113 Zone.

The 113 Zone is a mineralized corridor with a width ranging from 20m to 70m. The strike length ranges from 150m at the 250m level to over 400m at the 550m level. This mineralization strikes east-southeast and dips to the south at 75°. From the 450m level to 800m level, the strike varies from east-west to east-southeast, with a sub-vertical dip (Figure 6-6). From the 810m level to the 1,000m level, mineralization occurs as meter quartz veins with visible gold and traces of fine disseminated pyrite and arsenopyrite. The zones strike north-northeast and dip to the southeast at 70°. The zones have a steep plunge to the east and the 113 Zone is open along the plunge and at depth.

### 6.3.7 MINERALIZATION BETWEEN THE CASA BERARDI AND SOUTH FAULTS

The Lower Inter, Inter, and 115 zones are relatively flat dipping and plunge at approximately 15° to the west on the flat portions. The zones become steeper and are disrupted by minor thrust faults near the Casa Berardi Fault and near the South and Lower Inter Faults.

The Lower Inter Zone (the 100 Zone) is located between the 375m level and 600m level, and from sections 10,525E to 10,360E. The Lower Inter Zone dips from 25° to 45° south and plunges to the west at 15°. The zone is controlled by the Casa Berardi and the Lower Inter faults and lies on top of the folded wacke-basalt contact (Figure 6-6). The thickness of the quartz vein varies from four meters to 50m, with the maximum thickness observed just beneath the contact of the two faults. The thinner quartz veins are observed down-dip, along the Lower Inter Fault, and extend for approximately 200m. Stacking of quartz veins is observed in a deformation zone that is located at the lithological contact between the footwall mafic volcanic rock and the hanging wall graphitic mudrock.

49  
49

The Inter Zone is located from sections 10,600E to 10,950E, and from the 150m level to the 310m level. The mineralized structure is located at the contact between the graphitic sediments and a mafic volcanoclastic unit. The mineralized structure strikes southeast with a shallow dip to the south (5° to 45°) and extends 150m laterally and 75m along dip. Its upper portion is connected to the Northeast Zone where the quartz vein and mineralization are similar to the Lower Inter Zone.

The 104 Zone corresponds to the Lower Inter Zone that is steeply plunging to the west. The 104 Zone strikes east-northeast, dips to the southeast at 70°, and it is composed of quartz veins with visible gold and low sulfide content.

**Figure STYLEREF 1 \s 6-. Section 10,800E, West Mine Geology and Mining Infrastructure**

(from Hecla – Casa Berardi, 2023; Note that metamorphosed rocks are referred to by protolith nomenclature; heavy blue line shows limits of open pit as of 2023)

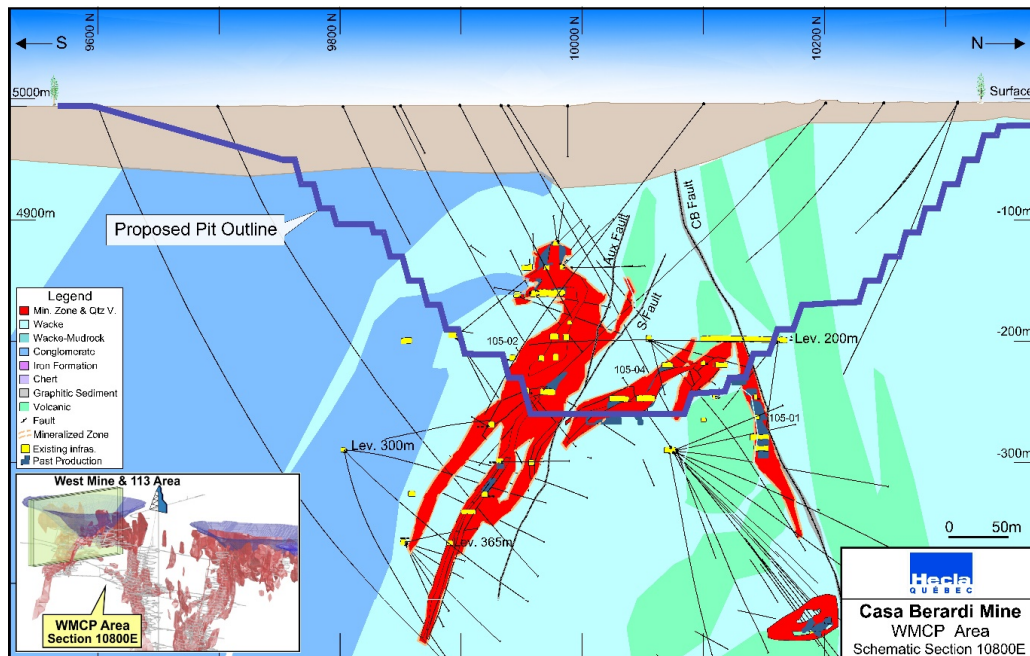

### 6.3.8 MINERALIZATION AT THE SOUTH FAULT

In plan view, the Southwest (107) and Southeast zones can be interpreted as a dome that is cut by the South Fault and by the subsidiary Auxiliary Fault. The mineralized system extends 200m laterally and 300m along dip, extending from surface to the 300m level.

The main quartz vein structures are developed at the contact between a conglomerate and a graphitic mudrock and are associated with a large stockwork of disseminated sulfides. The internal vein structure shows variable orientations and is, in many places, brecciated. The mined and potentially mineable mineralization extends down dip and is represented by a system of parallel veins which dip at 60° southwest.

### 6.3.9 MINERALIZATION AT THE 118 ZONE

The 118 Zone occurs from section 11,600E to 12,400E, between the 400m and 1,200m levels (Figure 6-7 and Figure 6-8). The mineralization occurs within a 20m to 70m wide mineralized corridor south of the Casa Berardi Fault. The 118-10, 20, 21, 22, 27, 64, 81, 82, and 118-83 zones are stacked meter to sub-meter quartz veins with a sericite-carbonate envelope and high sulfide content, mainly arsenopyrite and pyrite with local visible gold. The zones contain up to 20% of meter to sub-meter quartz veins and veinlets sub-parallel to the schistosity. The zones strike east-southeast and dip to the southwest at 60° to 80°. The high-grade zones show a steep plunge to the southwest at 70°. The 118-06 Zone is similar to the 118-27 lens, with the same orientation and dip. The structure is also well mineralized within the conglomerate unit and represents a strongly mineralized quartz stockwork with fine- to coarse-grained arsenopyrite and pyrite with visible gold. The upper part of the zone from the 330 to 610 level is folded and stacked. The general strike is east-southeast and dips to the southwest at 60° to 80° and follows the west plunge of the conglomerate. At the 330 level, the mineralization connects with the 124-81 and 82 zones. The 118-14, 15, 41, 42, 43, 44, 45, 46, and 47 zones are meter to multi-meter quartz veins along the upper contact of the conglomerate unit and along its plunge. The quartz veins are locally faulted with a minor thrust fault and plunge to the west at approximately 15° to 20°. The 118-05, 11, 12, 13, 31, and 34 zones are meter to multi-meter stacked quartz veins and quartz stockwork along the Casa Berardi Fault with an east-west strike and south dip at 60° to 80°. Mineralization consists of fine to medium grained disseminated arsenopyrite, pyrite, sphalerite, and visible gold associated with quartz veins. The 118-16 and 17 zones are characterized by sericite-carbonate schist with a high sulfide content, mainly arsenopyrite and pyrite, with local visible gold. They contain up to 20% meter to sub-meter quartz veins oriented east-southeast and dipping southwest at 70°. The mineralization follows the plunge of the 113 Zone along the conglomerate. Thickness of the veins ranges from three to five meters with east-southeast strike and dip southwest at 70°. Mineralization remains open at depth and along the plunge of the conglomerate.

**Figure STYLEREF 1 \s 6-. Plan View of the 1,010m Level, Principal Area**

(from Hecla – Casa Berardi, 2023; Note that metamorphosed rocks are referred to by protolith nomenclature)

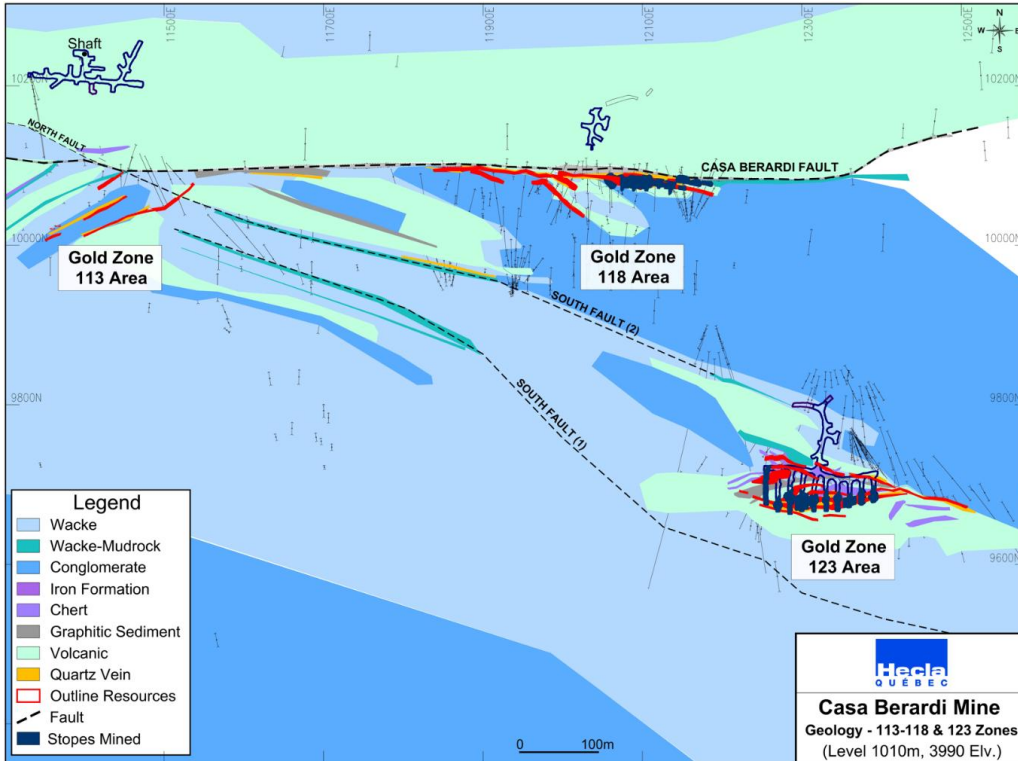

### 6.3.10 MINERALIZATION AT THE 123 AND 128 ZONES

The 123 Zone occurs in the South Domain of the Casa Berardi Deformation Zone and consists of stacked quartz veins and stockwork, varying in width from approximately five meters to 30m, within a sequence of highly deformed and altered volcanic rocks and chert, at the sheared contact of volcanic and sedimentary rocks, and close to the faulted southern contact of the conglomerate that hosts the 118 Zone (Figure 6-7 and Figure 6-8). Mineralization in quartz veins occurs as disseminations and stringers of pyrite, pyrrhotite, and arsenopyrite, with fine visible gold and minor disseminations of sphalerite. The veins near the chert bands strike east-northeast while dipping to the south at 60° to 70° and plunging to the east at 80°. The veins near the volcanic and sedimentary rocks strike west-northwest with subvertical to 70° south dips. Mineralization occurs at the surface in lenses 123-21, 23, and 24 and the mineralization is open at surface and at depth to the west.

The 128 Zone is located on section 12,800E at the 400m level and is located at the same stratigraphic horizon as the 123 Zone within fragmental volcanic rocks. The 128 Zone is composed of quartz veins with visible gold. The mineralization has an east-west strike and a vertical to sub-vertical dip to the south. The 128 Zone is open at depth and along strike.

**Figure STYLEREF 1 \s 6-. Section 12,330E, Principal Area Geology 118, 123, and 124 Zones**

(from Hecla – Casa Berardi, 2023; Note that metamorphosed rocks are referred to by protolith nomenclature; heavy blue line shows limits of open pit as of 2023)

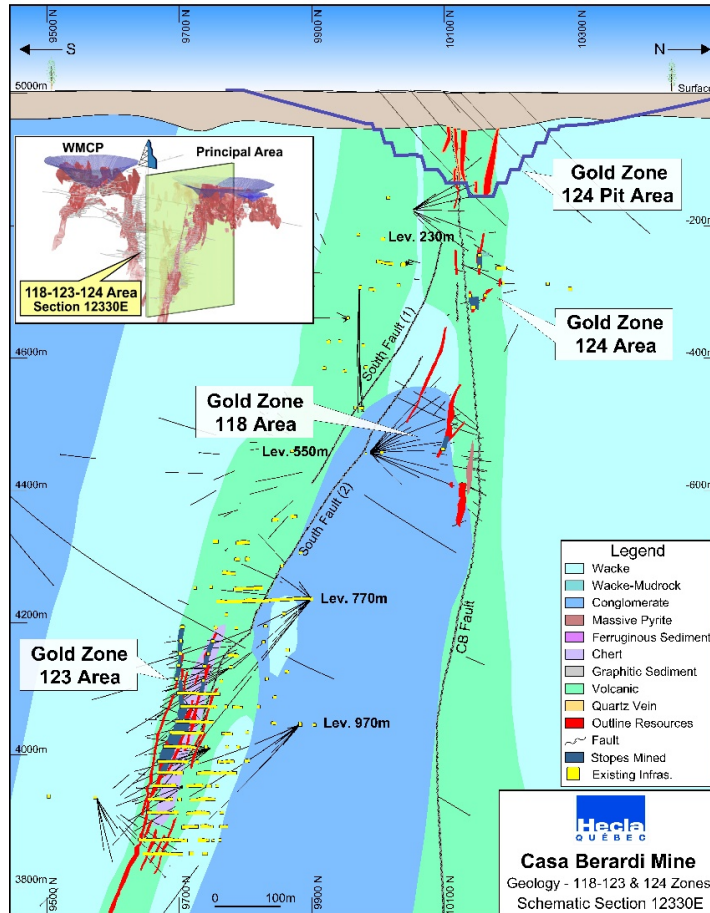

### 6.3.11 MINERALIZATION AT THE PRINCIPAL MINE AREA

Mineralization within the Principal Zone occurs near the surface to the north and south of the Casa Berardi Fault and extends to depth to the 118 Zone along the Casa Berardi Fault and to the 123 Zone in the South Domain of the Casa Berardi Deformation Zone (Figure 6-9). The zones are located between section 11,900E and section 13,000E.

54  
54

RSI-M0206.22001

---

**Figure STYLEREF 1 \s 6-. Plan View of the 290m Level, Principal Area Including the 124 Zone Lenses**

(from Hecla – Casa Berardi, 2023; Note that metamorphosed rocks are referred to by protolith nomenclature)

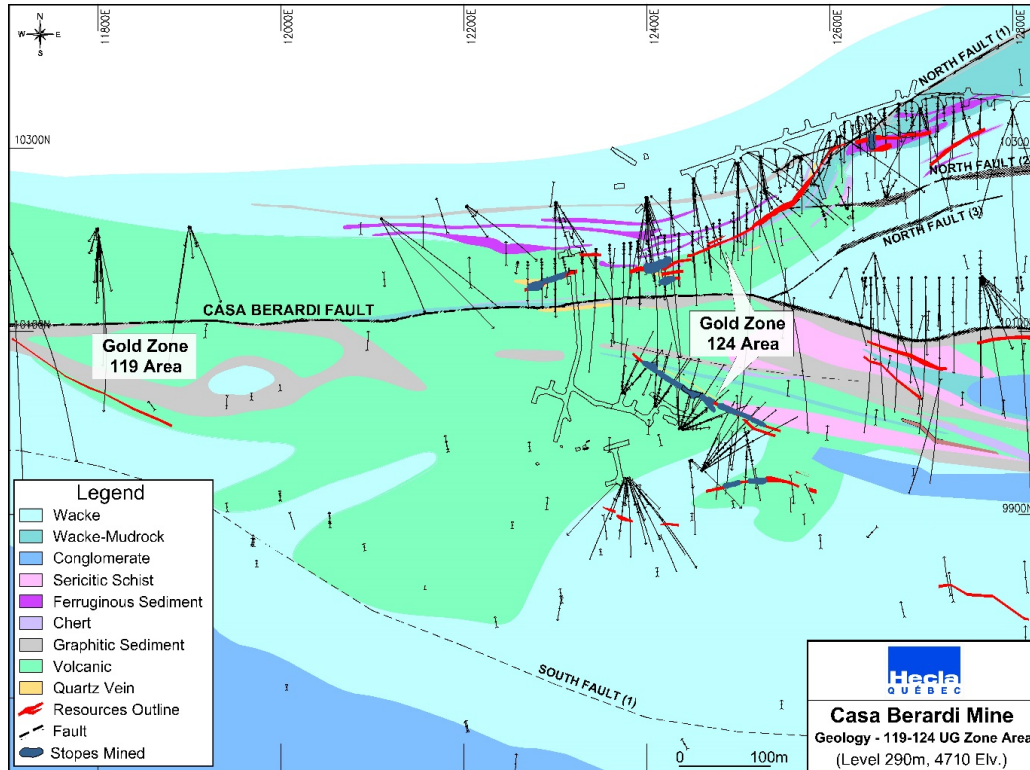

South of the Casa Berardi Fault, Zone 124-3 occurs as stacked, meter-wide, quartz veins near the Casa Berardi Fault, and is the up-dip extension of the 118 Zone occurring on top of the conglomerate. The overall orientation is east-southeast with dips to the southwest at 50° to 80° with a plunge to the southeast of 50°. Mineralization consists of arsenopyrite, pyrite, and visible gold with quartz veins. Zones 124-11 and 124-22 occur along secondary structures south of the Casa Berardi Fault and connect at depth with Zone 123-05. The zones occur in a corridor of meter-wide quartz veins and veinlets with visible gold, fine disseminations of arsenopyrite, and traces of sphalerite. These zones are oriented east-southeast and dip to the southwest at 60°.

Zones north of the Casa Berardi Fault (124-6, 124-8, 124-12, 124-13, 124-14, 124-16, 124-17) appear within highly sheared, brecciated, and altered ferruginous sediments between or near chert bands with minor magnetite. Gold mineralization occurs within meter to sub-meter quartz veins and stockworks containing fine grained to massive pyrite and arsenopyrite, traces of pyrrhotite, and very minor visible gold. Alteration is primarily chloritization and carbonatization (calcite and ankerite), with sericitization along the quartz veins. The strike varies from east-west (124-6) to east-northeast (124-8, 124-12, 124-13,

55  
55

124-14, 124-16, 124-17) with dips to the south at 70° to near-vertical, and the zones plunge to the east at 50°. Mineralization remains open to depth and to the east of the 124-16 Zone.

The mineralized lenses in the 134 Zone are located between sections 13,100E and 13,500E and between the surface and level 300. Mineralization consists of arsenopyrite, pyrite, and visible gold with meter to multi-meter quartz veins and ankerite, sericite schist occurring within a sequence of highly deformed and altered volcanic rocks and sediments at the Casa Berardi Fault and north of the Casa Berardi Fault along secondary graphitic faults. The overall orientation is east-northeast with dips to the southeast at 75° and a plunge to the southeast of 60°.

### 6.3.12 MINERALIZATION AT THE EAST MINE AREA

The mineralized zones in the East Mine area are located between sections 14,000E and 16,300E and from surface to the 1050m level (Figure 6-10). The East Mine area has remaining underground Mineral Resources in the 146, 148, 152 157, 159 and 160 zones and pit resources and reserves in the 159 and 160 zones.

The 146 zone occurs between sections 14,400E to 14,725E. Mineralization appears 30m south of the Casa fault. It is composed of massive veins and fine disseminations of pyrite and pyrrhotite with 5-10% quartz veins in stockwork within a highly altered wacke and iron formation north of the conglomerate unit. Little mineralization appears at the Casa Berardi Fault. The mineralization corridor has an east-northeast direction and dips south at 75°. Mineralization is still open at depth.

The 148 Zone appears mainly at the Casa Berardi Fault, the strike of the lenses varies from east-southeast to west-northwest with a steep dip to the north, showing an anastomosing pattern. Between surface and the 200 level, the mineralized envelopes are composed of quartz veins and quartz stockwork several meters thick and mineralized with fine disseminated pyrite, arsenopyrite and visible gold. Mineralization appears mainly at the Casa Berardi Fault, the strike of the lenses varies from east-southeast to west-northwest with a steep dip to the north, showing an anastomosing pattern. Between the 200 and 550 levels, the mineralization is restricted to a continuous 10-meter-wide vertical quartz vein which is parallel to the Casa Berardi Fault. Between the 550 and 1050 levels, the quartz veins are meter to multi-meter thick and strike east-northeast with south dips varying from 60° to 85°. Mineralization is still open at depth and along strike.

The 152 Zone lies to the north of the Casa Berardi Fault, with a vertical extent of 200m, from section 15,050E to section 15,250E, and from the 100m level to 300m level, and is laterally continuous over 100m (Figure 6-10 and Figure 6-11). Stacked quartz veins are concentrated at the sheared mafic volcanic-wacke contact. The dip and thickness of the mineralization are highly variable.

Figure STYLEREF 1 \s 6-. East Mine Composite Longitudinal Section

(from Hecla – Casa Berardi, 2023)

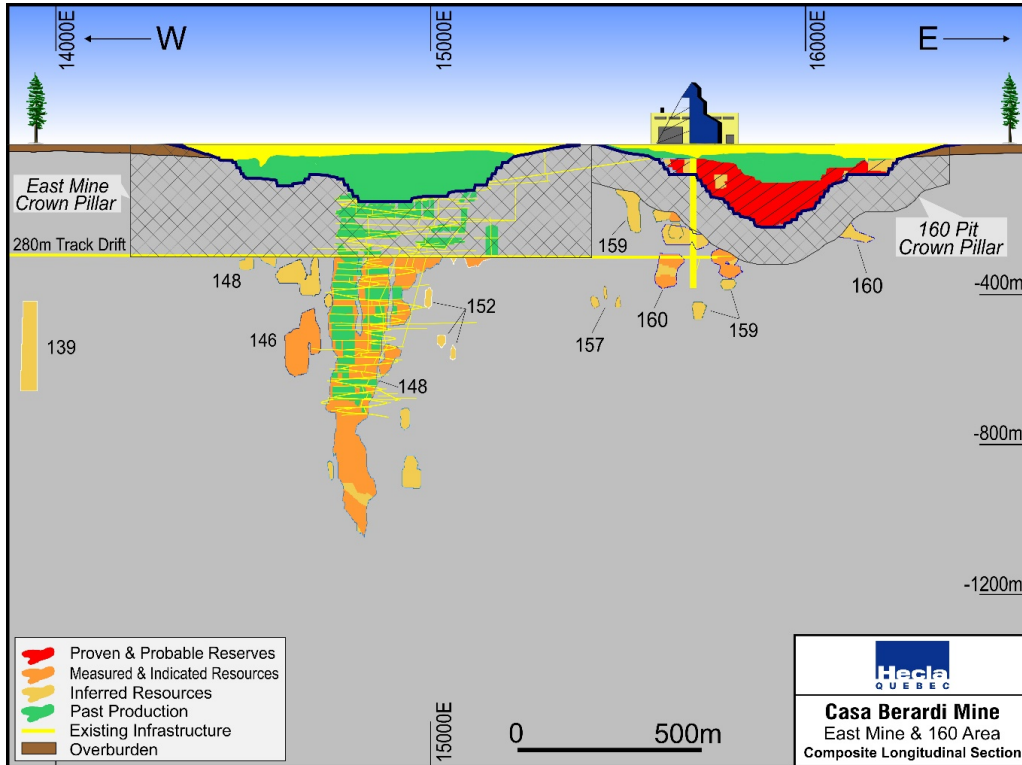

The 157 Zone appears from section 15,400E to 15,500E, 130m south of the Casa Berardi Fault. It shows one-meter-wide high-grade quartz veins within the mafic volcanics. The orientation of the veins is east-north-east and dipping to the south-east at 70°. The mineralization is open laterally and at depth below the 400m level.

The 160 and 159 (Cherty) Zones are located between sections 15,400E and 16,300E and are 200m and 30m north of the Casa Berardi Fault, respectively. Lenses that are parts of the zones have an average lateral extent of 200m and a vertical extent of 100m, down to the 350m level (Figure 6-11).

The 159 Zone occurs north of the Casa Berardi Fault and east of the 152 Zone. Mineralization is composed of stacked meter to sub-meter quartz veins and veinlets occurring near a band of chert north of the Casa Berardi Fault and near the contact between the volcanic rocks and the sediments north of the Casa Berardi Fault. General orientation of the quartz veins is east-northeast with dips to the south at 70° to 75°. Mineralization remains open at depth and to the east.

Mineralization in the 160 Zone occurs at or near the sheared contact of pyroclastic rocks and fine-grained sedimentary units, mainly wacke, graphitic mudrock, and meter to multi-meter thick ferruginous sediments and along a secondary graphitic fault. Two sets of veins appear in the resource: the main vein system associated to the east north-east graphitic fault and the vein system associated to the north-north-west graphitic faults. The main vein system is generally east-northeast with dips to the south at 65° to 75°. Mineralization is composed of meter to sub-meter quartz veins and stockworks containing fine pyrite and arsenopyrite, traces of pyrrhotite, and visible gold. Alteration is predominately chloritization and carbonatization (calcite and ankerite), with sericitization along the quartz veins. The vein system associated to the north-north-west graphitic faults are oriented west-northwest direction, dipping to the south-west at 40°. The 160 Zone mineralization exhibits a shallow plunge to the west-southwest at 40°.

**Figure STYLEREF 1 \s 6-. Section 15, 840E, East Mine Geology and Infrastructure – 160 Zone**

(from Hecla – Casa Berardi, 2023; Note that metamorphosed rocks are referred to by protolith nomenclature; heavy blue line shows limits of open pit as of 2023)

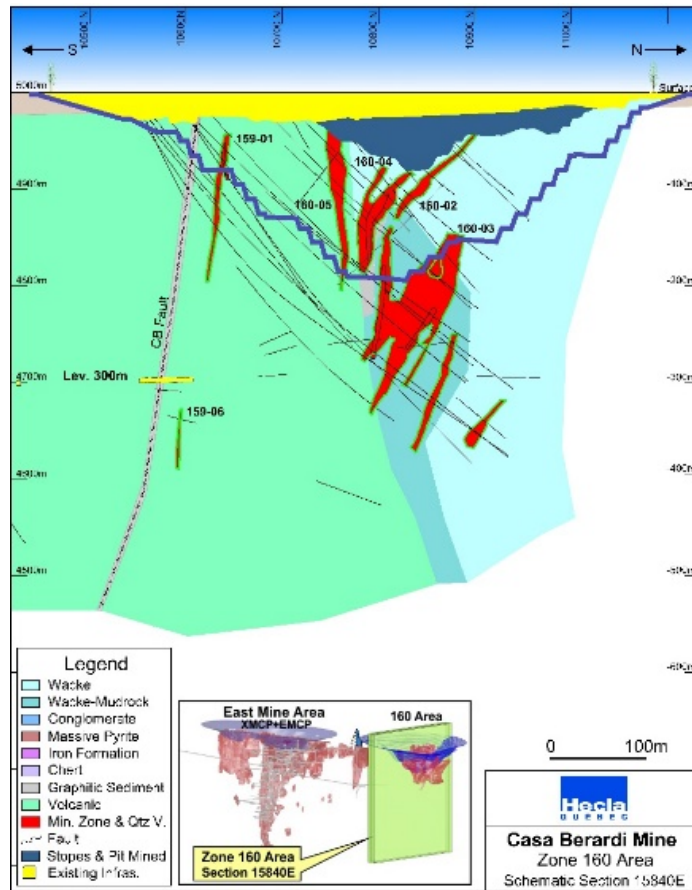

## 6.4 DEPOSIT TYPES

The Casa Berardi deposit can be classified as an Archean-age, sedimentary-hosted lode-gold deposit. Gold deposits of the Archean Abitibi greenstone belt predominantly consist of epigenetic disseminated and vein-hosted deposits, and syngenetic gold-rich massive sulfides (Robert et al., 2005; Monecke et al., 2017). Both types of mineralization could potentially occur within the same deposit in areas where deformation and metamorphism overprint volcanic successions. Deformation and metamorphism can significantly modify the mineralogy and geometry of previously formed mineralization. Nevertheless, superposition of hydrothermal events, metamorphism, and deformation, represent important processes for gold concentration and the formation of world class lode gold deposits in greenstone belts and sedimentary rocks in general (e.g., Dubé et al. 2007; Large et al., 2007).

The Casa Berardi gold mining camp in the northern Abitibi greenstone belt contains different styles of mineralization within the same deposit including gold-rich massive sulfides, auriferous pyritic and carbonaceous phyllite and chert, and pyrite-arsenopyrite-gold-quartz veins. It is therefore considered an ideal setting to study the effects of superimposed hydrothermal systems and to contribute to a better understanding of Casa Berardi and prospective areas along the extensive Casa Berardi Deformation Zone.

## 7.0 EXPLORATION

This section of the TRS summarizes exploration work carried out by Hecla since acquiring the Casa Berardi Property in 2013. The information summarized herein has been provided by Hecla. RESPEC has reviewed this information and believes it is materially correct.

### 7.1 HECLA EXPLORATION 2014 TO 2023

Since Hecla's acquisition of Casa Berardi in June 2013, exploration activities have largely consisted of staking and acquiring new claims, core drilling, geophysical surveys, drill-hole re-logging and drilling data compilation and integration. Details of Hecla's drilling is summarized in Section 7.2 and Section 7.3. The majority of Hecla's exploration and delineation drilling since 2014 was core. 103 sonic holes have been drilled, for exploration till and bedrock sampling, mostly outside of the mining lease. No RC holes or other holes were drilled.

#### 7.1.1 2016

From 2012 to the end of 2016, Casa Berardi was still under a JV between Lake Shore and Hecla. No exploration work was carried out in the field. After Hecla purchased Tahoe's 50% interest in the Property at the end of 2016, Hecla resumed data compilation and integration to generate drill targets.

#### 7.1.2 2017

In the winter of 2017, Hecla conducted a 19-hole (6,620m) drilling program in the West Block between the West Shaft and the former Agnico Eagle claim block. Hecla's geologists also re-logged and sampled 47 Lakeshore drill holes totaling 20,910m from Lac Germain and the West Block for lithogeochemistry. During autumn 2017, a helicopter-borne versatile time domain electromagnetic (VTEM) and horizontal magnetic gradiometer geophysical survey, totaling 1,587 line-km, was flown over the entire Property.

The 2017 exploration program was successful in defining new mineralization to the west of the Casa Berardi Mining Lease. Drilling on the West Block succeeded in discovering new gold mineralization. In hole CBS-17-783, the best assay result was 1.57g/t Au over 3.5m and mineralization is related to the 30% pyrite and trace arsenopyrite in a sericitized and silicified wacke. In hole CBS-17-788, two intervals of quartz veins stockwork with up to 10% pyrite and trace arsenopyrite yielded 4.49g/t Au over one meter and 4.76g/t Au over 1.7m at borehole depths of 135m and 235m, respectively. Drilling and relogging succeeded in improving the geological model and furthering Hecla's understanding of the West Block and Lac Germain, by confirming exploration potential and delineating exploration targets for 2018.

#### 7.1.3 2018

During the winter of 2018, Hecla drilled 13 follow-up drill holes (4,610m) on near surface targets on the West Block and 27 holes (6,656m) on the Lac Germain prospect. A bridge was built over the Theo River to improve access to the Lac Germain area. Relogging of 46 holes from previous drilling on the East and West Blocks was also completed.

60  
60

At the West Block, the most significant mineralization was in hole CBS-18-959 that intersected 73.1m of chloritized felsic quartz porphyry volcanic rock with up to 30% pyrite in semi-massive to massive beds and stringers (from 182.1m to 253.4m). Assays returned 1.23g/t Au over 19.1m including a massive sulfide section that yielded 3.76g/t Au over 1.8m.

At the Lac Germain prospect, drilling succeeded in intersecting wide, high-grade gold-bearing mineralized zones. Mineralization was interpreted in six gold-bearing subparallel lenses, LG 1 to LG 6, forming a 100m-wide corridor in a sequence of wacke and BIFs. These lenses strike at approximately 070° and dip between 65° to 75° to the south. In the LG 1 Zone, hole CBS-18-955 returned 11.31g/t Au over 3.6m including 25.30g/t Au over 1.2m. In the LG 2 Zone, hole CBS-18-940 returned 5.5g/t Au gold over four meters and hole CBS-18-942 returned a value of 461.0g/t Au over 0.6m. In the LG 3 Zone, holes CBS-18-935 and CBS-18-947 returned 5.61g/t Au over 3.3m and 4.08g/t Au over 2.6m, respectively. In the LG 4 Zone wide intersections of 5.22g/t Au over 6.5m in CBS-18-955, 3.66g/t Au over 8.4m in CBS-18-960, and 5.97g/t Au over 4.5m in CBS-18-968, were reported. Gold-bearing mineralization was interpreted to be related to quartz and quartz-carbonate veinlets and veins up to 1.5m thick. The veins contained minor amounts of pyrite, pyrrhotite, and arsenopyrite, and gold grades correlated with the amount of arsenopyrite. Visible gold was related to traces of sphalerite and galena.

#### 7.1.4 2019 AND 2020

No drilling was completed for regional exploration in 2019 and 2020.

#### 7.1.5 2021

In 2021, relogging of eight drill holes totaling 3,055m on the Dieppe East Block confirmed that the geology of the Dieppe East Block is similar to the geology intersected in drill holes from 2017 and 2018 consisting of graphitic mudstone with nodular pyrite, felsic and mafic volcanic rocks, and major graphitic faults (Casa Berardi Deformation Zone). In addition, eight drill holes totaling 3,675m from the Dieppe 1 mineral occurrence were relogged.

This drill-hole relogging confirmed that gold mineralization is related to quartz veins in a brecciated chert horizon at the contact within mafic volcanic rocks. Importantly, the area around the Dieppe 1 mineral occurrence is characterized by a strong volcanogenic massive sulfide mineralizing system, with massive sulfide zones up to 150m thick. Minor gold mineralization is hosted by these massive sulfide zones, but there is potential for discovery of volcanogenic massive sulfide deposits with more significant gold grades elsewhere in the Casa Berardi area.

In 2021, Hecla drilled 5,879m in 12 drill holes on the West Block area and intersected anomalous values that extended previously identified mineralization at depth within both quartz veins and bedded massive sulfides, although these intercepts were low grade. Drill hole CBS-21-023 intercepted massive sulfides over 15m in thickness and returned anomalous gold values over 20m down hole. Further west, drill hole CBS-21-017 confirmed mineralization at depth and extended the mineral zone over hundreds of meters down plunge intercepting 6.90g/t over 3.6m. The geology and mineralization have strong similarities to the 123 and 124 mining zones within the Central Block at Casa Berardi.

#### 7.1.6 2022

In 2022, an orientation drilling program was conducted with one Sonic rig focused on a gold overburden anomaly and favorable geology to generate future core drilling targets. The programs covered the East, Central and West block of the property with 103 drillholes for 3,386m. One strong gold dispersal train was defined on the East Block south of the north

61  
61

splay of the Casa Berardi Fault. The West Block results showed a gold dispersal train that still open to the west and suggest a gold source east of the anomaly.

### 7.1.7 2023

In 2023, exploration focused on core drilling to define the gold sources of the overburden till anomalies highlighted in 2022. Ten holes totaling 3,266m were drilled over the property. Six of the holes, totaling 1,700m, were drilled on the West Block and four holes, totalling 1,565m, were drilled on the East Block. The 2023 drilling intersected gold and arsenopyrite mineralization, strong quartz veins, and favorable geology and structural setting along the East Block that can be related to the gold till anomaly partially identified in 2022. The West Block drilling highlighted new lithologies, a strong alteration halo and quartz veins on both sides of the north splay of the Casa Berardi Fault. Casa Berardi geologists were able to refine knowledge of the sector and geological settings that can host gold mineralization to generate the till anomaly of the East Block. The results and observations collected in 2023 continue to demonstrate the potential of the Casa Berardi break.

## 7.2 DRILLING SUMMARY

From 1988 to 2023, surface and underground diamond drilling totaled more than 2.5 million meters at Casa Berardi. Of that total, 858,047 meters have been drilled in 5,310 holes by Hecla since acquisition of the Property in 2013. Most of this drilling has successfully expanded known mineralization along a five-kilometer segment of the Casa Berardi Fault in the immediate mine area. Some regional exploration work including geophysical surveys and diamond drilling has been carried out on the Property, which is extensive and covers a favorable geological environment for gold mineralization including a 37km strike length along the Casa Berardi Fault. Geophysics and drilling are the key exploration tools needed to make new discoveries under the thick layer of overburden that covers most of the Property. Drilling locations within the property are shown in Figure 7-1. The main exploration and definition drilling programs are summarized in the following sections.

Figure STYLEREF 1 \s 7-. Map of all Historical and Hecla Diamond Core, RC, and Sonic Drilling  
(from Hecla – Casa Berardi, 2023)

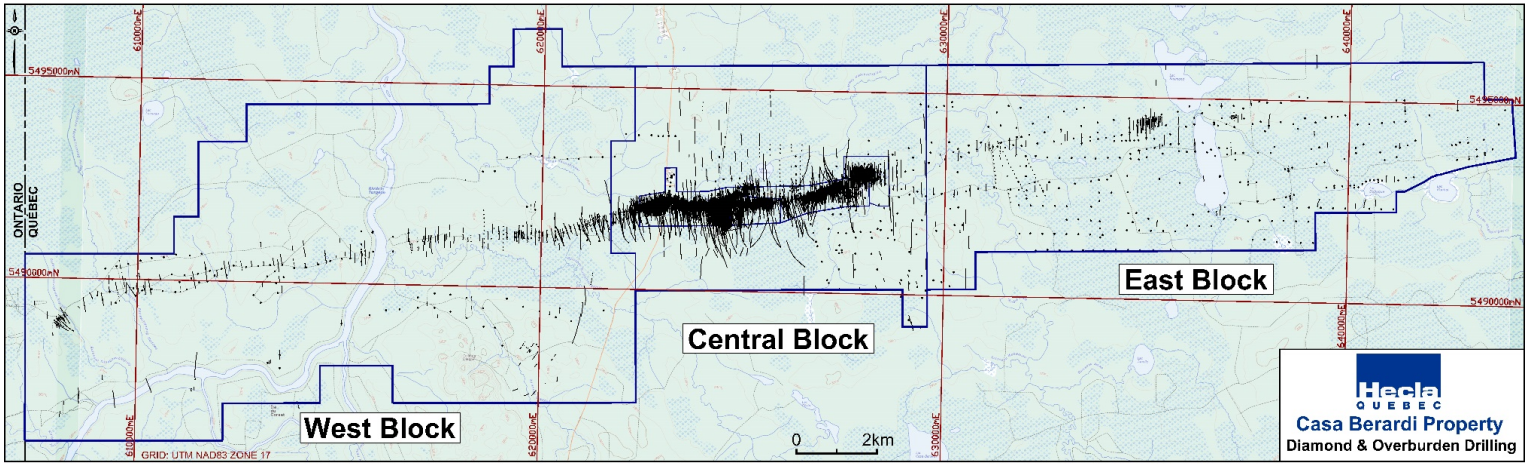

**Table STYLEREF 1 vs 7-. Hecla Surface and Underground Drilling 2014 – 2023**

Company	Year	Surface		Underground		Total	
		Holes	Meters	Holes	Meters	Holes	Meters
Hecla	2014	47	14,835.50	604	54,878.80	651	69,714.30
	2015	66	28,524.67	646	69,373.00	712	97,897.67
	2016	101	22,865.60	580	62,043.80	681	84,909.40
	2017	298	71,505.30	419	61,381.50	717	132,886.80
	2018	188	62,158.93	331	54,098.30	519	116,257.23
	2019	83	27,486.80	338	57,113.80	421	84,600.60
	2020	69	18,011.60	313	45,442.60	382	63,454.20
	2021	78	29,314.70	462	56,210.20	540	85,524.90
	2022 Core	74	22,625.53	326	61,041.50	400	83,667.03
	2022 Sonic	103	3,401.42			103	3,401.42
2023	14	6,256.90	170	29,476.60	184	35,733.50	
Total Hecla		1,121	306,986.95	4,189	551,060.10	5,310	858,047.05

### 7.3 HECLA DRILLING, 2014 TO 2023

In 2014, underground drilling targeted the West Mine with the down plunge extension of the 113 Zone, in the 118, 123 and 124 zones in the Principal area, and a small campaign was conducted on the east extension of the Principal area for the 140 Zone. Surface drilling targeted the Principal area east extension with the 134 and 140 zones. Definition and infill drilling was entirely from underground to drill the extension of known Mineral Reserves and Mineral Resources near the West Mine in the 113, 118, 123, and 124 zones.

In 2015, drilling targeted the 118, 123, 124 and Lower Inter zones in the West Mine from underground and surface. Drilling continued to target the East Mine potential for the 144 and 157 zones and to test the down plunge of the 148 and 160 zones. Infill and definition drilling were conducted mostly in the Principal area on the 118, 123 and 124 zones.

In 2016, the surface drilling program continued to target the West Mine with the 109 and 113 zones below the current infrastructure. From underground the extension of the Lower Principal was targeted to the 117 Zone. Infill and definition drilling were primarily carried out in the Principal area including the 118, 123, and 124 zones.

The 2017 program was the largest drilling campaign since 2006. Drilling targeted the 123 and 124 zones from underground and surface. A surface drilling campaign was completed at the 134 Zone to test the open pit potential

east of the Principal area. The potential for open pit resources near the West Mine was tested by drilling the Northwest and Southwest zones in the crown pillar. Infill and definition drilling from surface targeted the EMCP Pit, 134 Zone, and 160 Zone preliminary pit. Underground infill and definition drilling were completed at the Principal area to extend the Mineral Resources and Mineral Reserves for the 118, 123, and 124 zones.

In 2018, drilling covered the West Mine and the East Mine to evaluate both surface and underground targets. Surface drilling targeted the down plunge of the 134 Zone under the preliminary pit. Surface drilling also targeted the east extension for underground potential of the 124 Zone. Drilling from surface tested the west extension of the 146 and 148 zones for underground potential. A combination of definition and exploration drilling targeted the WMCP to better define the pit potential. Underground drilling continued in the Lower Principal area from the 990m level to test the down plunge mineralization of the 118 and 123 zones. Infill and definition drilling from surface were primarily designed to define an open pit in the EMCP Pit, F134 Pit, F160 Pit, and WMCP Pit areas. Underground infill and definition drilling were carried out in the Principal area to evaluate the 118, 123, and 124 zones. In 2018 underground definition drilling commenced in the East Mine from the 300m level under the 160 Zone preliminary pit to test the down plunge mineralization for underground mining potential.

In 2019, surface drilling targeted the eastern portion of the Principal Mine within the 128 Zone, specifically the high-grade plunge of known lenses, and aimed to further define the 160 Zone lenses within the pit shell. Furthermore, surface drilling targeted the continuation of those lenses under the pit shell. In the North Domain, the surface campaign aimed to investigate the eastern potential of the 160 Zone in the East Mine, and the extension of the 157 Zone to the south of Casa Berardi Fault.

Underground drilling pursued five targets: 1) the eastern extensions of the 128 Zone from the 290m level, 2) the western extension of the 118 Zone from the 990m level exploration drift, 3) the 113 Zone from the 1,010m level, 4) the 152 Zone from the 455m level ramp in the East Mine and 5) the 148 Zone below current infrastructures from the 485m level in the East Mine.

In 2020, surface drilling was conducted to help determine the near surface eastern extent of the F160 Pit (159-05 lens), thus enabling the engineers to determine a new location for the creek to flow around the potential pit.

Underground drilling actively pursued the 123 Zone below current infrastructure from the 1,070m level, the 128 Zone from the 490m level in the Principal Mine area, and the 148 Zone below current infrastructures from the 485m level in the East Mine.

In 2021, surface drilling targeted the different lenses located outside of the WMCP pit shell, the down trend extension of the 105 Zone in the West Mine, the east and west extension of the 128 Zone, the downward plunge of the 139 lens, and the extension of the 159 and 160 lenses within the F160 pit shell.

Underground drilling aimed to investigate many zones of the Casa Berardi Mine from west to east, targeting: 1) the upper portion of the 113 Zone from the 990m level, 2) the downward plunge of the lower 123 Zone from the 1,070m level, 3) the upward plunge of the 123-01 lens, and 4) the downward extension of the 148-01 lens.

65  
65

In 2022, surface holes were drilled to test for continuity of the 152 Zone and the extension of the known lens of the 134 Zone outside the pit shell above 518m vertical depth. Drilling also targeted the 124 Zone, and the 104, 105 and Lower Inter Zone package to test the continuity near infrastructure between 607m and 1,067m vertical depth.

The underground drilling focused on three main zones. The 123 Zone in the Principal Mine was drilled to test the downward and eastern extensions of the 123-02 lens. Drilling also targeted the 148 Zone to test for extensions at depth and laterally, both east and west, and the 118 Zone to test the continuity at depth.

In 2023, surface drilling targeted the 134 and 139 Zones at depth to test the continuity of mineralization. One hole was drilled to determine the nature and extent of stratigraphic units in the area. The 154 Zone was also targeted to confirm the orientation and dip of the zone. Lastly, the 123 Zone was drilled to generate new resources in possible extensions laterally and at depth near current infrastructure.

Underground drilling targeted the east extension of the 123 Zone, the 118 Zone to test for continuity at depth, and north of the 118 Zone to test anomalous gold mineralization in the iron formation. The Lower Inter Zone was also drilled to expand resources near current infrastructure.

### 7.3.1 HECLA DRILLING PROTOCOLS

Hecla has stated that when the Casa Berardi project was acquired from Aurizon in 2013, most of the Aurizon mine staff were retained, and general procedures and protocols at the mine site were maintained. Because significant changes during transfer of the operating mine were minimal, Hecla's statement to RESPEC that drilling protocols followed by Aurizon were the same or similar to those currently employed by Hecla is reasonable, although documentation of drilling procedures prior to 2014 were not available. The following discussion therefore applies to both Aurizon and Hecla drilling programs completed since 2006. It should be noted that during the 2023 site visit, RESPEC was able to observe and confirm some parts of the procedures and protocols but can only infer that the various practices as described below have been followed by Aurizon and Hecla since 2006.

Casa Berardi exploration drilling has had a wide range of purposes within the extensive property and is classified into four categories:

- / Surface and underground exploration drilling, which is performed inside the mining leases along the strike of known gold occurrences, was conducted to build future Inferred Mineral Resources;
- / Regional exploration outside the mining leases was conducted to target favorable structural and alteration features along the Casa Berardi Deformation Zone;
- / Additionally, conversion drilling, which includes definition and infill drilling, is conducted mainly at the mine site (surface and underground) within the mine areas and was designed to upgrade the classification of Inferred Mineral Resources to Indicated and Measured for future reserve potential; and
- / Condemnation drill holes have also been completed to test and condemn the locations of planned infrastructure of the Casa Berardi Property.

Drill holes are planned (azimuth, dip, length) by Hecla geologists on vertical cross-sections and on longitudinal sections. Drill lines are marked underground (front site and back site) by the mine surveyors. Prior to drilling, a technician verifies the drill rig alignment on hole set up. On the surface, drill collars are spotted with the use of

66  
66

surveying equipment. Typically, two front sites, identified with wood pickets, are used to align the drill rig. Down-hole deviations (azimuth and dip) are measured with Reflex instruments approximately every 50m along the hole. Complementary with the Reflex survey, a North Seeking Gyro is used when drilling is located near magnetic rock. This type of survey is not impacted by magnetism and can provide accuracy in measuring the down-hole drill traces. Once a hole is completed, collars coordinates are surveyed by Hecla mine surveyors and geology technicians. All drill holes on site are abandoned by filling the entire hole with cement, or as completely as down-hole conditions allow.

Surface diamond drilling is generally performed during winter to take advantage of the frozen ground (January to April), and to minimize the environmental impacts of the drilling. The drill rigs are moved on ice roads using heavy equipment and snowmobiles and are set up on winterized drill pads. Surface drilling is limited during the summer season to minimize the footprint of gravel roads constructed to access the drilling pads. Underground drilling from the West Mine and East Mine are conducted from drill bays, haulage drifts, or other accessible drilling platforms. The underground drills are moved with heavy underground equipment and access to the drill is via service truck or tractor. Orbit Garant Drilling based in Val-d'Or, Québec provided drilling services for both underground and surface campaigns. Typically, NQ diameter drill core is obtained from exploration, infill, and definition drill holes. The drill core diameter is reduced to BQ if difficult ground conditions are intersected.

Once retrieved from the core barrel, the core is placed in sequential order in core boxes labelled with the hole number. The boundaries of each run, usually three meters, are identified by wood blocks on which the interval depths are marked. Missing (none recovered) core is identified by a wood stake indicating the location and length of the missing section. At the end of each shift, core boxes are transported by the drillers' foreman to the secure core processing facility (core shack) on the surface within the Casa Berardi site. The Casa Berardi site is not completely fenced, but the only road access is through security at the gated front entrance. A Hecla technician sorts and opens the core boxes to evaluate the core quality and measure the accumulated core length. Each core box is photographed and linked with the log database. An aluminum tag etched with the hole number, box, and the contained "from-to" interval is fixed to each core box. After labeling, the Hecla geologist enters a detailed log description of the holes into the Log Chief database.

The geology and assay data obtained from drill samples and recorded in the drill logs, core photographs, and in the various databases are described in Section 11.0. Their usage in Mineral Resource estimation is described as well.

## 7.4 HYDROGEOLOGY DRILL HOLES

Between 2022 and 2023, six hydrogeological drill holes were completed in the 160 Zone (Table 7-2). Piezometers were installed to measure underground water pressure. An analysis and brief discussion of the hydrogeology characterization related to open pit designs is presented in Section 13.4.

**Table 7-2. Hydrogeological Drill Holes Between 2022 & 2023**

Drill Hole Name	Zone	Core Size	Length (m)
F160-PZ-22-01	160	NQ	25.4

67  
67

F160-PZ-22-02	160	NQ	25.6
F160-PZ-22-03	160	NQ	30.6
F160-PZ-22-04	160	NQ	3.8
F160-PZ-22-05	160	NQ	33.76
F160-PZ-22-06	160	NQ	21.3

## 7.5 GEOTECHNICAL DRILL HOLES

In 2022 and 2023, eight geotechnical holes were drilled to assess ground conditions in the 148 Zone and the 160 open pit Table 7-3. Core recoveries and rock quality designation (RQD) were measured, and the mean RQD was approximately 82.5%. The objective of the 2022 drilling was to investigate a small collapse in the East Mine and to determine if the stopes were stable enough for mining to continue. In 2023, the objective was to test the slope stability of the highwall in the open pit.

68  
68

RSI-M0206.22001

**Table STYLEREF 1 \s 7-. Geotechnical Drill Holes from 2022-2023**

	<b>Drill Hole No.</b>	<b>Zone</b>	<b>RQD (%)</b>	<b>Core Diameter</b>	<b>Length (m)</b>
Underground	CBE-0415-001	148	78.89	NQ	78
	CBE-0415-002	148	82.99	NQ	57.9
	CBE-0415-003	148	81.44	NQ	65
	CBE-0415-004	148	81.44	NQ	62.8
	CBE-0415-005	148	74.03	NQ	68.5
	CBE-0415-006	148	87.33	NQ	68.5
	CBE-0415-007	148	75.97	NQ	73
	ING-001	160 open pit	97.59	NQ	38.5

## 7.6 COMMENTS ON DRILLING

RESPEC notes that the quantity and quality of the logging, geotechnical, collar, and down-hole survey data collected in the exploration and infill drill programs are sufficient to support Mineral Resource and Mineral Reserve estimation and makes the following comments:

- / Core logging performed by Hecla staff follows generally accepted industry standards for exploration and delineation of gold deposits;
- / Collar coordinate and down-hole surveys for Hecla core holes have been performed using standard methodologies and instrumentation;
- / Geotechnical logging of drill core meets industry standards, and can be used to support geotechnical studies planned for open pit and underground mining operations;
- / Because mine staff and mining procedures and protocols were essentially unchanged following Hecla's acquisition of the Casa Berardi project, it can be reasonably expected as Hecla has stated that drilling and sample collection protocols followed prior to the acquisition were similar to those currently employed by Hecla; and
- / No significant factors were identified regarding drilling and data collection protocols from the Aurizon or Hecla programs that could adversely affect Mineral Resource or Mineral Reserve estimates.

## 8.0 SAMPLE PREPARATION, ANALYSES, AND SECURITY

Hecla has stated that when the Casa Berardi project was acquired from Aurizon in 2013, most of the Aurizon mine staff were retained, and general procedures and protocols at the mine site were maintained. Because significant changes during transfer of the operating mine were minimal, Hecla's statement to RESPEC that sample preparation, laboratory analyses, security, and QA/QC protocols followed by Aurizon were the same or similar to those employed by Hecla is reasonable, although documentation of procedures prior to 2014 were not available. The following discussion therefore applies to both Aurizon and Hecla drilling programs completed since 2006. It should be noted that during the 2023 site visit, RESPEC was able to observe and confirm some parts of the procedures and protocols, but can only infer that the various practices that are summarized in Sections 5.2.1 and 7.3 have been followed by Aurizon and Hecla since 2006.

### 8.1 DRILL SAMPLE HANDLING PROCEDURES AND SAMPLE SECURITY

Drill core from Hecla exploration, definition, and infill programs is handled and sampled by contractor technicians under the supervision of Hecla staff. Core is logged by Hecla geologists at the secure core shack located within the Casa Berardi mine site. Access to the core shack is restricted to geology personnel who use magnetic key cards. The mine site is not completely fenced, but the only road access is through security at the gated front entrance. The core is logged and sampled, then stored in the core shack until sufficient samples have been accumulated for shipment from the mine site to the external laboratory for analysis. The transport vehicle is provided by the external laboratory.

Upon receipt of the core boxes from the contractor technicians, core boxes are placed on tables and sorted. Core is washed and verified for length accuracy, then RQD's and core recoveries are measured in all surface and underground holes prior to logging. In general, RQD measurements are carried out over three-meter lengths, with shorter lengths used in areas of bad ground. This allows for better interpretations regarding in-situ ground conditions. For a certain period between 2008 and 2010, RQD measurements were carried out over much longer lengths with some measurements over 20m. Such measurements over long lengths are not very useful for rock mechanics purposes to identify zones of bad ground conditions and this practice was discontinued. The entire core from underground drilling is photographed and systematic photography of core from surface drilling commenced in 2008.

The core recovery averages nearly 100%, with the exception of short intervals within fault zones or highly deformed mudrock. Such intervals are generally marked during drilling and later checked by Hecla geology personnel for depth accuracy and missing sections.

Following geotechnical logging, geological and structural data are described by geologists and entered into a digital logging package. Drill-hole logs summarize hole parameters, core descriptions, and sampling intervals. Core logging is carried out in French. Before sampling, the drill core is stored within the secure core shack. After sampling, the remaining core is taken to other storage facilities on the mine site and stored primarily on core racks.

70  
70

### 8.1.1 CORE SAMPLING

Sample selection for assaying is determined visually by Hecla's geologists based on rock type, alteration, quartz veins, and mineralization. Sample intervals are identified, and commercially printed bar-coded sample tags are placed under the core in the core boxes at the end of each sample. The beginning and end of each sample are also marked on the core with individual sample lengths varying from 0.4m to 1.5m. Most of the samples are about one meter in length. The geologist marks a reference line along the length of the core length, then the core is sent to a technician to be cut along the reference line for sampling.

In the case of exploration and definition holes, the selected samples are sawn into two halves along the reference line by the core shack technician using an electrical core saw equipped with a diamond-impregnated blade. One half is placed in a plastic bag with the corresponding tag number. The other half core is returned to the core box, with the corresponding sample tag stapled to the core box at the beginning of the sampled interval. The technician consistently samples from the same side of reference line and replaces the other side. The core saw and metallic pans are cleaned between samples. In the case of infill drill holes, the core is not split, and the entire sample is submitted for assaying. Bags are folded and sealed to prevent spillage during transportation to the laboratories. Each batch of three to five samples is placed in a plastic container for transportation to the mine laboratory or in a burlap bag for transportation to an external laboratory.

All samples remain within the mine site until they are processed by the mine lab or picked up by the external lab. For samples shipped to an external lab, bagged samples are transported by pick-up truck from the core processing facilities to the sample receiving facilities of the mine laboratory for temporary storage. Samples are sent via pick-up truck to external laboratories. Chain-of-custody procedures consist of sample submittal forms that are sent with sample shipments, which allows for shipment tracking to ensure that all samples are received by the laboratory.

Lithochemical data is collected with exploration drilling for rock discrimination. The sampling consists of selecting a representative 40cm core sample systematically every 30m to 50m or at lithological changes, until a representative compilation of a given unit is collected.

### 8.1.2 UNDERGROUND DEVELOPMENT HEADING SAMPLES

At the mine, chip samples are taken to determine the gold value over a given interval of rock to align development and exploration activities, estimate the value of mineralized lenses, and to reconcile mining with mill production. Along the walls of draw-points, chip samples are taken perpendicular to the stratigraphic and structural trend of the mineralized body. Prior to chip sampling, the intervals to be sampled are geologically mapped in order to delineate changes in lithology, mineralization, alteration, and structure.

Chip samples are localized by hip-chain from surveyed anchor points in the mine. The intervals are typically one meter in length, though they may range from a minimum of 50cm to a maximum of 1.5m to respect geological constraints. The beginning and end of the interval are marked at chest-height using yellow spray paint and are then plotted on the geological map.

Plastic sample bags used to collect the chip samples are prepared with a sample tag and placed at each interval. The bags are sealed for transport to prevent contamination. The sample tag is a scannable, water-resistant tag that is taken from a booklet containing the sample number, the date and location of the sample, the sampler's name, and other notes and sketches.

71  
71

## 8.2 SAMPLE PREPARATION AND ANALYSIS

Since 2013, Hecla has primarily used Swastika Laboratories Ltd. (Swastika) in the town of Swastika, Ontario and the Casa Berardi mine laboratory (Labomine) for preparation and analysis of all exploration and delineation drilling samples. Check assay samples are sent to ALS Geochemistry (ALS) laboratories in Val d'Or, Québec. MSALABS was used for a brief period in 2022. Prior to 2013, Aurizon used a variety of external laboratories in addition to the mine laboratory, including SGS Canada Inc. (SGS) in Rouyn-Noranda, Québec, Techni-Lab S G B Abitibi Inc. (Techni-Lab) in Ste Germaine, Québec, and Laboratory Expert Inc. (Lab-Expert) laboratory in Rouyn-Noranda, Québec. Swastika, ALS, MSALABS, SGS, Techni-Lab, and Lab-Expert are or were commercial analytical laboratories independent of Hecla. Over time, core samples from exploration and delineation drilling have been assayed by the various labs as follows:

Aurizon, 2004 to 2013:

2004, 2005 and part of 2006: SGS.

2006: Mine laboratory, SGS, Techni-Lab, and Swastika.

2007: Mine laboratory and Techni-Lab.

2008: Mine laboratory and Lab-Expert.

2009 to 2013: Mine laboratory and Swastika.

Hecla, 2013 to 2023:

2013 to 2022: Mine laboratory and Swastika.

2022: Mine laboratory, Swastika and MSALABS.

2023: Mine laboratory and Swastika.

All samples for lithogeochemical analysis are sent to ALS. Swastika and ALS have been accredited by the Canadian Association for Laboratory Accreditation Inc. for meeting the requirements of ISO/IEC 17025:2005 for various gold assay protocols. The accreditation status of SGS, Techni-Lab, Lab-Expert and MSALABS at the time of their respective assay work for Hecla is not known. No information is available for the laboratories used prior to 2004.

### 8.2.1 MINE LABORATORY

The laboratory at the mine is used to assay most of the drilling samples generated for underground production headings, and infill and definition drilling. Run-of-mine samples for the open pits have also been sent to the mine laboratory for assay. Sample preparation and gold analysis is completed on site by Hecla staff. The mine laboratory is not independent of Hecla and is not ISO certified.

Upon arrival at the mine laboratory, samples are sorted and checked against the sample shipment list. All samples are dried in the oven for several hours until dry. All whole core samples, which weigh approximately 10kg each, are entirely crushed to 80% passing ( $P_{80}$ ) 6.3mm in a jaw crusher. The jaws are cleaned with compressed air and flushed with barren core after each sample. The material exiting the jaw crusher is transported by a conveyor belt onto a rotary splitter. Approximately 200g to 250g of split material is crushed to a 95% minus 150-mesh or 85% minus 200-mesh sample pulp using a ring-and-puck pulverizer. The remaining coarse reject material is collected into the original plastic sample bag, placed with their respective pulps in a container, and stored in a warehouse facility at the mill.

The pulp is laid down on a rubber mat and homogenized. A 15g sub-sample is then collected, weighed, and analyzed by fire assay with an atomic absorption spectrometer (AAS) finish. All results, reported in grams per tonne, are sent

72  
72

electronically to Hecla. Final assay results are stored digitally, and paper copies are generated or stored by the mine laboratory.

### 8.2.2 SWASTIKA

Exploration drilling samples from underground and surface are sent to Swastika, which is an external, independent laboratory. Samples are transported from the mine lab via truck by Swastika.

Sample submissions are divided into work orders that contain the batch number, sample numbers, date, weight, elements, and analyses requested. Each batch is made up of 63 samples, which comprise 52 Hecla samples and 11 laboratory quality control samples. Each batch starts with a blank and a standard, which is followed by 19 Hecla samples. The pattern is repeated until a total of 63 samples are in the batch. Pulp rechecks are taken by the lab every ten samples and recorded in a separate column on the assay certificate. A bar coding system is used to track samples and sample receipt reconciliation notices are transmitted by email.

Samples are dried in an oven at 80°C and then are entirely crushed to P<sub>80</sub> 1.7mm with a jaw crusher and split with a rotary splitter. Jaws are cleaned with compressed air and flushed with barren limestone after each sample. Approximately one kilogram of the jaw-crushed sample is entirely pulverized to 90% minus 107µm in a ring-and-puck pulverizer. All pulverized material is placed on a rubber mat, homogenized, and transferred into disposable brown paper bags for weighing. Pulverizer bowls and rings are cleaned with compressed air and flushed with barren silica sand after each sample. A 30g aliquot of pulverized material is split out and analyzed by fire assay with an AAS finish. A second fire assay analysis is completed with a gravimetric finish for samples with gold results above 10g/t Au.

All of the remaining pulverized pulp material is returned to Casa Berardi for storage and quality control. Approximately 5% of each sample of coarse reject material is returned to the mine site and stored for future use. The remaining reject material is discarded by Swastika.

## 8.3 HISTORICAL QA/QC PROGRAMS

RESPEC is not aware of the methods and procedures used by historical operators prior to Aurizon at Casa Berardi for quality assurance/ quality control (QA/QC). RESPEC has obtained and reviewed the results of the historical QA/QC samples that were analyzed commencing in about 2006.

## 8.4 AURIZON/HECLA QA/QC PROGRAMS

As previously noted, Hecla has stated that when the Casa Berardi project was acquired from Aurizon in 2013, most of the Aurizon mine staff were retained, and general procedures and protocols at the mine site were maintained. Because significant changes during transfer of the operating mine were minimal, RESPEC considers that the QA/QC protocols followed by Aurizon were the same or similar to those employed by Hecla. Much of the following discussion combines the analysis and evaluation of results from both Aurizon and Hecla QA/QC programs.

73  
73

#### 8.4.1 QA/QC DATABASE

Hecla's QA/QC database contains certificate numbers, dates, sample numbers, original assays, duplicate assays, standard assays, standard types, and laboratories used for assaying. No QA/QC data from drilling and assaying programs conducted by operators prior to Aurizon at Casa Berardi was available for review by RESPEC.

#### 8.4.2 QA/QC PROTOCOLS

Hecla's QA/QC protocols included the insertion of standards (4%) and blanks (5%) into the sample stream for all samples sent to the primary laboratories (Labomine and Swastika). Pulp (5%) and coarse reject (5%) splits from both Labomine and Swastika laboratories have also been sent to ALS for referee check assays. Aurizon's QA/QC protocols and insertion rates are presumed to have been similar.

A CRM was inserted systematically at every 25<sup>th</sup> sample. Several standards with a range of target values were obtained from OREAS and Rocklabs. Coarse blanks are inserted at approximately every 20<sup>th</sup> sample by the geologist. Local blanks consisting of exploration core from barren material that has been previously assayed was used prior to 2021. Certified blanks consisting of dolomite were obtained from a commercial source and have been used since 2021.

Approximately 4% of pulps are split and analyzed at the mine laboratory and at Swastika as part of their internal QA/QC programs. In addition to the regular pulp duplicates, if an assay exceeds 10.0g/t Au, an automatic recheck is performed.

#### 8.4.3 PULP DUPLICATES

Between 2009 and 2023, a total of 39,967 pulp duplicate samples were split and analyzed as part of the primary laboratories internal QA/QC programs (Table 8-1). The relative differences in sample pairs range from 0% to 20%, which indicates a reasonable variability expected in pulp rechecks for gold deposits. The average relative difference over the 15-year period is <1%, which suggests no significant bias over time. However, assay variability, which is a measure of the heterogeneity of gold in the deposit, and the bias that occurs for any given drilling campaign, cannot be determined from the averaged data in Table 8-1.

Table 8-1 presents the results of the duplicate versus original assay comparisons carried out over the period from 2009 to 2023. The differences between the mean grade of original assays and the mean grade of duplicate assays is generally less than 3.1% for any given year, with the exception of the Swastika lab comparisons in 2017 (mean of duplicates is greater than mean of original pulp assays by 20%) and 2020 (mean of original pulp assays is greater than mean of duplicates by 9.07%). The cause of the relatively extreme bias at the Swastika lab during those years is not known.

In 2023, 1,450 duplicate pulps were analyzed. 1,074 samples, or 74% of the original samples submitted were mineralized at or greater than 0.1g/t Au. Average bias was within 3.1% for the two labs.

Table STYLEREF 1 \s 8-. Pulp Duplicate Summary from 2009 to 2023

Year	Original Laboratory	Number of Duplicates	Mean Grade of Original Assays (g/t Au)	Mean Grade of Duplicates Assays (g/t Au)	Difference (%)
2009	Mine	309	6.29	6.26	(0.5)
	Swastika	958	5.88	5.79	(1.5)
	ALS	32	6.21	6.17	(0.6)
2010	Mine	965	5.22	5.14	(1.5)
	Swastika	631	2.09	2.11	1
2011	Mine	1,162	5.26	5.29	0.6
	Swastika	1,114	2.48	2.46	(0.8)
2012	Mine	1,707	7.47	7.5	0.4
	Swastika	847	0.561	0.563	0.4
2013	Mine	1,588	6.64	6.6	(0.6)
	Swastika	578	0.341	0.349	2.3
2014	Mine	1,382	6.37	6.38	0.2
	Swastika	1,244	0.994	0.993	(0.1)
2015	Mine	2,045	11.25	11.34	0.8
	Swastika	1,816	0.68	0.69	1.5
2016	Mine	1,827	8.18	8.05	(1.6)
	Swastika	462	0.45	0.45	0
2017	Mine	1,994	5.15	5.14	(0.2)
	Swastika	2,731	1.024	1.228	20
2018	Mine	1,744	4.83	4.75	(1.7)
	Swastika	3,023	0.208	0.208	0
2019	Mine	1,425	5.45	5.48	0.55
	Swastika	2,305	0.305	0.299	(1.97)
2020	Mine	823	2.56	2.56	0.05
	Swastika	1250	0.683	0.621	(9.07)
2021	Mine	525	3.05	3.10	1.63
	Swastika	1,638	0.297	0.299	0.67
2022	Mine	1,089	4.19	4.12	(1.69)
	Swastika	1,303	0.11	0.11	(0.10)
2023	Mine	675	5.66	5.49	(3.08)

	Swastika	775	0.49	0.50	2.18
--	----------	-----	------	------	------

An example of the pulp duplicate comparison is provided in Figure 8-1. The graph depicts the duplicate versus original assays for mine laboratory pulps during the period of 2021 to 2023 and indicates there is no significant bias between the two data sets.

**Figure STYLEREF 1 \s 8-. Mine Laboratory Pulp Duplicate Assays from 2021- 2023**  
(Assays below 120g/t Au)

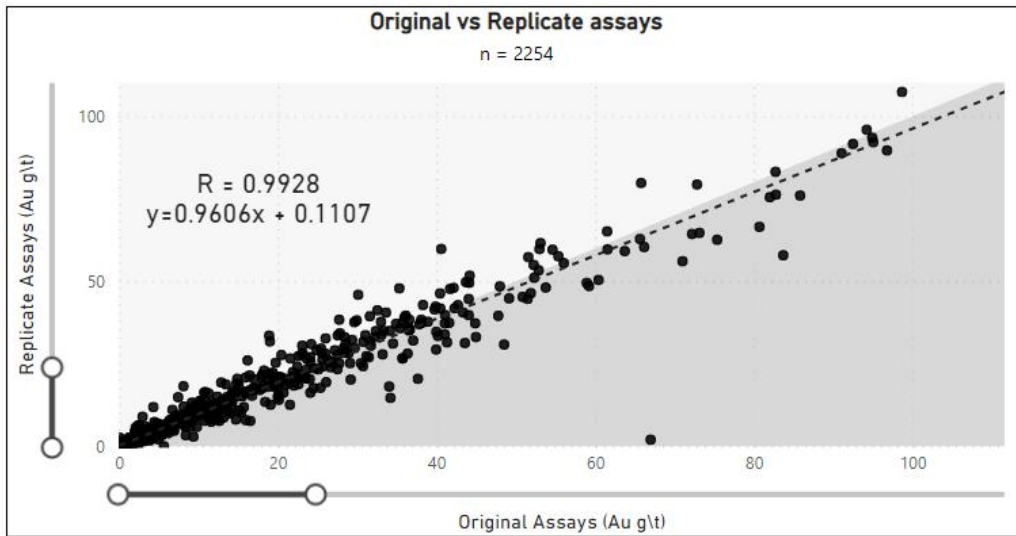

#### 8.4.4 PULP EXTERNAL CHECK ASSAYS

Since early 2009, approximately 5% of original pulps were sent for re-assay at ALS. Since October 2018, the pulps for reanalysis were selectively taken from mineralized zones, generally with grades above 1.0g/t Au, in development drilling. All the laboratories used fire assay with an AAS or gravimetric finish.

A summary of the comparisons between original assays and check assays of the 2009 to 2023 programs is provided in Table 8-2. In nearly all cases, the means of the ALS check assays are higher than the means of the original assays, with three exceptions (Swastika in 2009, 2012 and 2021). The bias is generally less than 5%, but there are a number of years where the bias is between 5% and 16%. The bias indicates that the assays provided by one lab are high or low in the other lab, however, it is not possible to determine which lab or labs are in error based on the check assay data alone. Regardless, the consistent bias with ALS check assays higher than both Swastika and the mine lab should be investigated.

Table STYLEREF 1 \s 8-. External Check Assays from 2009 to 2023

Year	Laboratories	Number of Assays	Mean Grade Original (g/t Au)	Mean Grade Check (g/t Au)	Difference (%)
2009	Mine vs. ALS	534	11.98	12.32	2.8
	Swastika vs. ALS	187	5.3	5.23	(1.4)
2010	Mine vs. ALS	744	9.77	9.97	2.1
	Swastika vs. ALS	87	4.89	5.05	3.2
2011	Mine vs. ALS	918	7.05	7.18	1.8
	Swastika vs. ALS	87	4.89	5.05	3.2
2012	Mine vs. ALS	1,234	6.31	6.57	4.0
	Swastika vs. ALS	61	2.89	2.76	(4.7)
2013	Mine vs. ALS	1,170	6.54	6.6	0.9
	Swastika vs. ALS	50	3.34	3.72	11.4
2014	Mine vs. ALS	1,179	7.63	7.65	0.2
	Swastika vs. ALS	169	2.73	2.86	4.7
2015	Mine vs. ALS	1,471	8.49	8.54	0.6
	Swastika vs. ALS	180	3.49	3.49	0.1
2016	Mine vs. ALS	1,427	7.23	7.33	1.4
	Swastika vs. ALS	68	1.73	1.85	6.9
2017	Mine vs. ALS	1,023	5.31	5.37	1.1
	Swastika vs. ALS	85	1.74	2.02	16.1
2018	Mine vs. ALS	788	5.7	5.8	1.8
	Swastika vs. ALS	653	2.93	3.18	8.5
2019	Mine vs. ALS	943	4.568	4.61	0.9
	Swastika vs. ALS	343	1.73	1.86	7.5
2020	Mine vs. ALS	517	3.79	3.56	6.7
	Swastika vs. ALS	349	3.7	3.76	1.6
2021	Mine vs. ALS	671	7.05	7.18	1.8
	Swastika vs. ALS	40	7.81	7.30	(6.5)
2022	Mine vs. ALS	923	6.02	6.43	6.83
	Swastika vs. ALS	1,384	3.34	3.50	4.89
2023	Mine vs. ALS	601	8.50	9.08	6.81
	Swastika vs. ALS	462	1.22	1.27	3.84

Figure 8-2. presents a scatter plot of the mine laboratory versus ALS check assays on pulps from 2021 to 2023 and Figure 8-3 presents a scatter plot of Swastika original assays versus ALS pulp check assays from the same time period. Both plots confirm the high bias in ALS check assays relative to original Swastika assays indicated by the comparison of mean assays in Table 8-2. Of significance are the large number of check assays with grades of  $\sim 0.02\text{g/t Au}$  for samples with a wide range of original assay values. The opposite is also true for Swastika versus ALS assays (many  $< 0.01\text{g/t Au}$  original values with wide range of check assay values) in Figure 8-3. The cause for this is unknown, but it should be investigated.

78  
78

Figure STYLEREF 1 \s 8-. Mine Laboratory Pulp External Check Assays at ALS (2021-2023)

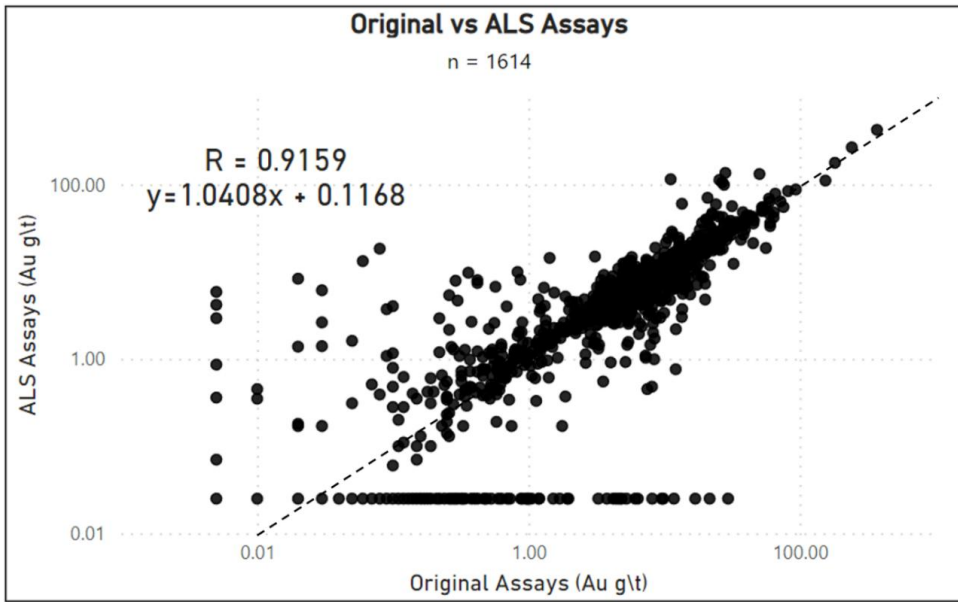
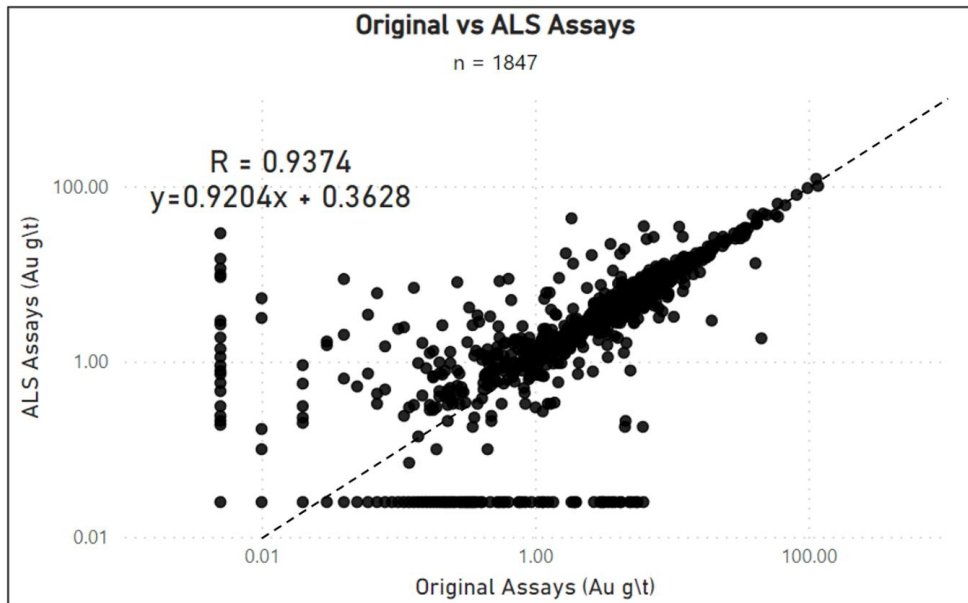

Figure STYLEREF 1 \s 8-. Swastika Pulp External Check Assays at ALS (2021-2023)

79  
79



#### 8.4.5 COARSE REJECT EXTERNAL CHECK ASSAYS

Approximately 5% of original coarse rejects were sent for re-assay at ALS. Sample numbers for re-assays are the same as for original assays. Samples with a grade above 1.0g/t Au were generally selected. New pulps are prepared at the secondary laboratory from original rejects. The ALS annual means are generally higher than the mine and Swastika annual means (Table 8-3) which indicates that ALS gold assays are biased high. As with the pulp check assays, the averaged bias indicates that the assays provided by one lab are high or low in the other lab for any given time period. It is not possible to determine which lab or labs are in error based on the check assay data alone. However, unlike for pulp check assays, the results from coarse reject check assays are inconclusive, because the source of the bias, whether due to sample preparation or analytical differences between the labs, cannot be determined. RESPEC recommends that no further check assays from coarse reject material be conducted.

Table STYLEREF 1 \s 8-. Reject External Check Assays

Year	Laboratories	Number of Assays	Mean Grade Original (g/t Au)	Mean Grade Check (g/t Au)	Difference (%)
2009	Mine vs. ALS	473	6.39	6.35	(0.7)
	Swastika vs. ALS	232	4.79	4.84	1
2010	Mine vs. ALS	708	5.24	5.23	(0.3)
	Swastika vs. ALS	76	2.5	2.78	11.3

80  
80

Year	Laboratories	Number of Assays	Mean Grade Original (g/t Au)	Mean Grade Check (g/t Au)	Difference (%)
2011	Mine vs. ALS	788	5.02	5.26	4.5
	Swastika vs. ALS	72	2.18	2.51	13.2
2012	Mine vs. ALS	1,135	4.95	5.14	3.7
	Swastika vs. ALS	82	2.46	2.5	1.6
2013	Mine vs. ALS	1,103	6.05	6.17	2
	Swastika vs. ALS	45	3.78	4.07	7.7
2014	Mine vs. ALS	1,178	7.49	7.37	(1.6)
	Swastika vs. ALS	163	2.29	2.43	6
2015	Mine vs. ALS	1,473	7.48	7.65	2.3
	Swastika vs. ALS	204	3.82	3.65	(4.5)
2016	Mine vs. ALS	1,347	6.54	6.73	3
	Swastika vs. ALS	293	2.33	2.49	7
2017	Mine vs. ALS	1,055	4.93	5.01	1.6
	Swastika vs. ALS	45	1.92	1.67	(13)
2018	Mine vs. ALS	801	6.04	5.79	(4.0)
	Swastika vs. ALS	430	3.35	3.31	(1.2)
2019	Mine vs. ALS	1,033	6.48	6.35	(2.0)
	Swastika vs. ALS	513	1.08	1.18	9.3
2020	Mine vs. ALS	378	6.89	6.47	(6.1)
	Swastika vs. ALS	339	2.82	2.98	5.7
2021	Mine vs. ALS	601	6.83	6.79	(0.6)
	Swastika vs. ALS	281	4.33	4.6	6.2
2022	Mine vs. ALS	1,054	7.57	8.02	5.96
	Swastika vs. ALS	1,360	2.63	2.66	1.40
2023	Mine vs. ALS	726	8.49	8.91	4.99
	Swastika vs. ALS	4	1.41	4.76	238.52
	MSA Labs vs. ALS	70	0.49	0.41	(17.25)

#### 8.4.6 CERTIFIED REFERENCE MATERIALS

Example charts for the CRM “OREAS 235” is shown in Figure 8-4 and Figure 8-5. All assays for each CRM are individually plotted, separately by laboratory, and evaluated monthly for bias relative to the certified expected values (Exp line on the chart, also called target or expected value), and CRM failures defined as assays above and below the

3-standard deviation threshold lines (+3STD and -3STD). For the year 2023 at Labomine, there were a total of four CRM assays that were below the 3-standard deviation limit, which yields a failure rate of 3.4%. However, the primary issue appears to be a low bias demonstrated by the calculated mean of the CRM assay data, which suggests that the mine lab is assaying low on a consistent basis. With no bias, it is probable that none of the CRM assays would have been categorized as failures. The laboratory should be notified immediately when failures occur, and consistent bias as demonstrated.

82  
82

RSI-M0206.22001

---

Figure STYLEREF 1 vs 8-. Plot of 2023 CRM Assays from the Mine Lab for OREAS 235

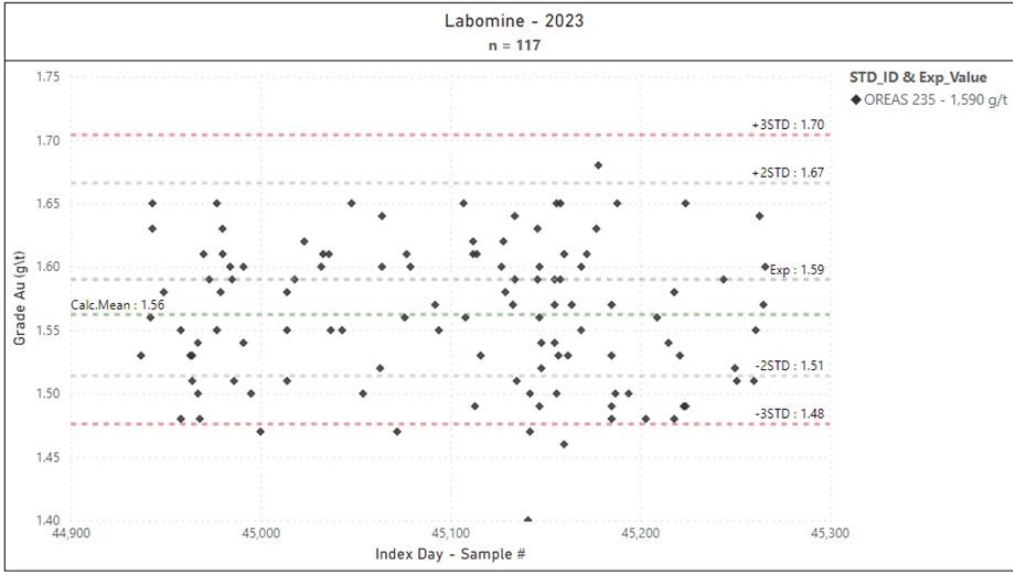

There is no bias, and no CRM assay values that exceed the 3-standard deviation threshold shown on the chart for 2023 Swastika CRM assays of OREAS 235. In fact, no values are outside the 2-standard deviation lines. Less variability in CRM assays is indicated for Swastika compared to the mine lab.

83  
83

Figure STYLEREF 1 \s 8-. Plot of 2023 CRM Assays from Swastika for OREAS 235

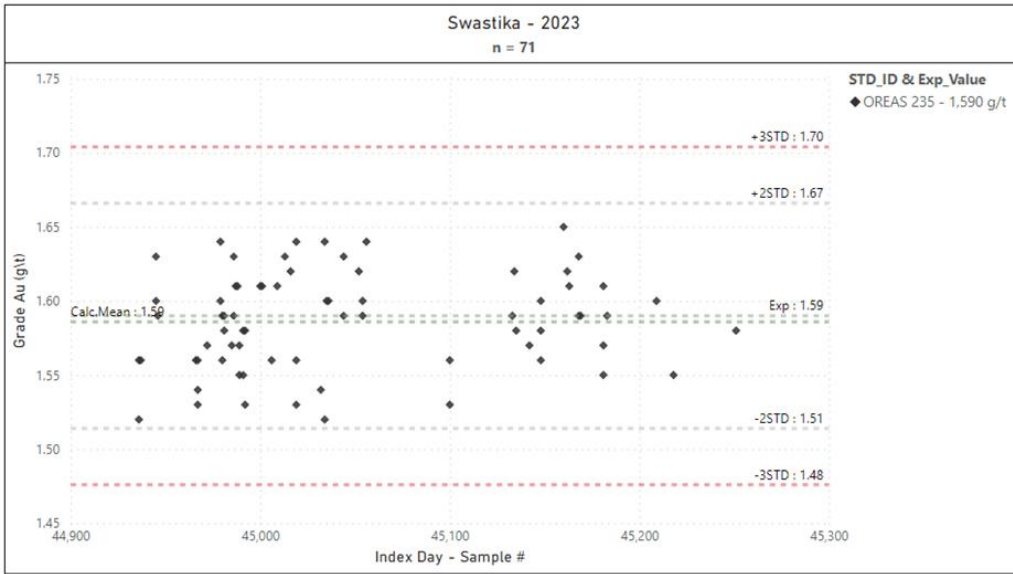

When failures occurred, the respective assay batch was investigated and re-assayed if associated with mineralized intervals. Some CRM failures were suspected to be due to mis-labeling of CRMs, although this cannot be definitively determined. The original or re-assays were incorporated into the database, depending on the results of the investigations. RESPEC recommends continued investigation and re-assaying whenever CRM assays exceed the 3-standard deviation threshold, and the implementation of procedures that will help reduce CRM mislabeling or swaps.

Standards assayed at both labs from 2006 to 2023 at the mine and Swastika labs were plotted together in Figure 8-6 to show any variation in distribution over time for all CRMs. The certified target values and 3-standard deviation limits are not included on the chart, so bias relative to the target value and values that exceed the 3-standard deviation thresholds cannot be ascertained. There are a number of errant values between the data sets that would obviously qualify as failures. Hecla has indicated that assays associated with these and any other failures would have been investigated and re-assayed as warranted. Some could be due to mis-labeled CRMs, although this cannot be definitively determined in any given case. There is some CRM assay drift over time noted in a few data sets (e.g. the light blue and green data sets in the upper right corner of the chart).

Figure STYLEREF 1 \s 8-. Plots of All CRM Assay Results from 2006 to 2023

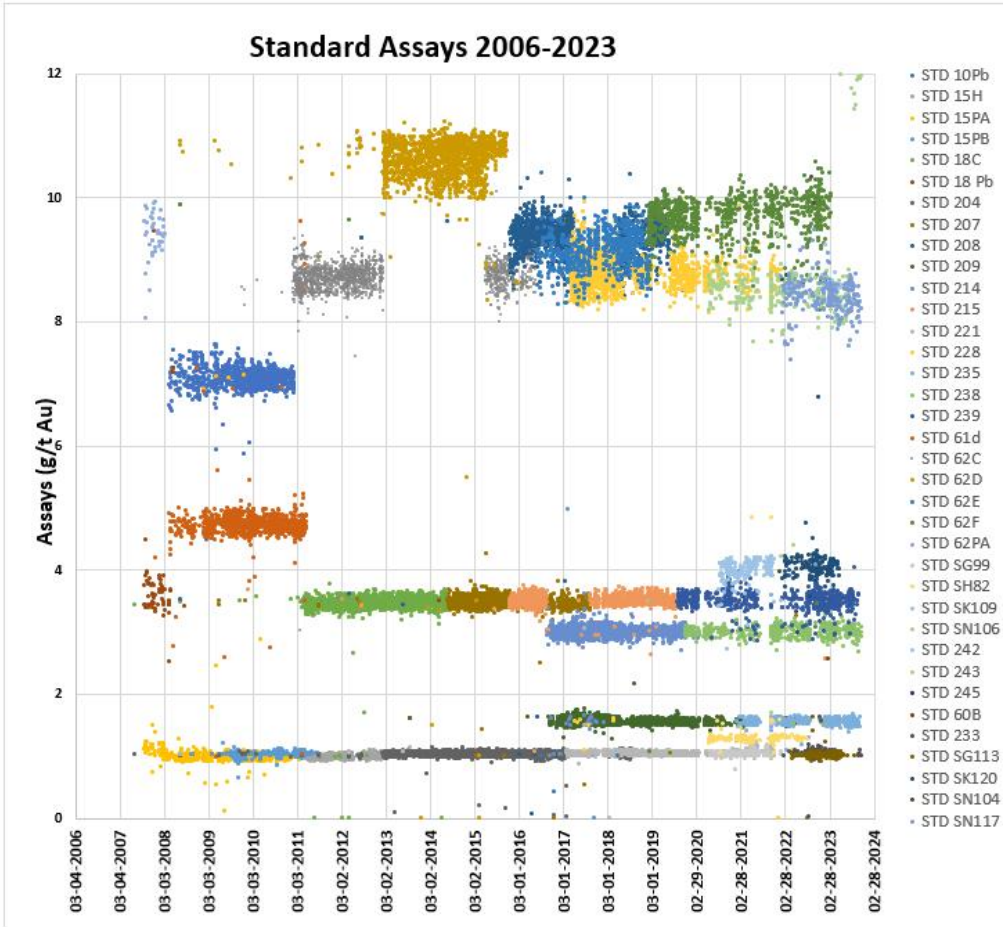

Table 8-4 summarizes the results of the assays of CRMs sent to the various laboratories used from 2004 to 2023. Overall, the CRMs represent approximately 5.6% of the 2005 to 2023 sample database. The average differences between the measured value and the true or expected value of the CRMs are shown. Most of the differences between the expected values and the mean of the CRM assays are within plus or minus a few percent, and the larger differences are generally related to small populations.

Table STYLEREF 1 \s 8-. CRM Assay Results

Standard #	Nominal Value $\pm$ 1 Standard Deviation	Laboratory	Year	Number of CRM Assays	Average	Difference (%)
6Pa	1.65 $\pm$ 0.04	SGS	2004	6	1.37	-17.1
6Pb	1.422 $\pm$ 0.026	SGS	2004	72	1.39	-2.2
			2005	43	1.53	7.8
7Pa	3.00 $\pm$ 0.06	SGS	2004	95	2.95	-1.5
			2005	32	2.97	-0.9
10Pb	7.15 $\pm$ 0.11	Mine	2008	74	6.97	-2.5
			2009	217	7.08	-1
			2010	367	7.08	-1
			2011	55	7.06	-1.3
		Swastika	2009	117	7.21	0.8
			2010	173	7.13	-0.3
			2011	25	7.13	-0.3
15H	1.019 $\pm$ 0.007	Mine	2011	226	0.99	-2.9
			2012	459	1.01	-1
			2013	104	1.02	0.1
		Swastika	2011	51	1	-2
			2012	115	1.01	-1
			2013	18	1	-1.9
15Pa	1.02 $\pm$ 0.02	Lab-Expert	2008	16	1.22	19.5
		Mine	2007	61	1.05	3.2
			2008	130	1.01	-1.2
			2009	181	1.01	-0.7
			2010	275	1	-2
			2011	95	1.01	-0.9
		Swastika	2009	86	1.01	-1.2
			2010	163	0.99	-2.9
2011	24		1.01	-0.9		
15Pb	1.06 $\pm$ 0.02	Mine	2007	4	0.95	-10.4
			2010	81	1.05	-0.9

Standard #	Nominal Value $\pm$ 1 Standard Deviation	Laboratory	Year	Number of CRM Assays	Average	Difference (%)
		Swastika	2010	48	1.07	1.9
18C	3.52 $\pm$ 0.05	Mine	2011	269	3.44	-2.3
			2012	619	3.48	-1.1
			2013	502	3.48	-1.1
		Mine	2014	249	3.48	1.21
		Swastika	2011	74	3.51	-0.1
			2012	142	3.46	-1.7
			2013	87	3.51	-0.3
			2014	79	3.48	1.21
18Pa	3.36 $\pm$ 0.05	Mine	2006	116	3.33	-0.8
			2007	33	3.33	-0.8
		SGS	2004	62	3.27	-2.7
			2005	61	3.11	-7.5
			2006	39	3.12	-7.2
18Pb	3.63 $\pm$ 0.3	Swastika	2006	27	3.63	7.9
		Techni-Lab	2006	78	3.3	-1.8
		Lab-Expert	2008	3	3.79	4.5
		Mine	2007	99	3.56	-2
			2008	28	3.45	-4.8
50P	0.727 $\pm$ 0.021	SGS	2004	110	0.73	0.5
			2005	72	0.77	6.5
			2006	49	0.79	8.4
		Swastika	2006	7	0.72	-0.6
		Techni-Lab	2006	49	0.77	6.5
51P	0.430 $\pm$ 0.013	Mine	2006	138	0.48	10.6
			2007	89	0.45	3.9
		Techni-Lab	2006	16	0.52	21.8
52P	0.183 $\pm$ 0.07	Mine	2007	1	0.44	140.4
		SGS	2005			
			2006	3	0.22	18.4
		Swastika	2006	1	0.21	12.9

Standard #	Nominal Value $\pm$ 1 Standard Deviation	Laboratory	Year	Number of CRM Assays	Average	Difference (%)
		Techni-Lab	2006	3	0.2	9.3
60B	2.570 $\pm$ 0.11	Mine	2023	1	2.58	0.39
61D	4.76 $\pm$ 0.07	Mine	2008	67	4.64	-2.4
			2009	180	4.74	-0.4
		Swastika	2010	394	4.73	-0.6
			2011	207	4.67	-1.9
61Pa	4.46 $\pm$ 0.08	SGS	2004	12	3.72	-16.6
			2005	23	4.25	-4.8
62C	8.79 $\pm$ 0.10	Mine	2011	407	8.63	-1.8
			2012	482	8.72	-0.8
			2013	63	8.78	-0.1
			2015	216	8.73	0.68
			2017	1	3.02	191.06
		Swastika	2011	125	8.93	1.6
			2012	128	8.79	0.1
			2015	39	8.67	1.35
62D	10.50 $\pm$ 0.33	Mine	2013	341	10.56	0.6
			2014	379	10.54	-0.41
			2015	297	10.55	-0.52
		Swastika	2013	86	10.91	3.9
			2014	151	10.83	-3.01
			2015	225	10.83	-3.08
62E	9.13 $\pm$ 0.41	Swastika	2017	204	9.04	0.96
			2018	344	9.25	-1.27
			2019	35	8.95	-1.9
62Pa	9.64 $\pm$ 0.14	Lab-expert	2008	1	9.38	-2.7
		Mine	2006	113	9.25	-4
			2007	106	9.41	-2.4
			2008	12	9.42	-2.3
		SGS	2004	31	9.31	-3.5

Standard #	Nominal Value $\pm$ 1 Standard Deviation	Laboratory	Year	Number of CRM Assays	Average	Difference (%)
			2005	71	9.45	-2
			2006	44	9.26	-3.9
		Swastika	2006	23	9.46	-16.5
		Techni-Lab	2006	93	9.14	-5.2
62Pb	11.33 $\pm$ 0.17	Mine	2007	10	9.46	-16.5
		SGS	2004	86	10.47	-7.6
62F	9.71 $\pm$ 0.239	Mine	2019	3	9.53	-1.85
			2020	15	9.87	1.65
			2021	32	9.87	1.65
			2022	59	9.55	-1.61
			2023	13	9.73	0.17
		Swastika	2019	302	9.62	-0.93
			2020	144	9.65	-0.62
			2021	56	9.59	-1.24
			2022	132	9.67	-0.40
			2023	15	9.68	-0.27
		MSA Labs	2022	11	9.89	1.81
204	1.043 $\pm$ 0.039	Mine	2013	401	1.05	0.7
			2014	361	1.05	-0.26
			2015	535	1.04	0.54
			2016	482	1.05	-0.19
			2017	85	1.15	-9.09
			2018	129	1.04	0.16
		Swastika	2013	77	1.02	-2.2
			2014	140	1.02	2.1
			2015	270	1.02	2.13
			2016	69	1.03	1.63
			2017	55	1	4.45
			2018	43	1.04	-0.07
			207	3.472 $\pm$ 0.13	Mine	2014
2015	460	3.5				-0.73

Standard #	Nominal Value $\pm$ 1 Standard Deviation	Laboratory	Year	Number of CRM Assays	Average	Difference (%)	
			2017	2	1.6	117	
			2018	1	1.61	116.65	
			2022	1	3.28	-5.53	
		Swastika		2014	48	3.49	-0.63
				2015	266	3.48	-0.13
				2016	65	3.46	0.33
				2017	196	3.43	1.22
				2018	2	3.47	0.06
				2022	3	3.44	-1.02
208	9.248 $\pm$ 0.438	Mine	2016	465	9.4	-1.59	
			2017	282	9.33	-0.84	
			2018	171	9.33	-0.88	
			2019	140	9.4	1.64	
		Swastika	2017	30	8.95	3.28	
			2018	38	9.24	0.04	
			2019	4	9.59	3.7	
209	1.580 $\pm$ 0.044	Mine	2016	14	1.58	-0.05	
			2018	439	1.59	-0.83	
			2019	375	1.57	-0.63	
			2020	116	1.55	-1.9	
			2021	17	1.55	-1.9	
			2022	5	1.57	-0.51	
			2023	4	1.56	-1.42	
		Swastika	2017	185	1.62	-2.49	
			2018	132	1.57	0.37	
			2019	6	1.585	0.31	
			2020	18	1.57	-0.63	
			2021	2	1.545	-2.21	
			2022	11	1.57	-0.46	
214	3.030 $\pm$ 0.082	Mine	2016	67	3.04	-0.43	

Standard #	Nominal Value $\pm$ 1 Standard Deviation	Laboratory	Year	Number of CRM Assays	Average	Difference (%)
			2017	521	3.01	0.53
			2018	537	3.03	0.14
			2019	315	3.03	0.14
			2020	16	2.975	-1.82
		Swastika	2017	168	2.93	3.44
			2018	176	2.99	1.36
			2019	5	2.97	-1.98
215	3.54 $\pm$ 0.097	Mine	2016	414	3.54	0.13
			2017	1	2.95	-20
			2018	4	3.51	1
			2019	2	3.625	2.4
		Swastika	2018	352	3.5	1.11
			2019	271	3.52	-0.56
221	1.06 $\pm$ 0.04	Swastika	2017	152	1.11	-4.81
			2018	356	1.07	-1.25
			2019	327	1.06	-0.19
			2020	135	1.06	-0.19
			2021	59	1.09	2.83
		Mine	2018	1	1.16	-8.62
			2019	1	1.07	0.75
			2020	13	1.07	0.75
221	1.06 $\pm$ 0.04	Mine	2021	26	1.06	-0.19
228	8.73 $\pm$ 0.28	Mine	2017	334	8.89	-1.8
			2018	340	8.81	-0.93
			2019	198	8.78	0.57
			2020	107	8.75	0.23
			2021	31	8.74	0.11
			2022	2	8.85	1.37
		Swastika	2017	157	8.4	3.98
			2018	128	8.69	0.48
			2019	3	8.76	0.34

Standard #	Nominal Value $\pm$ 1 Standard Deviation	Laboratory	Year	Number of CRM Assays	Average	Difference (%)		
233	1.050 $\pm$ 0.03		2020	15	8.75	0.23		
			2021	18	8.85	1.37		
		Mine	2022	71	1.06	0.64		
			2023	31	1.04	-1.23		
		Swastika	2022	75	1.24	17.93		
			2023	27	1.06	1.27		
MSA Labs	2022	13	1.73	64.84				
235	1.59 $\pm$ 0.04	Mine	2021	23	1.55	-2.52		
			2022	71	1.57	-1.02		
			2023	109	1.56	-1.74		
		Swastika	2021	29	1.56	-1.89		
			2022	38	1.56	-2.12		
			2023	70	1.59	-0.25		
		MSA Labs	2022	2	1.59	0.28		
		238	3.03 $\pm$ 0.08	Mine	2019	32	3.03	-0.11
					2020	97	3.02	-0.33
2021	27				2.99	-1.32		
2022	52				2.99	-1.39		
2023	84				3	-0.83		
Swastika	2020			15	2.978	-1.72		
	2021			22	3.08	1.65		
	2022			54	3.02	-0.42		
	2023			66	3.03	-0.15		
MSA Labs	2022			1	3.02	-0.43		
239	3.55 $\pm$ 0.09			Swastika	2019	74	3.54	-0.28
					2020	138	3.55	0.16
		2021	53		3.45	-2.82		
		2022	96		3.50	-1.51		
		2023	75		3.52	-0.78		
		Mine	2020	14	3.49	-1.69		
			2021	28	3.51	-1.13		

Standard #	Nominal Value $\pm$ 1 Standard Deviation	Laboratory	Year	Number of CRM Assays	Average	Difference (%)
242	8.670 $\pm$ 0.22		2022	64	3.54	-0.32
			2023	102	3.47	-2.33
		MSA Labs	2022	13	3.59	1.10
		Mine	2023	15	8.51	-1.71
		Swastika	2022	2	8.65	-0.29
243	12.390 $\pm$ 0.31		2023	4	8.67	0.00
			2023	37	12.35	-0.34
245	25.730 $\pm$ 0.55		2023	7	12.47	0.61
			2023	34	24.27	-5.66
SG99	1.041 $\pm$ 0.02	Mine	2023	4	25.31	-1.65
			2023	4	25.31	-1.65
		Swastika	2020	15	1.03	-0.96
			2021	30	1.03	-1.15
			2020	70	1.05	0.96
SG113	1.024 $\pm$ 0.02	Mine	2021	56	1.07	2.65
			2022	2	1.06	1.83
		Swastika	2022	34	1.03	0.73
			2023	40	1.02	-0.44
		MSA Labs	2022	9	1.09	6.72
SH82	1.33 $\pm$ 0.007	Mine	2022	42	1.04	1.82
			2023	36	1.04	2.02
			2020	36	1.31	-1.5
		Swastika	2021	25	1.43	7.52
			2022	4	1.41	5.40
			2020	8	1.3	-2.25
SK109	4.10 $\pm$ 0.03	Mine	2021	19	1.3	-2.25
			2022	31	1.31	-1.92
		Swastika	2020	15	4	-2.44
			2021	29	3.94	-3.9
			2020	54	3.98	-2.93
			2021	53	4.06	-0.98
			2022	1	3.51	-14.43

Standard #	Nominal Value $\pm$ 1 Standard Deviation	Laboratory	Year	Number of CRM Assays	Average	Difference (%)
SK120	4,075 $\pm$ 0.09	Mine	2022	38	4.08	0.22
			2023	21	3.97	-2.48
		Swastika	2022	65	4.08	0.19
			2023	26	4.09	0.39
		MSA Labs	2022	8	4.18	2.49
SN104	9.182 $\pm$ 0.18	Mine	2022	2	6.34	-31.01
		Swastika	2022	1	8.75	-4.70
SN106	8.46 $\pm$ 0.05	Mine	2020	35	8.54	0.95
			2021	35	8.45	-0.12
			2022	27	8.08	-4.54
			2023	45	8.35	-1.37
		Swastika	2020	9	8.64	2.13
			2021	23	8.7	2.84
			2022	48	8.54	0.88
			2023	20	8.46	-0.07
SN117	8.443 $\pm$ 0.11	Mine	2022	61	8.41	-0.37
			2023	82	8.40	-0.51
		Swastika	2022	25	8.39	-0.93
			2023	54	8.47	0.32
		MSA Labs	2022	4	8.73	3.35

#### 8.4.7 BLANKS

The coarse blank material used for Casa Berardi QA/QC in 2023 was commercially available material obtained from a local home improvement store. Multiple samples were assayed to confirm the viability of the material for use as blanks. Of the 1,439 total coarse blank samples assayed at Labomine and Swastika, 861 returned values below the detection limit and 559 returned detectable values but within acceptable limits. A total of 19 samples (1.32%), shown in Figure 8-7, were above the warning limit of 0.1g/t Au, which is 10-times the detection limit of the labs. Only two of the 19 assays exceeding the warning limit were at or above the potential open-pit cutoff grade of 0.85g/t Au. Both of the highest assays, as well as the majority of the assays exceeding the warning limit, were from Labomine.

Figure 8-7. Mine and Swastika Blanks – 2023

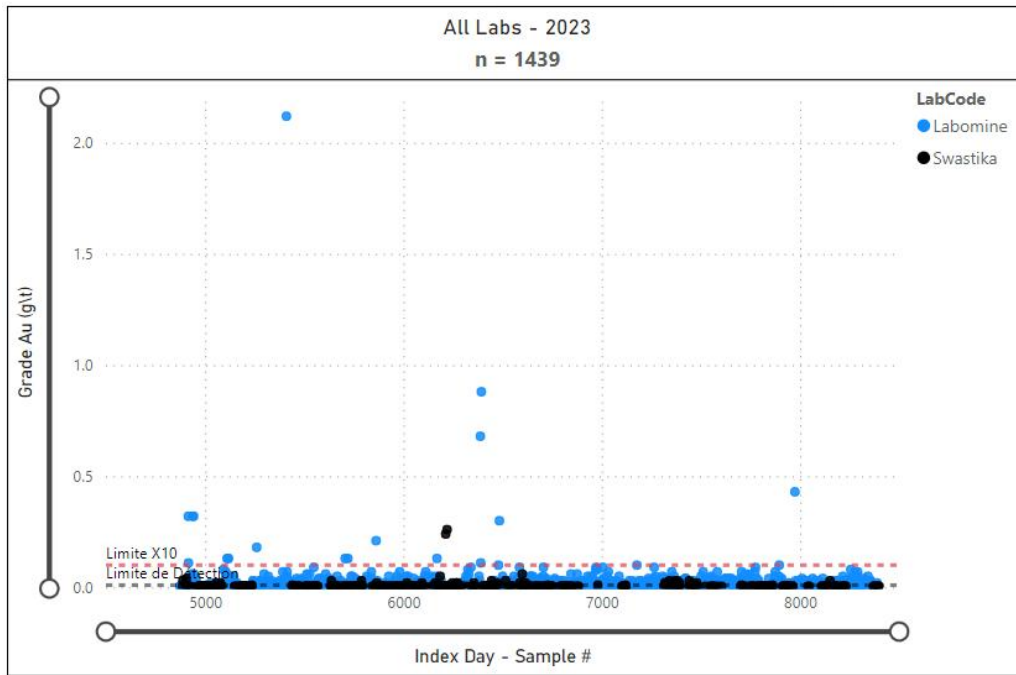

The overall low number of detectable assays above the warning limit, and the very low number at meaningful grades, indicate that there is no systematic contamination during sample preparation. Regardless, Hecla investigates each case where blank assays exceed the warning limit, and re-assays batches if in mineralized intervals. RESPEC has not evaluated any blank assay data generated prior to 2023. The laboratories should be notified immediately of any problematic blank assays that may be due to contamination during sample preparation.

The assay values for the samples preceding the blank sample are not known to RESPEC, but the information could be useful to evaluate the problematic assays. For example, high blank assays following mineralized intervals likely indicate contamination during sample preparation of the blank from the previous sample.

95  
95

## 8.5 MINE LABORATORY INTERNAL QA/QC PROGRAM

Labomine conducts an internal QA/QC program, which includes the analysis of one blank sample, one CRM, and one duplicate for every 24 samples. Results of the Labomine laboratory QA/QC program are provided to the Casa Berardi geology department, which compiles them into graphs and evaluates the results. The mean grades and average percent differences from target values for each CRM assayed in 2023 are given in Table 8-5. The lab used 11 CRMs for the internal QA/QC program. No information regarding results of the CRM analyses by the mine lab was reviewed, although Hecla reports that few failures generally occur.

Table 8-5. Casa Berardi Laboratory Program CRMs

Type	Nominal Value (g/t Au)	Mean Grade (g/t Au)	Difference (%)	Number of Assays
OxE182	0.663	0.663	(0.04)	704
SH82	1.333	1.299	(2.55)	78
SH98	1.400	1.392	(0.57)	480
OxK160	3.674	3.643	(0.84)	154
OxK175	3.843	3.810	(0.85)	375
OxL63	5.867	5.792	(1.28)	263
SL123	5.899	5.825	(1.25)	287
OxN155	7.762	7.712	(0.64)	24
OxK173	7.668	7.639	(0.38)	242
OxN155	7.776	7.659	(1.50)	73
SP73	18.17	17.726	(2.44)	144

## 8.6 REVERSE-CIRCULATION AND SONIC DRILLING SAMPLES

Neither RESPEC nor Hecla have any information regarding the sample preparation, analysis and security of RC drilling, which was primarily performed by Lakeshore outside the mine permit area. RESPEC also does not have any information for sonic drilling performed by Hecla in 2022 and 2023.

## 8.7 CONCLUSIONS AND RECOMMENDATIONS

In RESPEC's opinion, the sample preparation, analyses, QA/QC protocols and results, and security are acceptable, meet generalized industry standard practice, and provide support that the assays produced by Swastika and Labomine are generally sufficient for use in Mineral Resource and Reserve estimation. RESPEC concludes the following:

/ Sample collection and core-handling practices are adequate, such that potential sample losses and sampling biases are limited;

96  
96

- / The Labomine has followed similar sample preparation and analyses procedures since 2006 when operated by Aurizon through acquisition by Hecla in 2013 to the present. Laboratory staff was generally maintained during the 2013 acquisition. Swastika is an independent, accredited lab. Labomine generally follows sample preparation and analytical procedures that are consistent with commercial labs;
- / In recent years, core from surface exploration and infill diamond drilling programs are and have been analyzed by Swastika, which is an independent and accredited laboratory, for gold and silver analyses;
- / Sample analyses for underground production headings, and infill and definition drilling are performed by Labomine. Run-of-mine samples for the open pits have also been sent to Labomine for assay;
- / The available QA/QC program results indicate that the sample preparation and analytical procedures at Labomine and Swastika laboratories are adequate, and that reliable and accurate assays are being generated; and QA/QC results are summarized as follows:
  - » Blank sample results in 2023 imply minimal systematic contamination during sample preparation. The majority of blank assays exceeding the warning limit were associated with the mine lab.
  - » Aurizon and Hecla investigated and re-assayed each batch containing mineralized samples associated with the CRM failures, and took steps accordingly, which reduces the risk to the model and estimate.
  - » For the 2023 CRM data, there was low bias in CRM assays observed on charts for OREAS 285 for the mine lab, but no bias was observed for Swastika. Variability in CRM assays was higher associated with the mine lab.
  - » Regularized pulp rechecks for the primary laboratory’s internal QA/QC programs resulted in a relatively low proportion of duplicate checks for mineralized samples. Check assays sent to ALS targeted mineralized intervals, and a majority of samples sent had gold grades equal to or greater than 0.1g/t Au.
  - » Results of pulp duplicate assays indicate minimal bias between the means of original and means of duplicate sample assays, with the exception of two years. Assay variability, which is a measure of the heterogeneity of gold in the deposit, cannot be determined from the averaged data.
  - » External pulp and reject check assays indicate that the ALS gold assays are biased high relative to the Swastika and the mine laboratories.
- / Sample security is regarded as good. All samples remain within the mine site, which has no road access except through security at the front gate, until they are processed by the mine lab or picked up by the external lab. Samples are always attended or locked in the on-site logging, sampling or storage facilities. Chain of custody procedures consist of sample submittal forms that are sent with sample shipments, which allows for shipment tracking to ensure that all samples are received by the laboratory.

RESPEC makes the following recommendations:

- / Investigate the high bias in ALS pulp duplicate assays relative to the Labomine and Swastika lab original assays;
- / Discontinue external check assays for coarse reject material;
- / Implement procedures that will reduce CRM mislabeling or “swaps”;
- / Evaluate duplicate, CRM, blank and check assays independently for each lab;

97  
97

- / Track CRM assay failures by lab for each standard, and document steps taken to follow up on the failures;
- / Evaluate duplicate data on plots that show individual sample pairs. Averages of data provides an overall measure of assay bias, but does not characterize assay variability, which is usually a function of natural heterogeneity of gold in the deposits. Individual plots also better characterizes bias; and
- / Investigate blank assay values that exceed a 5x detection limit, and particularly those that are at or above potential mining cutoff grades. Evaluate relative to preceding assay values to determine if contamination could be occurring from previously processed mineralized samples. Document follow-up process and results.

# 9.0 DATA VERIFICATION

## 9.1 SITE VISIT

RESPEC visited Casa Berardi on September 18-22, 2023. The initial F160 Pit Phase was nearing completion while RESPEC QPs were at site, and underground mining operations were expected to cease within a year. RESPEC held meetings with site personnel and followed up with a number of teleconference meetings after the site visit.

RESPEC engineering QPs visited the F160, East Mine Crown Pilar (EMCP), western extension (XMCP) Pit, the West Mine underground, tailings storage facilities (TSF), core logging facilities, and surface infrastructure.

The geology of the gold mineralization was observed underground in the Principal and West deposits, in the F160 and EMCP open pits, and in core from various areas by RESPEC's geology QP. An underground diamond drill in the process of drilling core hole CBW-1223 was also visited. Core processing and sample handling procedures were reviewed in the core shack, and Hecla provided a tour of the mine laboratory. Resource modeling and estimation procedures were discussed in detail with Hecla Québec's Principal Geologist, Real Parent.

## 9.2 DRILL-HOLE DATABASE COMPILATION AND VERIFICATION BY HECLA

Geovia Surpac 2023 Refresh 3 (x64) was used to perform Mineral Resources estimations, manage drill-hole data, and generate 3D wireframe models. The drill-hole data is stored in SQL Server, and versions are frequently backed up in a separate MS Access database.

The lithological log data is validated during the process of geologic modeling on section and plan. The logged data are further checked in context with historical drill data and geochemical samples. Similarly, collar and down-hole survey data are checked to ensure that the hole and sample locations are in reasonable context with topography, underground development, and other data. Down-hole surveys are also evaluated for unlikely and radical bends in drill-hole traces.

Prior to importing sample assay results, the Hecla geologists evaluate the QA/QC data for possible blank or CRM failures. All assays within a given part of the sample batches associated with the failures are rerun if the intervals are mineralized, and the re-assays used in the database if warranted. Assay sample results are then imported to the SQL database, and the QA/QC sample failures and the steps taken to remediate the associated assay data are documented. Once imported, Hecla geologists reconcile the assay results with their data entered into Log Chief during logging and adjust if necessary. Assays are also imported to Leapfrog, where logic of assay locations are evaluated relative to geology and surrounding assays, and sample numbers are checked in core photos. Finally, the majority of assays in mineralized zones are compared to original assay certificates. Any issues found in the data during these checks are corrected in the database.

All down-hole deviation measurements obtained using Sprint-IQ, Tn14, or EZTrack instruments are evaluated for radical bends in drill-hole traces and other logic issues by the geologist, modified as needed, and uploaded to the

99  
99

Reflex cloud-based platform (ImdexHub). The data is checked to ensure that the adjustment for magnetic declination of  $-12.5^\circ$  has been applied to all azimuth measurements. A correction of  $+0.41^\circ$  on the azimuth is also applied to account for the local mine grid offset. All accepted data is flagged as validated, and the flagged down-hole surveys are automatically imported into the database. The Hecla geologist then verifies that the down-hole deviation data have been properly imported.

When possible, surface drill-collar locations, as well as azimuth and inclination data, are surveyed. Coordinate data is manually entered and compared with the planned parameters. Surface and underground drill-hole collars are visually reviewed against topography and underground development wireframes, respectively, as well as other drill holes during modeling. For underground drilling the azimuth is measured on the drill rig before the drilling begins.

## 9.3 DRILL-HOLE DATABASE VERIFICATION BY RESPEC

RESPEC verified Hecla's 2021, 2022 and 2023 drill-hole data to confirm that the data have been generated with proper procedures, have been accurately transcribed from the original sources and are suitable to be used. Additional confirmation of the drill data's reliability is based on the evaluations of the Casa Berardi drill project QA/QC procedures and results, as described previously, and in working with the data during the model review process.

Hecla's Casa Berardi full project drill-hole data was provided to RESPEC as a SQL database that contained drill-collar coordinates, down-hole surveys, and assays. In January 2024, RESPEC conducted verification of Hecla's database in two phases: Phase 1 involved running a series of logical tests against the current modeling database to test for data integrity issues, and correction/explanation of and documentation of any issues. For Phase 2, collar coordinates, down-hole surveys and assays were compared to original certificates or proxy data files.

A single digital file for each of the collar coordinate and down-hole survey compilations was received from Hecla. The assay certificate data was downloaded from a Hecla-controlled distribution site. A separate database was compiled from these files in GeoSequel, which was then compared against the Casa Berardi Project SQL database.

### 9.3.1 PHASE 1 – LOGIC TESTS

The initial phase logical tests of the database included a series of queries to validate the modeling database (Hecla's project SQL database). The following validation tests were conducted to identify:

- / Collars: identify collars with missing depths, collars with missing coordinates, switched or duplicated coordinates, drill holes without assay intervals or intervals without assays, drill holes without collar survey information, drill holes without geology, and drill holes with illogical geotechnical information (core holes only);
- / Surveys: identify survey depths greater than total depth, survey points missing azimuth or dip values, surveys with azimuth readings above  $360^\circ$  or below  $0^\circ$ , surveys with positive or flat dip angles ( $< \sim -45^\circ$ ), or outside  $-90^\circ$  to  $+90^\circ$ ; and
- / Assays: identify illogical or incorrect 'from' and 'to' intervals; excessively large or small assay or geologic intervals, assay, geologic or geotechnical intervals that are greater than collar total depth, gaps and overlaps in assay, geologic or geotechnical intervals.

100  
100

Several minor data integrity issues were found, mostly involving sample overlaps and mistyped assay intervals. Hecla personnel were notified of these issues, and they were corrected in Hecla's database.

### 9.3.2 PHASE 2 –ASSAY DATA VERIFICATION

The second phase of the data validation process was the most comprehensive, comparing Hecla's Casa Berardi Project database to the database created from original certificates imported by RESPEC into the GeoSequel system. Hecla provided RESPEC with the Swastika, MSALabs and mine laboratory certificates in .csv and .pdf files, so RESPEC could not verify the sources to be actual downloads from the original laboratory. However, the .pdf certificates from MSALabs and Swastika appeared to be in standard formats from those laboratories. In all, 2,527 certificates with 113,677 individual sample assays were imported. Of the total, 22,997 were Hecla or internal laboratory QA/QC samples, which gives an overall QA/QC rate of 20.23%. A digital audit was performed on 100% of the remaining 85,903 gold assay records. Only 20 gold assays (0.023% error rate) in Hecla's database did not match the certificate assays. Hecla was notified of all significant differences found, which were corrected in Hecla's database.

## 9.4 COMMENTS ON DATA VERIFICATION

Compilation and subsequent verification of the Casa Berardi database has been performed by Hecla personnel since 2014. All data has been compiled by Hecla staff as it is generated and imported into the Gem Logger or Log Chief databases. Once compiled and loaded for modeling, collar coordinate, down-hole survey and geology data are reviewed in context with topography and surrounding data. Assay results are also evaluated relative to geology and surrounding assays, sample numbers are checked in core photos, and mineralized zones are compared to original assay certificates. Any issues found in the data during these checks are corrected in the database.

During the site visit, RESPEC observed the geology of the Casa Berardi deposit and confirmed the presence of alteration and quartz-veining that is conducive to gold mineralization. Mined versus modeled reconciliations, which were generally reasonable, were reviewed. RESPEC reviewed Hecla's process for compiling collar, down-hole survey, and assay drill-hole data, and the verification of that data once it is entered. RESPEC considers that a reasonable level of verification is completed on a regular basis to ensure that all data has been compiled accurately.

External reviews of the database have been undertaken in support of acquisitions, support of feasibility level studies, and in support of Mineral Resource and Mineral Reserve estimates in the past, producing independent assessments of the database quality. However, RESPEC has not reviewed any of these external reviews, and does not rely on their results and conclusions for data verification.

RESPEC conducted an audit to verify all 2021, 2022 and 2023 assay data, and discovered only 20 discrepancies in 85,903 assay records. RESPEC did not review data prior to 2021 for several reasons:

- / The quantity of data audited from 2021, 2022 and 2023 was substantial;
- / 100% of the 2021, 2022 and 2023 data was verified, which yielded an acceptable 0.023% failure rate. Hecla has stated that similar compilation and verification procedures have been implemented prior to 2021, so it is not unreasonable to expect that the database assays compiled prior to 2021 are equally reliable;

101  
101

- / Hecla's productive mining history using models that relied on pre-2021 data compilations and positive mined vs modeled reconciliations provide a level of confidence in past assay databases; and
- / Much of the underground mineralized material drilled prior to 2021, and some of the open pit material, has been mined out.

RESPEC is satisfied that the data compilation and verification programs performed by Hecla on the Casa Berardi project drill-hole data adequately ensures that the data contained in the resulting database is sufficiently accurate. Given Hecla's database validation process, RESPEC's verification of all 2021, 2022 and 2023 assay data, and the fact that Hecla has been modeling and mining at Casa Berardi using data compiled and verified in a similar manner for ten years, the drill-hole database is considered to be sufficient for use in geological and mineral domain modeling, Mineral Resource and Mineral Reserve estimation, and mine planning.

102  
102

RSI-M0206.22001

---

# 10.0 MINERAL PROCESSING AND METALLURGICAL TESTING

This section was contributed by SLR. The SLR QP has reviewed the information disclosed in this section and takes full responsibility for this information.

## 10.1 INTRODUCTION

The Casa Berardi processing plant originally commenced production in September 1988 and production was suspended in September 1997. During this initial production period, the plant processed 3.5 Mt of ore with an average grade of 7.1 g/t Au and average mill gold recovery of 87%. A total of 688,400 oz Au were recovered.

Production restarted in early November 2006, and commercial production was achieved as of May 1, 2007. Since 2006, a total of 16.1 Mt at an average grade of 5.20 g/t Au have been milled at Casa Berardi for a gold output of 2.37 Moz Au as of the effective date of this report.

The mill received ore from the EMCP and XMCP pits from August 2016 and subsequent years. Ongoing processing plant operations demonstrate the levels of gold recovery to be expected from the underground ores. LOM projected mill recoveries range from 81.3% to 91.5% for the underground Mineral Reserves and from 85% to 90.2% for the open pit Mineral Reserves. Milling of ore from the F160 Pit began in Q4 of 2022.

Historical metallurgical test work programs and results were previously reported by Hecla (2019) and SLR (2022). Relatively recent test work programs, both internal and external, have been performed to support current operations and potential improvements, including:

- / Blue Coast Research Ltd. (Blue Coast) (Parksville, B.C.), Project No. PJ5308 (Blue Coast, 2020b) – metallurgical investigations were undertaken on the WMCP material;
- / Blue Coast (Parksville, B.C.), Project No. PJ 5333 (Blue Coast, 2021a) – metallurgical investigations were undertaken on the Principal Pit material;
- / Blue Coast (Parksville, B.C.), Project No. PJ 5339 (Blue Coast, 2021b) – metallurgical investigations on flotation were undertaken on the WMCP material;
- / Blue Coast (Parksville, B.C.), Project No. PJ 5348 (Blue Coast, 2022) – Phase 2 metallurgical investigations were undertaken on the WMCP material; and
- / Blue Coast (Parksville, B.C.), Project No. PJ 5399 (Blue Coast, 2023) – metallurgical investigations were undertaken on the WMCP Extension.

Blue Coast is a commercial metallurgical testing laboratory independent of Hecla.

Since the mine has been operating steadily since 2006, the metallurgical recoveries are based primarily on operating data.

The SLR QP reviewed the following data provided by Casa Berardi:

103  
103

- / Recent metallurgical test work programs;
- / Historical mill production and recovery data; and
- / Production reports.

## 10.2 METALLURGICAL TESTING

The following sections describe the metallurgical testing undertaken during the period of 2020 to 2023 that was not previously reported. Information was largely summarized from the reports prepared by Blue Coast covering the following test programs:

- / 2020 WMCP Test Program (Blue Coast, 2020b);
- / 2021 Principal Pit Test Program (Blue Coast, 2021a);
- / 2021 WMCP Flotation Test Program (Blue Coast, 2021b);
- / 2022 WMCP Phase 2 Test Program ((Blue Coast, 2022); and
- / 2023 WMCP Extension Program ((Blue Coast, 2023).

### 10.2.1 2020 WMCP TEST PROGRAM

In 2020, a test work program was completed by Blue Coast on mineralized material from the WMCP Pit. The objective of this test program was to evaluate the potential for WMCP Pit material to become a valuable ore source for mining in the near future. For this assessment, chemical and mineralogical characterization, comminution, and cyanidation tests were completed on 17 different composite samples and blends.

#### 10.2.1.1 SAMPLE PREPARATION AND ANALYSES

Hecla selected drill core intervals from the WMCP area and submitted the material for composite preparation and metallurgical testing to Blue Coast. A total of 640kg of material contained in five barrels was received at Blue Coast's facilities in Parksville, B.C., Canada in July 2020. Hecla created 17 composites from the drill core totaling approximately 396 kg. Table 10-1 shows the weights and chemical assays of the 17 WMCP composite samples.

Table 10-2. Chemical Assays of Composite Samples

Composite	Weight (kg)	Au (g/t)	S <sub>tot</sub> (%)	S <sup>2-</sup> (%)	C <sub>tot</sub> (%)	C <sub>org</sub> (%)
105-001LG	61.4	0.74	2.21	1.99	3.81	0.37
105-032LG	65.5	1.11	1.23	1.16	2.44	0.10
105-039LG	51.6	0.86	2.53	2.38	3.19	0.53
105-007LG	54.7	0.95	2.77	2.69	2.96	0.40
105-020LG	53.0	0.77	2.48	2.42	2.22	0.16
105-032MG	2.37	7.57	5.06	4.85	2.86	0.95
105-039MG	19.2	1.66	2.06	1.98	2.96	0.50
105-007MG	10.4	1.75	1.84	1.79	2.78	0.22
105-001MG	8.31	2.71	2.36	2.35	2.69	0.18
105-002MG	8.21	3.99	1.50	1.42	0.82	0.40
105-020MG	32.2	1.89	1.64	1.48	2.02	0.10
105-032HG	6.15	3.69	2.91	2.77	1.78	0.19
105-039HG	9.03	5.46	3.04	2.87	1.94	0.97
105-007HG	9.67	14.21	2.37	2.13	1.77	0.54
105-020HG	5.25	4.61	3.44	3.39	3.39	0.38
Low Grade MC	236.2	0.79	2.28	2.22	2.91	0.32
Mid Grade MC	53.3	1.84	1.76	1.69	2.31	0.21

A mineralogical assessment was conducted on a 50:50 weight percent blend of mid-grade composites 105-020MG and 105-039MG. The sample was dominated by quartz, micas, and feldspars (73% combined) and appreciable calcite was present (11%). Pyrite (3.76%) was the dominant sulfide followed by arsenopyrite (1.19%). The modal mineralogy is shown in Table 10-2.

105  
105

**Figure STYLEREF 1 \s 10-. Mineralogical Analyses on Composites**

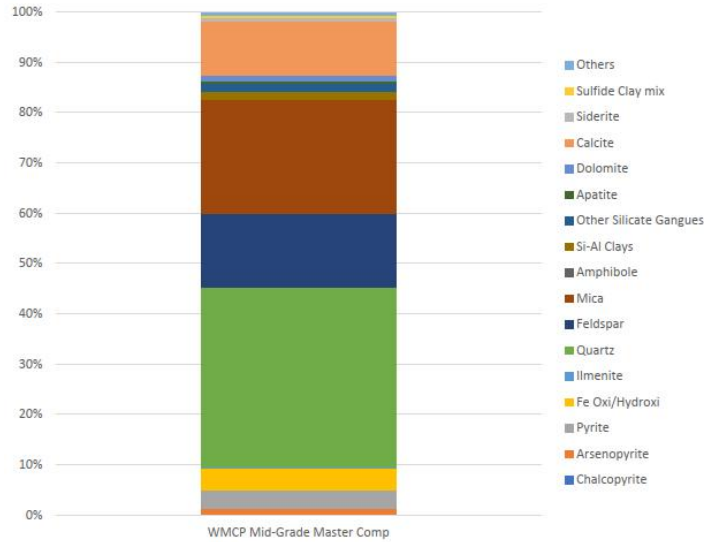

A trace mineral search was conducted on the mineralogy composite polished sections. A total of nine grains were found, all identified as electrum. The electrum grains ranged in size from one micron to 13 µm and the vast majority of the grains were associated with sulfides (pyrite followed by arsenopyrite). The close association of gold with the sulfides could make this material a candidate for flotation ahead of cyanidation.

### 10.2.1.2 COMMINUTION TESTING BY SGS

Three comminution composite samples were submitted to SGS Mineral Services in Burnaby, B.C., Canada for Semi-Autogenous Grinding (SAG) Mill Comminution (SMC) testing and Bond Abrasion Index (Ai) testing. Bond Ball Mill Work Index (BWI) testing was performed at Blue Coast. SGS is independent of Hecla.

Results from the SMC tests showed that the three samples had Axb values ranging from 67.3 to 78.1, which indicates that the material is moderately soft. Ai test results ranged from 0.196 to 0.303, indicating that the material is moderately abrasive. BWI test results were consistent between each composite sample and ranged from 13.6kWh/t to 13.8kWh/t, which suggested the material was of medium hardness. Table 10-2 summarizes the results of the comminution test work.

**Table STYLEREF 1 \s 10-. Comminution Test Results on Composites**

Composite	SMC Test					BWI	Bond Abrasion Index	
	A	b	Axb	ta	DWI	(kWh/t)	Ai	POA *
LG 1-2	78.1	0.54	42.2	0.39	6.55	13.6	0.303	60
LG 3-5	67.3	0.74	49.8	0.46	5.64	13.6	0.196	40
MG	68.0	0.77	52.4	0.47	5.48	13.8	0.284	57
Average	71.1	0.68	48.1	0.44	5.89	13.7	0.300	52

Notes: \* Percentile of abrasivity

### 10.2.1.3 GRAVITY TESTING BY SGS

Gravity Recoverable Gold (GRG) test work is typically performed using a laboratory scale centrifugal gravity concentrator and a Knelson MD-3 unit was employed for this study. A single Extended Gravity Recoverable Gold (E-GRG) test was conducted on the Mid-Grade Master Composite. During an E-GRG test a 20-kg sample was passed through the Knelson MD-3, with the tails of each subsequent gravity pass being ground successively finer. Target grind sizes for each pass were 80% passing (K80) 850µm, 250µm and 75µm. Grind calibrations were performed using a 10-kg sample of the material to determine approximate grind times required to achieve the target particle size for each stage of gravity recovery.

Results from the E-GRG test indicated that the Gravity Recoverable Gold (GRG) content of the sample was 42.6%. However, the majority of the GRG was noted as being fine and harder to liberate. This agrees with the general observations from the gold mineralogy study, which noted that electrum grains ranged between one micron to 13µm.

### 10.2.1.4 CYANIDATION TESTING BY SGS

A total of 48 benchtop cyanidation tests were completed during this test program.

Bottle Roll Leach Tests.

Tests CN-1 through CN-4 were conducted as 4.4lb (2.0kg) coarse bottle roll leach tests to examine the response of the Low-Grade Master Composite across a series of crush sizes (100% passing 1.5in., 0.75in., 0.5in., and 10mesh (1.7mm)). Four coarse bottle roll leach tests were conducted at 40.0% solids with a sodium cyanide concentration of 1.0 g/L of solution, leached for a total of 96 hours, and sampled at two, six, 24, 72, and 96 hour intervals. Residues from each test were sized and size by size assays were conducted.

The 10 mesh sample had the highest gold recovery at 16.9%. Recovery was low in tests with coarser crush sizes. Overall recovery was poor across each leach test and therefore, no column leach test work was undertaken.

Stirred Leach Tests

Prior to leach test work, two-point grind calibration tests were performed on each composite to determine appropriate grind times. Tests CN-4 through CN-48 were conducted as 1.0kg stirred leaches with carbon to test the response of the 15 variability composites across three target primary grind sizes (106µm, 75µm, and 53 µm) at 50% solids. Due to the limited mass for sample 105-032MG, only two grind sensitivity tests were performed. All stirred leaches were conducted as carbon-in-leach (CIL) tests at an addition rate of 15.0g/L pulp with a 24-hour retention

107  
107

time. Sodium cyanide concentration was maintained at 1.0g/L. Kinetic sub-sampling of both liquor and solids was performed at two, six, 10, 20, and 24 hour intervals.

Cyanidation test work on the WMCP material showed that:

- / Coarse bottle roll tests resulted in low gold recovery ranging between 7% to 17%, suggesting this material would not be amenable to heap leaching;
- / Gold recovery from CIL tests ranged from 51.2% to 93.0%. The variability in recovery between samples was much higher than that observed in earlier phases of work on samples from the F160 Pit;
- / A composite sample with higher head grades had higher overall recovery, however, significant variability was noted and the correlation was weak; and
- / Finer primary grinds returned slightly higher overall gold recoveries. Grind sizes that were evaluated ranged from 80% passing 106µm to 80% passing 53µm.

During discussions between Blue Coast and Casa Berardi, it was noted that some of these composites were taken from the edge of the mineralized zone, which may have explained some of the variability in recovery. Therefore, additional test work was recommended using samples collected from within the main mineralized envelope.

The following recommendations were made for future test work:

- / Conduct follow-up test work on new samples collected from within the main mineralized envelope of the WMCP area;
- / Evaluate the potential for flotation to recover gold;
- / Conduct cyanidation test work on flotation concentrates, both with and without regrinding; and
- / Evaluate the benefits of lead nitrate addition and higher cyanide concentrations to improve gold extraction.

## 10.2.2 2021 PRINCIPAL PIT TEST PROGRAM BY BLUE COAST

Blue Coast was contracted by Hecla to execute a metallurgical test work program on material from the Principal Pit area of the Casa Berardi Mine. The purpose of the test work program was to evaluate the potential of the Principal Pit material to become a valuable ore source for mining in the near future. Test work included chemical characterization and cyanidation. A total of nine composites were evaluated during this test work program.

### 10.2.2.1 SAMPLE PREPARATION AND ANALYSES

Hecla selected drill core intervals from the Principal Pit area and submitted the material for composite preparation and metallurgical testing to Blue Coast. Approximately 380kg of material contained in three barrels was received at Blue Coast's test facility in Parksville, B.C., Canada in November 2020. Hecla created nine composites from the drill core material totaling approximately 82kg.

Weights and head grades of the nine composites are summarized in Table 10-3.

**Table 10-3. Head Grade Summary**

Composite	Weight (kg)	Au (g/t)	S <sub>tot</sub> (%)	S <sup>2</sup> (%)	C <sub>tot</sub> (%)	C <sub>org</sub> (%)
CBS-09-302	9.440	0.66	0.57	0.54	2.50	0.03

108  
108

Composite	Weight (kg)	Au (g/t)	S <sub>tot</sub> (%)	S <sup>2</sup> (%)	C <sub>tot</sub> (%)	C <sub>org</sub> (%)
CBS-09-303	6.953	2.11	0.77	0.76	2.54	0.04
CBS-09-311	7.323	2.07	0.54	0.53	2.85	0.03
CBS-09-314	6.998	4.72	1.80	1.77	1.87	0.06
CBS-09-320	9.716	1.78	1.73	1.69	3.21	0.07
CBS-09-337	11.001	7.13	3.13	3.18	2.17	0.06
CBS-10-333	9.342	5.51	2.50	2.47	2.14	0.14
CBS-10-360	9.881	1.55	0.82	0.67	1.17	0.03
CBS-17-758	11.020	7.57	2.30	2.08	2.61	0.02

### 10.2.2.2 CYANIDATION TESTING BY BLUE COAST

A total of 27 benchtop cyanidation tests were completed. All 27 tests were conducted as 1.0kg stirred leaches with carbon, testing the metallurgical response of the nine variability composites across three target primary grind sizes.

#### Stirred Leach Tests

Prior to leach test work, two-point grind calibration tests were performed on each composite to determine appropriate grind times. A total of 27 1.0-kg stirred leaches were done on nine composites. Each composite was subjected to three grind sensitivity tests. The primary grind size targets used for the test work were 80% passing 106µm, 75µm, and 53µm, at a solids content of 50%. All stirred leaches were conducted as CIL tests at an addition rate of 15.0g/L pulp with a 24 hour retention time. Sodium cyanide was maintained throughout the stirred leaches at a concentration of 1.0g/L of solution. Each stirred leach included kinetic sub-sampling of both liquor and solids at two, six, 10, 20, and 24 hours.

Cyanidation test work on the Principal Pit material showed that:

- / Gold recovery from CIL tests ranged from 81.6% to 94.8%;
- / No significant relationship between head grade and recovery was observed; and
- / Finer primary grinds returned slightly higher overall gold recoveries. Grind sizes that were evaluated ranged from 80% passing 106 µm to 80% passing 53µm.

The following recommendations were made on future test work:

1. Evaluate the potential for flotation to recover gold;
2. Conduct cyanidation test work on flotation concentrates, both with and without regrinding;
3. Evaluate the benefits of lead nitrate addition, and higher cyanide concentrations to improve gold extraction; and
4. Conduct grindability studies on Principal Pit material.

The grindability studies should include:

- / SMC test work
- / BWI tests
- / Ai Tests

109  
109

It was also recommended to:

- / complete a mineralogy study on Principal Pit material including modal mineralogy and gold associations; and
- / Extend the use of spatial analysis and metallurgical dashboard development to other deposits associated with the Casa Berardi Operation, specifically the WMCP area. This will enable a more detailed analysis of relationships between metallurgical performance, geography, and mineralogy.

### 10.2.3 2021 WMCP FLOTATION TEST PROGRAM

Blue Coast was contracted by Hecla to execute a metallurgical test work program on material from the WMCP area of the Casa Berardi mine. The purpose of the test work program was to evaluate the potential of gold recovery by flotation on the WMCP material. Test work included chemical characterization, flotation, and cyanidation. Two composites were evaluated during this test work program.

#### 10.2.3.1 2021 SAMPLE PREPARATION AND ANALYSES BY BLUE COAST

A previously prepared Low Grade Master Composite (LG MC) was used in testing and a new High Grade Master Composite (HG MC) was also prepared. Sample weights and head grades of the two composites are summarized in Table 10-4.

110  
110

**Table STYLEREF 1 \s 10-. Head Grade Summary, 2021 Blue Coast Work**

Composite	Sample	Weight (%)	Au (g/t)	S <sub>tot</sub> (%)	S <sup>2-</sup> (%)	C <sub>tot</sub> (%)	C <sub>org</sub> (%)
	105-001 LG	22					
	105-007 LG	19					
	105-020LG	18					
	105-032LG	23					
	105-039LG	18					
Low Grade Master Composite	Total	100	0.79	2.3	2.2	2.9	0.3
	105-007HG	41					
	105-039HG	35					
	105-020HG	8					
	105-032HG	16					
High Grade Master Composite	Total	100	9.01	2.7	2.6	1.9	0.7

### 10.2.3.2 2021 FLOTATION TESTING BY BLUE COAST

A total of three rougher flotation tests were conducted on the LG MC sample and two rougher flotation tests were conducted on the HG MC sample. These tests were conducted as kinetic bulk sulfide flotation tests; the baseline reagent scheme was as follows:

- / Potassium Amyl Xanthate (PAX) - a strong xanthate collector used for gold and sulfide mineral flotation.
- / F-140 - medium-weak mixed-alcohol based frother.
- / The conditions tested were primary grind size, copper sulfate dosage, and PAX dosage.

Table 10-5 summarizes the flotation test conditions.

**Table STYLEREF 1 \s 10-. 2021 WMCP Flotation Test Conditions**

Test ID	Feed	Primary Grind, p80 (µm)	PAX Dosage (g/t)	Copper Sulfate Dosage (g/t)
F-1	LG MC	100	75	--
F-2	LG MC	100	75	50
F-3	LG MC	75	75	--
F-4	LG MC	100	75	150
F-5	LG MC	100	125	150
F-6	HG MC	100	125	300

III  
III

Test ID	Feed	Primary Grind, p80 (µm)	PAX Dosage (g/t)	Copper Sulfate Dosage (g/t)
F-7	HG MC	100	125	300

The initial three tests (F-1 to F-3) on the LG MC explored the effect of grind size and the effect of copper sulfate dosage.

Flotation test work on the WMCP material showed that:

- / No benefit was observed from using a finer primary grind size (75µm vs. 100µm);
- / The addition of copper sulfate resulted in an increase in flotation kinetics and in arsenic recovery;
- / Increased PAX dosages did not result in an increase in recovery;
- / The maximum gold recovery achieved on the Low Grade Master Composite was 88.8%, at a combined rougher concentrate grade of 4g/t Au.
- / The High Grade Master Composite flotation test resulted in a gold recovery of 92.9%, at a combined rougher concentrate grade of 37.6g/t Au.

### 10.2.3.3 2021 CYANIDATION TESTING BY BLUE COAST

#### Stirred Leach Tests

A total of two 1.0kg stirred leaches were done on flotation tails (CN-1 and CN-2). Four 0.66 lb (300 g) stirred leaches were conducted on flotation concentrates. The flotation tails were transferred to cyanidation without further grinding. The concentrates were reground to approximately 20 µm in a ceramic jar mill before cyanidation. All leaches were conducted as CIL tests at an addition rate of 15.0 g/L pulp and at a solids content of 50%. Each stirred tails leach included kinetic sub-sampling of both liquor and solids at two, six, 10, 20, and 24 hours. No kinetic sub-samples were collected from the flotation concentrate leaches, except for a single 24 hour residue sub-sample from CN-5. Table 10-6 summarizes the test conditions.

**Table STYLEREF 1 \s 10-. 2021 WMCP Flotation Product CIL Stirred Leach Conditions**

Test ID	Feed	Retention Time (h)	Sodium Cyanide Concentration (g/L)	Additional Conditions
CN-1	F-4 Rougher Tail	24	1	
CN-2	F-6 Rougher Tail	24	1	
CN-3	F-4 Ro Con 1-3	24	2.5	
CN-4	F-6 Ro Con 1-3	24	2.5	
CN-5	F-7 Ro Con 1-3	48	2.5	200 g/t Lead Nitrate
CN-6	F-7 Ro Con 1-3	24	4	

Table STYLEREF 1 \s 10-. Summary of 2021 WMCP Flotation Product CIL Stirred Leach Results

Test ID	Feed	Primary Grind, p80 (µm)		24 hour Au Recovery (%)	Residue Grade Au (g/t)	Reagent Consumption	
		Target	Actual			NaCN (kg/t)	CaO (kg/t)
CN-1	F-4 Rougher Tail	100	99	81.5	0.02	1.25	0.58
CN-2	F-6 Rougher Tail	100	101	72.6	0.22	1.28	0.43
CN-3	F-4 Ro Con 1-3	20	16	70.6	1.31	2.93	0.60
CN-4	F-6 Ro Con 1-3	20	20	91.3	3.06	3.98	0.86
CN-5	F-7 Ro Con 1-3	20	19	91.2*	3.95	7.94	1.03
CN-6	F-7 Ro Con 1-3	20	21	90.4	4.13	6.5	0.83

Note: \* 48 hour Au recovery for CN-5

Cyanidation test work on the WMCP flotation products showed that:

- / Gold recovery from the LG MC concentrate and tails were 70.6% and 81.5%, respectively;
- / Combined flotation and cyanidation recoveries resulted in an overall LG MC gold recovery of 71.8%;
- / Gold recovery from the HG MC concentrate and tails were 91.3% and 72.6%, respectively;
- / Combined flotation and cyanidation recoveries resulted in an overall HG MC gold recovery of 90.0%; and
- / Additional retention time, lead nitrate addition, and increased cyanide concentration did not improve gold recovery.

The following recommendations were made for future test work:

- / Conduct an expanded flotation and cyanidation test work program on material from the WMCP area to further explore the potential recovery benefits of combined flotation and cyanidation; and
- / Conduct further whole ore cyanidation test work on new samples collected from within the main mineralized envelope of the WMCP area.

#### 10.2.4 2022 WMCP PHASE 2 TEST PROGRAM

Blue Coast was contracted by Hecla to execute a Phase 2 metallurgical test work program on material from the WMCP area of the Casa Berardi mine. The purpose of the test work program was to characterize the spatial variability in the WMCP samples and to evaluate the amenability of the WMCP master composites to gold recovery by gravity, flotation, and cyanidation. A total of 39 spatial variability composites and three master composites were evaluated in a two part test work program summarized in this section:

- / Part 1 – Variability Test Work
- / Part 2 – Master Composite Test Work

#### 10.2.4.1 PART 1 – VARIABILITY TEST WORK 2022

##### Sample Preparation and Analyses

Hecla selected drill core intervals and associated coarse rejects from the WMCP area and submitted the material for composite preparation and metallurgical testing to Blue Coast. Approximately 1,200kg of material was received at Blue Coast's test facility in Parksville, B.C., Canada in April 2021.

The coarse reject portions were grouped into 39 spatially discrete variability composites (grouped by drill hole depth data) and the proposed composites were presented to Hecla for approval. Each variability composite was stage crushed to 100% -10 mesh, homogenized, and split into replicate 1.0kg test work charges and head assay sub-samples.

##### Cyanidation Testing

##### Variability Stirred Leach Tests

A 1.0 kg stirred leach was conducted on each of the 39 variability composites. The primary grind size target used for the test work was 80% passing 75 µm at a solids content of 50%. All stirred leaches were conducted as CIL tests at an addition rate of 15.0 g/L pulp with a 24 hour retention time. Sodium cyanide was maintained throughout the stirred leaches at a concentration of 1.0 g/L of solution. Each stirred leach included kinetic sub-sampling of both liquor and solids at two, six, 10, 20, and 24 hour intervals. Table 10-8 summarizes the results from the variability stirred leach tests.

114  
114

Table STYLEREF 1 vs 10-. 2022 WMCP Variability Cyanidation Results

Test ID	Feed	Primary Grind, p80 (µm)	Head Au (g/t)	24 hour Au Recovery (%)	Residue Grade Au (g/t)	Reagent Consumption	
						NaCN (kg/t)	CaO (kg/t)
CN-1	CBF-105-045 A	68	0.45	76.1	0.13	1.10	0.53
CN-2	CBF-105-045 B	68	1.30	61.4	0.51	0.96	0.40
CN-3R	CBF-105-045 C	66	1.58	83.9	0.23	1.42	0.53
CN-4R	CBF-105-045 D	72	0.50	11.2	0.41	1.25	0.55
CN-5	CBF-105-043 A	77	1.01	10.8	0.95	1.11	0.43
CN-6	CBF-105-043 B	78	0.99	28.8	0.77	1.04	0.48
CN-7	CBF-105-043 C	86	0.87	61.4	0.39	1.30	0.42
CN-8	CBF-105-043 D	74	1.35	93.1	0.10	1.26	0.37
CN-9	CBF-105-043 E	67	1.34	90.8	0.10	1.23	0.49
CN-10	CBF-105-048 A	72	1.41	83.8	0.25	1.31	0.55
CN-11	CBF-105-048 B	73	0.84	3.8	0.85	1.64	0.84
CN-12	CBF-105-028 A	69	0.79	54.9	0.36	1.12	0.42
CN-13	CBF-105-036 A	73	0.40	67.8	0.14	0.98	0.56
CN-14	CBF-105-036 B	71	4.90	79.8	1.05	1.10	0.29
CN-15	CBF-105-057 A	76	1.16	91.6	0.11	1.23	0.65
CN-16	CBF-105-057 B	69	0.94	80.2	0.18	1.02	0.60
CN-17	CBF-105-057 C	82	0.60	29.3	0.43	1.55	0.73
CN-18	CBF-105-057 D	85	4.96	84.0	0.72	1.02	0.50
CN-19	CBF-105-057 E	72	1.07	68.5	0.34	0.96	0.49

115  
115

Test ID	Feed	Primary Grind, p80 (µm)	Head Au (g/t)	24 hour Au Recovery (%)	Residue Grade Au (g/t)	Reagent Consumption	
						NaCN (kg/t)	CaO (kg/t)
CN-20R	CBF-105-059 A	75	1.08	70.7	0.34	1.68	0.40
CN-21	CBF-105-050 A	74	0.46	85.6	0.07	1.10	0.51
CN-22	CBF-105-050 B	68	0.50	16.0	0.40	1.47	0.71
CN-23	CBF-105-049 A	79	1.89	83.1	0.32	1.15	0.55
CN-24	CBF-105-049 B	73	2.08	89.2	0.18	1.12	0.52
CN-25	CBF-105-049 C	75	1.00	91.4	0.12	1.05	0.45
CN-26	CBF-105-049 D	62	0.91	20.8	0.83	1.63	0.61
CN-27	CBF-105-049 E	74	0.79	57.5	0.36	1.28	0.57
CN-28	CBF-105-055 A	81	0.32	49.2	0.19	1.26	0.61
CN-29	CBF-105-055 B	80	2.64	72.2	0.77	1.05	0.43
CN-30R	CBF-105-055 C	61	0.54	69.0	0.18	1.59	0.65
CN-31	CBF-105-055 D	82	1.17	53.8	0.54	1.20	0.44
CN-32	CBF-105-058 A	71	0.74	76.3	0.17	1.55	0.60
CN-33	CBF-105-058 B	73	1.94	44.2	1.08	1.42	0.52
CN-34	CBF-105-058 C	73	2.49	68.5	0.84	1.19	0.53
CN-35	CBF-105-060 A	75	0.89	89.1	0.10	1.32	0.46
CN-36	CBF-105-061 A	77	2.55	63.1	0.88	1.53	0.59
CN-37	CBF-105-061 B	75	0.85	49.0	0.43	1.28	0.66
CN-38	CBF-105-067 A	73	2.59	59.8	1.09	1.27	0.32

116  
116

Test ID	Feed	Primary Grind, p80 (µm)	Head Au (g/t)	24 hour Au Recovery (%)	Residue Grade Au (g/t)	Reagent Consumption	
						NaCN (kg/t)	CaO (kg/t)
CN-39	CBF-105-067 B	70	1.67	71.9	0.56	1.35	0.34

These 2022 WMCP variability composites showed significantly more variability in gold recovery than the past WMCP test work programs. Gold recoveries ranged from 3.8% to 93%. On average, composites with higher head grades had higher gold recovery. Additionally, the organic carbon head grade and arsenic head grade were both negatively associated with gold recovery. A multivariate regression analysis was conducted on these results using JMP statistical analysis software. The composite head assays (including Au,  $S_{total}/S^{2-}$ ,  $C_{total}/C_{organic}$  and ICP multi-element scans) and cyanidation data were imported and the JMP software was used to conduct a statistical analysis to determine the factors which have the strongest correlations to gold recovery. This analysis found that gold head grade, sulfur, organic carbon, copper, and arsenic head grade were good predictors of gold recovery.

Further data analyses performed by Blue Coast resulted in:

- / Generation of scatter plots for S vs.  $C_{tot}$  head grade
- / Generation of scatter plots for gold leach recovery vs. NaCN consumption
- / Design and grouping of the composites into three Master Composites as follows:
  - » MC-1 – high gold recovery, low  $S^{2-}$  and low  $C_{org}$
  - » MC-2 – low gold recovery, high cyanide consumption
  - » MC-3 – low gold recovery, low cyanide consumption.

#### 10.2.4.2 PART 2 –2022 MASTER COMPOSITE TEST WORK BY BLUE COAST

##### Sample Preparation and Analyses

Following the Part 1 – Variability Test Work program, three groupings of the variability composites were proposed to Hecla for approval to form the master composites. The drill core intervals associated with each variability composite was grouped into the destination master composite, comminution sub-samples were collected, and the remaining material was stage crushed to 100% -1.5 in., 0.75 in., 0.5 in. and -10 mesh, and test work charges were produced from each size fraction. Head grades of the three master composites are summarized in Table 25.

117  
117

**Table . 2022 Casa Berardi WMCP Master Composite Head Assays**

Composite	Au (g/t)				S <sub>tot</sub> (%)	S <sup>2-</sup> (%)	C <sub>tot</sub> (%)	C <sub>org</sub> (%)	
	Rep.	Average	Cut 1	Cut 2	Cut 3	Cut 1	Cut 1	Cut 1	
MC-1		1.84	1.7	1.77	2.05	1.15	1.13	2.35	0.12
MC-2		1.23	1.2	1.29	1.22	3.48	3.6	2.62	1.06
MC-3		1.18	1.2	1.14	1.19	2.84	2.94	2.82	1.03

Blue Coast submitted sized samples of the three master composites to Activation Laboratories Ltd. (Actlabs) in Ancaster, Ontario, Canada for modal mineralogy and liberation analysis. Actlabs is a commercial laboratory independent of Hecla. All samples were ground to a primary grind size of 80% passing 100µm and analyzed using Quantitative Evaluation of Materials by Scanning Electron Microscopy (QEMSCAN).

Mineralogical analysis showed that:

- / Primary sulfide minerals in the master composite samples were pyrite and arsenopyrite, both of which were well liberated; and
- / The primary non-sulfide minerals were quartz, muscovite, chlorite, calcite, and feldspar.

#### Comminution Testing

One SMC test, one BWI test, and one Ai was conducted on each master composite. The SMC test results indicated that the WMCP material was moderately hard. The BWI was conducted with a closing size of 150µm, and the ball charge was checked prior to the test to ensure that standard BWI test parameters were adhered to. The BWI results indicated the WMCP material would be considered moderately hard. The Ai test was subcontracted to SGS Vancouver in Vancouver, B.C., Canada to perform and the results indicated the WMCP material was moderately abrasive.

#### Gravity Testing

A single E-GRG test was conducted on an equally weighted blend of samples MC-1, MC-2 and MC-3. During the E-GRG test, a 20kg sample was passed through a laboratory Knelson MD-3 unit, with the tails of each subsequent gravity pass being ground successively finer. Target grind sizes for each pass were p80 of 850µm, 250µm, and 75µm. Grind calibrations were performed using a 10kg sample of the material to determine approximate grind times required to achieve the target particle size for each stage of gravity recovery.

Gravity test work on the WMCP samples showed moderate gravity recovery, with 41% GRG content. The gold was relatively fine grained, with only 9.5% of the gold existing in particles greater than 106µm in size.

#### Flotation Testing

A total of 19 flotation tests were conducted throughout the test program. These tests were conducted as bulk sulfide flotation tests; the baseline reagent scheme was as follows:

- / Copper Sulfate – an activator for sulfide minerals;
- / PAX (as described previously in Section 10.2.3.2).
- / Methyl Isobutyl Carbinol (MIBC) – low persistence, alcohol-based frother; and

118  
118

/ The initial conditions selected were based on the previous program flotation work (Blue Coast, 2021b); the conditions tested were primary grind size, solids density, cleaner circuit, carbon pre-flotation, and a selective arsenopyrite/pyrite flowsheet. Two tests were conducted on Knelson/Super-Panner tails, and both the concentrate and tails were transferred to cyanidation.

The 2022 WMCP flotation test conditions are summarized in Table 10-10.

**Table 10-10. 2022 Flotation Conditions**

Test ID	Feed	Primary Grind, p80 (µm)	Solids Density (%)	CuSO <sub>4</sub> (g/L)	PAX (Ro/Cln, g/t)	Notes
F-1	MC-1	100	35	150	50/-	Baseline Rougher (Ro)
F-2	MC-2	100	35	150	100/-	Baseline Rougher
F-3	MC-3	100	35	150	85/-	Baseline Rougher
F-4	MC-1	125	35	150	50/-	Effect of Grind Size Rougher
F-5	MC-2	125	35	150	100/-	Effect of Grind Size Rougher
F-6	MC-3	125	35	150	85/-	Effect of Grind Size Rougher
F-7	MC-1	100	20	150	50/-	Effect of Pulp Density Rougher
F-8	MC-2	100	20	150	100/-	Effect of Pulp Density Rougher
F-9	MC-3	100	20	150	85/-	Effect of Pulp Density Rougher
F-10	MC-1	100	20	150	50/20	Cleaner (Cln)Test
F-11	MC-2	100	20	150	100/25	Cleaner Test
F-12	MC-3	100	20	150	85/25	Cleaner Test
F-13	MC-2	100	20	150	50/-	Carbon Pre-Flotation
F-14	MC-3	100	20	150	85/-	Carbon Pre-Flotation
F-15	MC-1	100	20	150	50/20	Cleaner Test
F-16	MC-1	100	20	150	50/20	Full Circuit Test (Gravity Tails)
F-17	MC-2/3	100	20	150	85/-	Arsenopyrite/Pyrite Selective Flotation
F-18	MC-2/3	100	20	150	85/25	Full Circuit Test (Gravity Tails)
F-19	MC-1/2/3 Blend	100	20	150	50/20	Cleaner Test

Flotation test work on the 2022 WMCP samples showed:

- / Good gold recovery and upgrading was achievable on the MC-1 composite (79% recovery at 63 g/t Au to cleaner 1 concentrate); and
- / MC-2 and MC-3 both showed moderate recovery; however, a high-grade concentrate was not produced (70% recovery at 14g/t to 15g/t Au to cleaner 2 concentrate).

#### Cyanidation Testing

##### Master Composite Bottle Roll Leach Tests

A series of coarse bottle roll leach tests were conducted to determine gold extraction rates at various crush sizes, and to assess potential for column leaching. Samples MC-1, MC-2, and MC-3 were all tested at the following crush sizes: 100% -1.5 in., -0.75 in., and -0.5 in. The coarse bottle roll leach tests were conducted at 40% solids, sodium cyanide concentration was maintained at 1.0g/L, and samples were leached for 96 hours, and kinetic solution checks were conducted at two-, six-, 24-, 48-, 72- and 96-hour intervals. Residues for each test were sized and assayed.

Recovery from MC-1 was moderate, with a maximum gold recovery of 33% at the crush size of 100% -0.75". The gold recovery on MC-2 and MC-3 was very poor at all sizes, with an average recovery of 1.1%. Both MC-2 and MC-3 contained a large quantity of preg-robbing organic carbon, and the recovery potential without CIL was severely limited. Due to the poor gold recovery from MC-2 and MC-3, column leach test work was not undertaken.

##### Master Composite Stirred Leach Tests

Two 1.0-kg whole ore stirred leaches were conducted on each master composite. Two primary grind size targets were used: 80% passing 106µm and 75µm, at a solids content of 50%. All stirred leaches were conducted as CIL tests at an addition rate of 15.0g/L pulp with a 24-hour retention time. Sodium cyanide was maintained throughout the stirred leaches at a concentration of 1.0 g/L of solution. Each stirred leach included kinetic sub-sampling of both liquor and solids at two-, six-, 10-, 20-, and 24-hour intervals.

Significant improvement in Au recovery was observed on MC-2 and MC-3, compared to the coarse bottle roll leach tests. The CIL process is required on these composites to compete with the naturally occurring carbon.

##### Flotation Product Leach Tests

Four stirred leaches were conducted on concentrates from MC-2 and MC-3 flotation tests with and without carbon pre-flotation stages, to determine if any differences were observed in gold recovery in the concentrate leaching circuit. One stirred leach was conducted on a cleaner concentrate from MC-1 (CN-59).

No significant effect was observed from the carbon pre-flotation stage. The MC-1 cleaner concentrate leach produced good recovery.

In summary, 2022 cyanidation test work on the WMCP samples showed:

- / Gold recovery on master composite coarse ore bottle rolls ranged from 0.9% to 33%;
- / Gold recovery on master composite stirred CIL tests ranged from 55% to 85%; and
- / Gold recovery on variability CIL tests ranged from 3.8% to 93%.

Generally, composites with higher head grades had higher gold recovery.

120  
120

#### Full Circuit Flowsheet Testing

Two “full-circuit” flowsheets were tested on the MC-1 and MC-2/3 composites: gravity-cyanidation and gravity-flotation-cyanidation. Under the gravity-cyanidation flowsheet, the sample was ground to a p80 of 100µm, passed through a Knelson concentrator, and the Knelson concentrate was upgraded on a Super-Panner. The Knelson tails and Super-Panner tails were combined and transferred to a CIL bottle roll leach. For the gravity-flotation- cyanidation flowsheet the sample was ground to a p80 of 100µm, passed through a Knelson concentrator, and the Knelson concentrate was upgraded on a Super-Panner. The Knelson tails and Super-Panner tails were combined and transferred to flotation. The flotation concentrate was reground and transferred to a CIL stirred leach, and the flotation tails were forwarded to a CIL stirred leach without regrind.

Full circuit flowsheet test work indicated that combined gravity-cyanidation and gravity-flotation-cyanidation flowsheets both produced similar final recoveries. MC-1 gold recovery was 89% to 91% and MC-2/3 gold recovery was 74% to 76%.

The following recommendations were made for future test work:

- / Conduct further mineralogical analysis on the WMCP samples;
- / Determine gold deportment, particularly on samples with low recovery, with the purpose of diagnosing low gold recoveries and determining potential processing routes going forward; and
- / Conduct further variability test work to better delineate projected gold recovery on a spatial basis and provide inputs into the mine plan.

### 10.2.5 2023 WMCP EXTENSION PROGRAM BY BLUE COAST

Blue Coast was contracted by Hecla to execute a metallurgical test work program on material from the WMCP area of the Casa Berardi mine. The purpose of the 2023 test work program was to conduct mineralogical analysis and a flotation study on material from a previous WMCP metallurgical test work program. Past test work on WMCP samples had shown both a reduction in recovery and significant variability in recovery to the current Casa Berardi CIL process, ranging from 4% to 93% gold recovery. The average WMCP gold recovery of 67% is significantly lower than the average gold recovery from the Principal Pit (87%) and F160 Pit areas (92%). This reduced recovery was the driving factor to investigate alternative processing methods for the WMCP samples and to develop a fully integrated process flowsheet. Additionally, this program was intended to assess the response of four monthly Mill Feed composite samples in comparison to the standard Casa Berardi cyanidation conditions and to the flotation flowsheet.

#### 10.2.5.1 2023 SAMPLE PREPARATION AND ANALYSES

The fully integrated flowsheet would be developed on a new global WMCP master composite (WMCP Blend sample) formed from samples remaining from the 2022 WMCP Phase 2 Test Program. The final flowsheet would also be tested on a new Principal Pit blend composite, using material remaining from the 2021 Principal Pit Test Program and four monthly “Mill Feed” composites, representing material fed to the mill in January, February, March, and April 2022. Approximately 60kg of material from Casa Berardi was received in May 2022 by Blue Coast for sample preparation and analyses.

The WMCP blend composite was prepared by combining portions of MC-1, MC-2, and MC-3 at a ratio of 40% MC-1, 30% MC-2, and 0% MC-3 by weight. The material was homogenized and split into replicate test work charges.

121  
121

Six additional spatial variability composites were prepared, to assess variability across the deposit. Each variability composite was homogenized and split into replicate test work charges.

Each mill feed composite was screened at 10 mesh and any oversize material was stage crushed. Each composite was homogenized and split into replicate test work charges and head assay sub samples.

The Principal Pit blend composite was prepared by combining equal portions of MC1-LG, MC2-HG, and MC3-HS. The material was homogenized and split into replicate test work charges.

Head grades of the monthly Mill Feed composites are shown in Table 10-11.

**Table 10-11. 2023 Casa Berardi WMCP Master Composite Head Assays**

<b>Composite Rep.</b>	<b>Au (g/t) Average</b>	<b>As (%)</b>	<b>Fe (%)</b>	<b>S<sub>tot</sub> (%) Cut 1</b>	<b>S<sup>2-</sup> (%) Cut 1</b>	<b>C<sub>tot</sub> (%) Cut 1</b>	<b>C<sub>org</sub> (%) Cut 1</b>
Mill Feed – Jan 2022	1.86	0.49	7.07	2.12	1.79	1.88	0.12
Mill Feed – Feb 2022	1.78	0.64	6.79	1.80	1.57	2.05	0.15
Mill Feed – Mar 2022	1.75	0.61	7.84	2.44	2.20	2.37	0.18
Mill Feed – Apr 2022	1.88	0.69	7.89	3.03	2.83	2.41	0.23

In support of the flowsheet development, Blue Coast submitted unsized samples of MC-1 and MC-2/MC-3 (50:50 blend by weight) to The University of Western Ontario – Surface Science Western (SSW) in London, Ontario, Canada for analysis of solid solution gold in pyrite and arsenopyrite using Dynamic Secondary Ion Mass Spectrometry (D-SIMS) analysis and Ramen carbon analysis.

D-SIMS mineralogical analysis on WMCP samples showed that:

- / MC-1 contains approximately 23.9% sub-microscopic gold; 3.7% located in pyrite, and 20.2% located in arsenopyrite;
- / MC-2/3 blend contains approximately 69.3% sub-microscopic gold; 15.7% located in pyrite and 53.7% located in arsenopyrite; and
- / When broken down by morphology (coarse/porous/microcrystalline/disseminated):
  - » Pyrite - in both MC-1 and MC-2/3, the gold is primarily in the coarse (48% to 51%) and porous (31% to 36%) pyrite morphologies, with low gold in microcrystalline (13% to 14%) and disseminated (3% to 4%) particles; and
  - » Arsenopyrite - in both MC-1 and MC-2/3, the gold is primarily in the coarse (47% to 53%) and porous (29% to 30%) arsenopyrite morphologies, with low gold in microcrystalline (17% to 21%) and disseminated (1% to 2%) particles.

In both MC-1 and MC-2/3, the grade of gold contained in arsenopyrite is 48g/t to 49g/t, whereas the grade of gold in pyrite is 3.2g/t to 3.7g/t.

Based on the results of the D-SIMS analysis it was determined that the arsenopyrite minerals should be targeted for flotation, with the purpose of generating a concentrate that would not require leaching. This concentrate was anticipated to be blended with the gold concentrate produced in the previous flotation stage.

#### 10.2.5.2 FLOTATION TESTING

Based on the work conducted in prior test programs, combined with the mineralogy findings, the integrated flowsheet (shown in Figure 10-2) was developed to feature the following steps:

- / Carbon Pre-Float – a requirement on many samples in order to produce a saleable gold concentrate;
  - » Gold Reclaim from Carbon Concentrate – used to recapture gold and ensure minimal losses to carbon concentrate waste stream.
- / Gold Rougher – this gold rougher stage produces a high grade gold concentrate, prospectively for direct sale;
- / Arsenopyrite (AsPy) flotation – based on the D-SIMS analyses, it was anticipated that a gold-rich arsenopyrite concentrate could be produced with the optionality to add to the prospective gold concentrate or to add to the pyrite concentrate and leach;
- / Pyrite flotation – recover the remaining sulfide associated gold and subject to fine regrinding to liberate any small visible gold inclusions;
  - » Cyanide leaching of pyrite concentrate (via intensive leach), producing leached sulfide tailings; and
- / Cyanide leaching of flotation tailings, thus producing mainstream low sulfur tailings.

Figure STYLEREF 1 vs 10-. Flowsheet Originally Developed

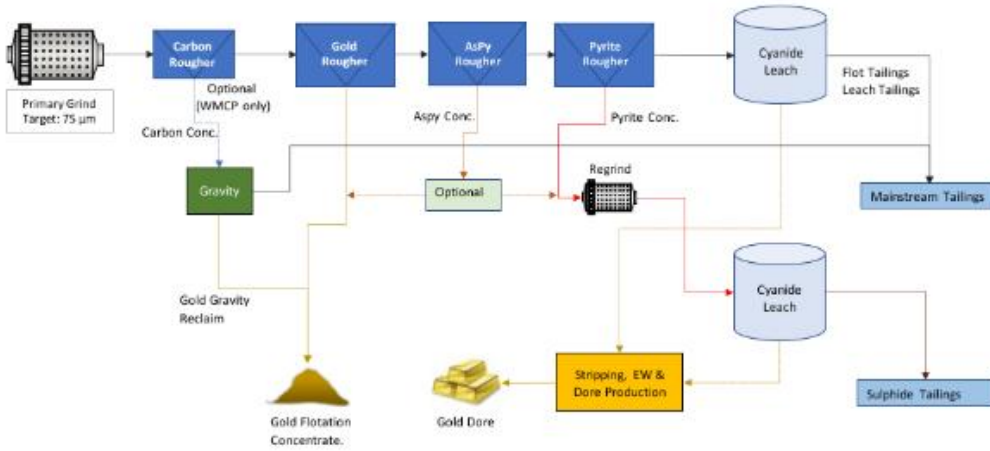

A total of 27 flotation tests were conducted throughout the program to explore and to optimize the various facets of the flotation stages. The key chemistry approach to flotation was as follows:

- / Carbon flotation performed with addition of Methyl Isobutyl Carbinol (MIBC) as a frother;
- / Gold flotation performed using 3418A (Aerophine) as a collector;
- / Arsenopyrite flotation conducted at pH 11.8 using copper sulfate as an activator and SIPX as a collector; and
- / Pyrite flotation conducted at pH 8 using H<sub>2</sub>SO<sub>4</sub>, using copper sulfate as an activator and PAX as a collector.

The initial conditions selected were based on the previous flotation test program work; the steps tested were cleaner circuit, carbon pre-flotation and a selective gold/arsenopyrite/pyrite flowsheet. Flotation conditions are shown in Table 10-12.

Table STYLEREF 1 \s 10-. Summary of 2023 Flotation Test Conditions

Test ID	Composite	Grind Size, p80 (µm)	Carbon Pre-float MIBC (g/t)	Au Ro/Cln		AsPy Ro/Cln			Pyrite Ro/Cln		
				3418A (g/t)	pH	CuSO <sub>4</sub> (g/t)	SIPX (g/t)	pH	CuSO <sub>4</sub> (g/t)	PAX (g/t)	pH
F-1	WMCP Blend	128	--	--	--	--	--	--	150	50/15/10/5	natural
F-2	WMCP Blend	126	73	10	10	400	20	11.8	150	80	8
F-3	WMCP Blend	100	73	7	10	--	--	--	150	80/25/20/15	8
F-4	WMCP Blend	109	73	7	10	--	--	--	150	80	8
F-5	WMCP Blend	98	73	7	10	400	20	11.8	150	80	8
F-6	WMCP Blend	101	36	7	10	--	--	--	150	80	8
F-7	WMCP Blend	65	73	7	10	--	--	--	150	80	8
F-8	WMCP Blend	59	36	7	10	400	20/10	11.8	150	80	8
F-9	Mill Feed – Jan 2022	76	73	7	10	400	20/10	11.8	150	80	8
F-10	Mill Feed – Feb 2022	84	73	7	10	400	20/10	11.8	150	80	8
F-11	Mill Feed – Mar 2022	83	73	7	10	400	20/10	11.8	150	80	8
F-12	Mill Feed – Apr 2022	82	73	7	10	400	20/10	11.8	150	80	8
F-13	WMCP Blend	~65	73	7	10	400	20/10	11.8	150	80	8
F-14	WMCP Blend	64	73	7	10	400	20/10	11.8	150	80	8
F-15	Mill Feed – Jan 2022	74	73	7	10	400	20	11.8	150	80	8
F-16	Mill Feed – Feb 2022	74	73	7	10	400	20	11.8	150	80	8
F-17	Mill Feed – Mar 2022	77	73	7	10	400	20	11.8	150	80	8

125  
125

Test ID	Composite	Grind Size, p80 (µm)	Carbon Pre- float MIBC (g/t)	Au Ro/Cln		AsPy Ro/Cln			Pyrite Ro/Cln		
				3418A (g/t)	pH	CuSO <sub>4</sub> (g/t)	SIPX (g/t)	pH	CuSO <sub>4</sub> (g/t)	PAX (g/t)	pH
F-18	Mill Feed – Apr 2022	79	73	7	10	400	20	11.8	150	80	8
F-19	Central Upper	64	--	7	10	400	20	11.8	150	80	8
F-20	Central Lower	59	73	7	10	400	20	11.8	150	80	8
F-21	West	74	73	7	10	400	20	11.8	150	80	8
F-22	East	82	73	7	10	400	20	11.8	150	80	8
F-23	Far West	74	73	7	10	400	20	11.8	150	80	8
F-24	Deep South	77	73	7	10	400	20	11.8	150	80	8
F-25R	Mill Feed Blend	84	--	7	10	--	--	--	150	80	8
F-26	WMCP Blend	70	32	7	10	--	--	--	150	80	8
F-27	Principal Pit Blend		--	7	10	--	--	--	150	80	8

126  
126

#### WMCP Blend – Flowsheet Development

The 2023 WMCP blend composite was used for the development of the flotation flowsheet. Initial tests were based on previously conducted flowsheet development for the 2022 WMCP Phase 2 Test Program.

The initial two tests compared a three stage cleaner (F-1) with the sequential carbon/gold/arsenopyrite/pyrite flotation flowsheet (F-2). The three stage cleaning flowsheet did not produce a concentrate meeting the minimum grade target (35g/t Au) and had very high sulfur content. The sequential flowsheet showed some success at removing organic carbon in the pre-flotation stage, and at producing a high grade gold concentrate (75g/t Au). The arsenopyrite stage showed the potential for refinement, and final pyrite stage recovered the remaining floatable gold.

The next test (F-3) refined the gold flotation circuit to a single stage and eliminated the arsenopyrite circuit in favor of producing a sulfide concentrate and cleaning in three stages. The cleaner 3 sulfide concentrate did not achieve a high gold grade and had very high sulfur grade. Tests F-4 and F-6 repeated this flowsheet, only to pyrite roughers, with the purpose of producing concentrate for cyanidation. An additional test (F-5) was conducted, which included the arsenopyrite circuit, with the purpose of concentrate cyanidation. A finer primary grind size was explored on F-7; the gold grade and recovery of the gold concentrate on this test increased, and losses to the rougher tail decreased. F-8 repeated this finer grind, with the inclusion of the arsenopyrite circuit. F-13 and F-14 were conducted as replicate tests of the F-8 flowsheet, with the purpose of producing concentrate and tailings material for further work.

Key findings from this flotation optimization program were:

- / Primary grind size is a key factor for increasing recovery to the gold rougher concentrate;
- / The sulfide concentrate does not clean readily and will require fine grinding and cyanidation to recover gold;
- / The carbon pre-flotation stage is effective at removing organic carbon, with limited gold losses; and.
  - » Removal of the organic carbon was key to making concentrate grade in the gold flotation circuit.

The inclusion of the arsenopyrite circuit was considered optional because:

- » Low arsenic recovery to this concentrate indicated little arsenopyrite was recovered, and any gold recovered were remnants of the gold flotation stage;
- » A decision was made to continue with the arsenopyrite flotation stage as that concentrate was directed to the prospective gold concentrate, instead of the cyanidation circuit; and
- » When the arsenopyrite circuit is not employed, the sulfide/pyrite circuit will collect any gold that would be typically recovered in the circuit. Elimination of the arsenopyrite circuit does not increase gold losses in the flotation circuits.

#### Application of WMCP Blend Flowsheet to Other Composites

The flowsheet developed on the WMCP blend was applied to each of the monthly Mill Feed composites, and a second test was conducted under refined targets for confirmation of best performance. Additionally, this flowsheet was applied to six composites prepared to represent spatial variability throughout the WMCP deposit.

Key findings from the application of the WMCP Blend flowsheet to other composites were:

- / Significant variability in response to the flowsheet was observed in the WMCP variability samples.
  - » Overall gold recovery to flotation concentrates with this flowsheet was highly variable, ranging from 24% (very high losses to carbon pre-flotation) to 90% (no carbon pre-flotation).

127  
127

- / The monthly Mill Feed composite samples responded consistently to the flowsheet.
  - » Gold losses to the carbon pre-flotation concentrate were fairly high. This pre-flotation stage was eliminated in the final flowsheet based on the testing of these samples.
  - » Gold recovery to the flotation concentrates (Au cleaner 1, arsenopyrite cleaner 1, pyrite rougher) ranged from 39% to 48%.

#### Final Flowsheet

The flotation optimization test work conducted on the WMCP blend resulted in the following final flowsheet (Figure 10-3):

- / Carbon pre-flotation (if organic carbon is greater than 0.3% in head grade)
- / Gold flotation
- / Sulfide (pyrite/arsenopyrite) flotation
  - » Forwarded to cyanidation
- / Rougher tails forwarded to cyanidation

128  
128

Figure STYLEREF 1 vs 10-. WMCP Blend Simplified Integrated Flowsheet

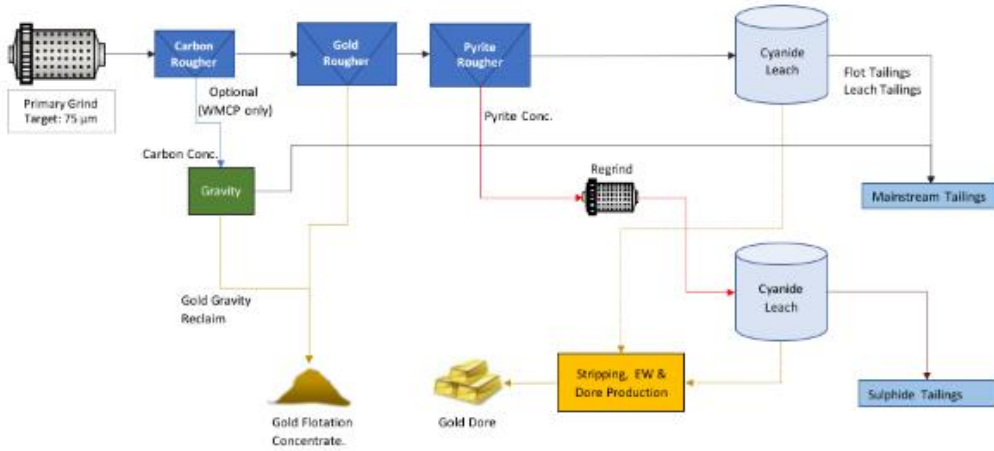

Flotation tests were conducted on blended samples to confirm the flowsheet performance on samples available from three separate areas of Casa Berardi (Mill Feed, WMCP, and Principal Pit).

### 10.2.5.3 2023 GRAVITY TESTING BY BLUE COAST

A total of four gravity recovery tests were conducted on whole ore, on each of the monthly Mill Feed composites. A 2kg sample of as-received material was passed through a laboratory Knelson MD-3 concentrator, the Knelson concentrate was collected and upgraded on a Super-panner. A tip, middling, and tail were collected from the Super-panner and a sub-sample of the Knelson tails and were assayed for gold. Gold recovery to the Knelson concentrate ranged from 40% recovery to 55% recovery.

The Super-panner was used successively three times on carbon pre-flotation material from WMCP Blend flotation tests to reclaim some of the gold that was lost to this product. From each test, a tip, middling and a Super-panner tail was collected and assayed for gold. These tests were highly successful at reclaiming gold from the carbon pre-flotation concentrate and rejecting carbon. The results showed that it was possible to reclaim a significant portion of the gold lost to a carbon pre-flotation concentrate, into a relatively low mass pull concentrate fraction.

### 10.2.5.4 2023 CYANIDATION TESTING BY BLUE COAST

A total of 29 cyanidation tests were conducted on whole ore, flotation concentrate, and flotation tails.

#### Whole Ore Cyanidation

A stirred leach was conducted on each of the monthly Mill Feed samples, under the standard Casa Berardi CIL conditions. A 1.0kg test charge was ground to 80% passing 75µm and leached at a solids content of 50%. All stirred leaches were conducted as CIL tests at an addition rate of 15.0g/L pulp with a 24-hour retention time. Sodium cyanide was maintained throughout the stirred leaches at a concentration of 1.0g/L of solution. Each stirred leach included kinetic subsampling of both liquor and solids at two-, six-, 10-, 20-, and 24-hour intervals.

Leach recoveries of the four composites were consistent with each other, ranging from 78.2% to 83.1% gold recovery.

#### Flotation Concentrate Cyanidation

A total of 15 cyanidation tests were conducted on flotation pyrite/sulfide concentrates, primarily from tests on the WMCP blend. Cyanidation conditions evaluated were cyanide concentration, pre-aeration with oxygen and lead nitrate addition. Samples were reground in a ceramic jar mill prior to leaching and leached at a solids content of 30%. All stirred leaches were conducted as carbon in leach (CIL) tests at an addition rate of 15.0g/L pulp with either 24 hour or 48 hour retention time. Conditions developed on the WMCP Blend concentrate samples were then applied to WMCP variability concentrates and Mill Feed Blend and Principal Pit concentrate samples.

Recoveries on the WMCP Blend pyrite concentrates were relatively consistent, averaging 60% Au recovery. Lead nitrate and oxygen pre-aeration were not found to increase recovery; however, increased cyanide dosage to 5g/L showed a 2% increase in recovery. This cyanide dosage was carried forward on future leaches. Residence time on future concentrate leaches was increased to 48 hours to ensure residence time was not limiting recovery. Cyanidation recovery on the WMCP Spatial Variability pyrite concentrate leaches (CN-18 to CN-23) showed significant variability in recovery, ranging from 34% to 71% gold recovery. The Mill Feed Blend pyrite concentrate leach (CN-27) was consistent with the WMCP Blend samples, and the Principal Pit Blend pyrite concentrate leach (CN-29) showed significantly higher recovery and was consistent with the Principal Pit Whole Ore leaches.

#### Flotation Tails Cyanidation

A total of ten cyanidation tests were conducted on flotation rougher tails. Conditions were consistent with the whole ore leach conditions and leached at a solids content of 50%. All rougher tails leaches were conducted as CIL tests at an addition rate of 15.0 g/L pulp with a 24-hour retention time. Sodium cyanide was maintained throughout the stirred leaches at a concentration of 1.0g/L of solution.

The WMCP spatial variability samples show variability in recovery, ranging from 42% to 86% gold recovery.

#### 10.2.5.5 COMBINED FLOWSHEET RECOVERY

The combined recovery of the flotation, pyrite concentrate cyanidation, rougher tails cyanidation, and carbon Super-panner gold reclaim (where applicable) is shown in Table 10-13 for the WMCP blend and WMCP spatial variability. Note for these samples the final flowsheet had not been used in the flotation test.

**Table STYLEREF 1 \s 10-. Combined Flowsheet Recovery – Non Final Flowsheet**

<b>Composite</b>	<b>WMCP</b>	<b>Central</b>	<b>Central Lower</b>	<b>West</b>	<b>East</b>	<b>Far West</b>	<b>Deep South</b>
Test ID	F-8	F-19	F-20	F-21	F-22	F-23	F-24
	CN-6	CN-18	CN-19	CN-20	CN-21	CN-22	CN-23
	CN-7	CN-12	CN-13	CN-14	CN-15	CN-16	CN-17
	GRG-SP-6	*	*	*	*	*	*
Overall Recovery (%)							
Prospective Gold Conc.	64.3	71.0	67.6	50.9	52.1	52.7	58.2
Leached Concentrate	14.2	14.1	6.0	15.1	16.5	10.0	14.8
Leached Tails	4.6	7.1	9.7	14.6	3.7	10.1	8.3
Total Gold Recovery (%)	83.1	92.1	83.3	80.6	72.3	72.9	81.3
Whole Ore CN Gold Recovery (%)	68.2	85.9	76.3	68.4	56.1	57.0	73.8
Gold Recovery Gain (%)	14.9	6.2	7.0	12.2	16.2	15.9	7.5

Note: \* Estimated based on WMCP Blend Test Work

Table 10-14 shows the overall recoveries from the tests conducted under the final flowsheet. The whole ore cyanidation recovery (at 75µm) for the same samples is listed for comparison, and the difference in recovery by the two processes is also shown. All samples tested showed a gain in gold recovery using the combined flotation, cyanidation, and gravity flowsheet compared to the whole ore cyanidation results. The recovery gain ranged from 5.5% to 10.3% increase.

**Table STYLEREF 1 vs 10-. Combined Flowsheet Recovery –Final Flowsheet**

Composite	Mill Feed Blend	WMC Blend	Principal Pit Blend
Test ID	F-25R	F-26	F-27
	CN-24	CN-25	CN-26
	CN-27	CN-28	CN-29
	N/A	GRG-SP-7	N/A
Overall Recovery (%)			
Prospective Gold Conc.	64.9	62.7	68.5
Leached Concentrate	16.4	13.3	21.8
Leached Tails	5.9	8.2	6.6
Total Gold Recovery (%)	87.1	84.1	97.0
Whole Ore CN Gold Recovery (%)	80.3	73.8	91.5
Gold Recovery Gain (%)	6.8	10.3	5.5

Application of the final flowsheet to blended WMCP, Principal Pit, and Mill feed samples resulted in total gold recoveries of:

- / Mill Feed Blend: 87.1% gold recovery;
- / WMCP Blend: 84.1% gold recovery; and
- / Principal Pit Blend: 97% gold recovery.

### 10.3 SULFIDE OPERATION DATA

Annual production from 2006 to 2023 is presented in Table 10-15.

**Table STYLEREF 1 \s 10-. Casa Berardi Annual Mill Production**

<b>Year</b>	<b>k Tonnes (kt)</b>	<b>Grade (g/t Au)</b>	<b>Recovery (%)</b>	<b>Metal Recovered (koz Au)</b>
2006	68	8.58	93.9	18
2007	545	9.78	93.0	159
2008	654	8.16	92.5	159
2009	689	7.77	92.6	159
2010	723	6.76	89.8	141
2011	698	8.00	91.3	164
2012	694	6.77	90.6	137
2013	591	6.16	90.5	106
2014	751	5.90	90.0	128
2015	766	5.96	87.2	128
2016	905	5.72	87.7	146
2017	1,176	4.77	86.8	157
2018	1,248	4.66	87.1	163
2019	1,250	4.10	81.5	134
2020	1,165	4.00	81.0	121
2021	1,386	3.56	84.8	135
2022	1,441	3.16	87.3	128
2023	1,312	2.51	85.2	90
Total	16,063	5.20	87.3	2,373

### 10.3.1 YEARLY REVIEW

Historic key operation parameters are presented in Table 10-16. The throughput has increased regularly since 2015 following improvements in the process.

133  
133

Table STYLEREF 1 \s 10-. Detailed Yearly Mill Production

Date	Dry k Tonnes Milled (kt)	Dry Tons/ Operating Hour (tph)	% Passing 200 mesh	Head Grade (g/t Au)	k Ounces Produced (koz Au)	Gravimetric Recovery (%)	Total Mill Recovery (%)	Cyanide Consumption (kg/t)	Mill Availability (%)
2015	766	96	86	5.960	128	35.3	87.2	0.82	95.2
2016	905	112	84	5.720	146	37.3	87.7	0.77	92.8
2017	1,176	153	75	4.770	157	37.1	86.8	0.67	88.9
2018	1,248	161	75	4.660	163	36.5	87.1	0.57	89.1
2019	1,250	162	72	4.100	134	26.4	81.5	0.54	88.6
2020	1,165	168	71	4.000	121	34.3	81.0	0.48	86.1
2021	1,386	178	74	3.560	135	36.7	84.8	0.54	89.7
2022	1,441	193	78	3.160	128	42.5	87.2	0.51	91.3
2023	1,200	184	77	2.550	84	32.0	85.2	0.52	93.0

134  
134

## 10.4 RECOVERY MODELS

### 10.4.1 UNDERGROUND (ZONES 115/118/121/123/148)

The historical recovery model provides a good indication of the expected performance in the mill. It should be noted that all recovery calculations are performed with data presented in metric units. With the measurement of arsenic content, it is possible to have a more accurate estimation of gold recovery. Two recovery models were obtained and are defined by the following equations:

/ Low Arsenic

Gold recovery  $\% = 0.9753 \times \text{Au head grade} - 0.4287 \text{Au head grade}$

/ High Arsenic

Gold recovery  $\% = 0.9918 \times \text{Au head grade} - 0.7723 \text{Au head grade}$

The decision to fit the appropriate model to each zone is approved and verified by a Hecla geologist. The data used to compute the model is derived from the actual mill performance. As such uncertainty regarding mill feed variability is reduced because the data covers many months of operation. Therefore, the results from previous metallurgical testing are not used to predict the recovery for the underground ore.

### 10.4.2 OPEN PIT

For the open pit gold recovery used in the LOM, the data is based on available metallurgical test work results reported by Blue Coast in 2023.

#### 10.4.2.1 F134/PRINCIPAL PIT

The same equation for recovery as presented for the EMCP/XCMP Pit material is used for the F134/Principal Pit material, as no results from the work conducted by Blue Coast 2021 were available at the time of writing. The SLR QP is confident that the information below will provide a good estimation of the expected recovery in the LOM plan.

Gold recovery  $\% = 0.942 \times \text{Au head grade} - 0.35 \text{Au head grade}$

#### 10.4.2.2 F160 PIT

The metallurgical test work was completed at Blue Coast in 2020 using representative samples with different grind sizes, head grades, and with dilution to simulate near a real situation in the pit. The SLR QP considers that the information below provides a good estimate of the expected recovery in the LOM plan and the confidence is appropriate for the precision required.

Gold recovery  $\% = 0.9311 \times \text{Au head grade} - 0.07994 \text{Au head grade}$

#### 10.4.2.3 WMCP PIT

The metallurgical test work was completed using representative samples with different grind sizes, head grades, and with dilution to simulate a real situation in the WMCP Pit. The SLR QP considers that the equation below provides a good estimate on the expected recovery in the LOM plan and the confidence is appropriate for the precision required.

Gold recovery  $\% = 0.8365 \times \text{Au head grade} - 0.2293 \text{Au head grade}$

135  
135

## 10.5 EXPECTED RECOVERIES

The expected recoveries from the different open pits are summarized in Table 10-17.

**Table 10-17. Expected Recovery LOM for all Mining Zones**

Zone	Expected Recovery	LOM Grade
	(%)	(g/t Au)
F134 Pit	84.5	3.61
F160 Pit	88.7	1.80
WMCP Pit	75.9	2.96
Principal Pit	83.0	3.12

## 10.6 DELETERIOUS ELEMENTS

There are two deleterious elements that could potentially affect the process:

- / Arsenic: Ferric sulfate is added to precipitate arsenic in the tailings pond; and
- / Carbon: The carbon in the ore could cause preg-robbing and affect the gold recovery.

## 10.7 CONCLUSIONS AND RECOMMENDATIONS

The test work performed on open pit material was used to estimate the gold recovery, while operating data was used for the underground material.

The SLR QP recommends that the following metallurgical test work continue, as appropriate to understand ore variability and process risk:

- / Additional metallurgical testing to better understand the processing of mineralization from the Principal and WMCP pits. This will aid in projecting metallurgical recoveries for these pits and will indicate any variability in gold recovery and grindability of the material.

Test work programs, both internal and external, continue to be performed to support current operations and potential improvements.

The SLR QP has reviewed the information provided by Hecla, as summarized in Section 10.0, and has performed a review of the reconciliation data available to verify the information used in the LOM plan. Based on these checks, in the opinion of the SLR QP, the metallurgical test work, reconciliation, and production data support LOM planning:

- / Industry standard and appropriate metallurgical testing procedures consistent for the deposit's mineralogy have been consistently used by Hecla staff for optimizing and improving mill process capabilities and performance;

- / Numerous external and internal studies have been conducted to the date of this TRS, which have been used to develop and optimize the existing flowsheet;
- / The samples used in the test work are considered representative of mill feed types across the Casa Berardi deposits;
- / LOM projections are based on production results and informed by metallurgical test data that is updated in the model forecasts annually;
- / Mill metallurgical results and forecasts are consistent with the deposit mineralogy and the process circuit used; and
- / Metallurgical and production models were developed from metallurgical sampling and testing. The methodologies, process, and data used in making recovery projections are unbiased and provide reliable projections.

137  
137

RSI-M0206.22001

---

# 11.0 MINERAL RESOURCE ESTIMATES

## 11.1 SUMMARY

Mineral Resource estimates for the Casa Berardi Mine as of December 31, 2023, are presented in Table 11-1 and Table 11-9. Total Measured and Indicated Mineral Resources, exclusive of Mineral Reserves, are estimated to be 4.11Mt at 6.39g/t Au containing 0.84Moz Au. Inferred Mineral Resources total 2.09Mt at 5.89g/t Au for 0.40Moz Au. The underground portion of the Measured and Indicated Mineral Resources represents 94% of the total.

Casa Berardi Mineral Resources were estimated using block model grade interpolation techniques, effectuated by the mine staff. The classification of Casa Berardi Mineral Resources considers the quality of drill hole data, the continuity of auriferous zones, drill-hole spacing (which ranges from 15m to 50m), and production experience. The Casa Berardi Mineral classification is applied using polygons that are modeled based on the proximity of block centroids relative to drill-hole composites and mine workings. Mineral Resources are classified in accordance with the definitions and requirements set by the SEC in S-K 1300 (SEC, 2018). The Mineral Resources were classified as follows:

- / **Measured Mineral Resources:** Blocks in modeled mineral envelopes within a mean distance of ~25m and ~35m for underground and open pit material, respectively, and underground or surface development within close proximity that supports the continuity of mineralization.
- / **Indicated Mineral Resources:** Blocks in modeled mineral envelopes within a mean distance of ~25m and ~35m for underground and open pit material, respectively, that are not Measured Mineral Resources.
- / **Inferred Mineral Resources:** Blocks in modeled mineral envelopes outside a mean distance of ~25m and ~35m for underground and open pit material, respectively. The mean distance of underground Inferred Mineral Resources is generally between 25m and 35m, and rarely up to 50m. The mean distance of open pit Inferred Mineral Resources is generally 60m or less.

The locations of the Casa Berardi Mineral Resource areas are shown in Figure 11-1, and Mineral Resources as of December 31, 2023, are summarized in Table 11-9.

Figure STYLEREF 1 \s 11-. Mine Plan View and Composite Longitudinal Section of Deposit Areas and Infrastructure  
 (from Hecla, 2023)

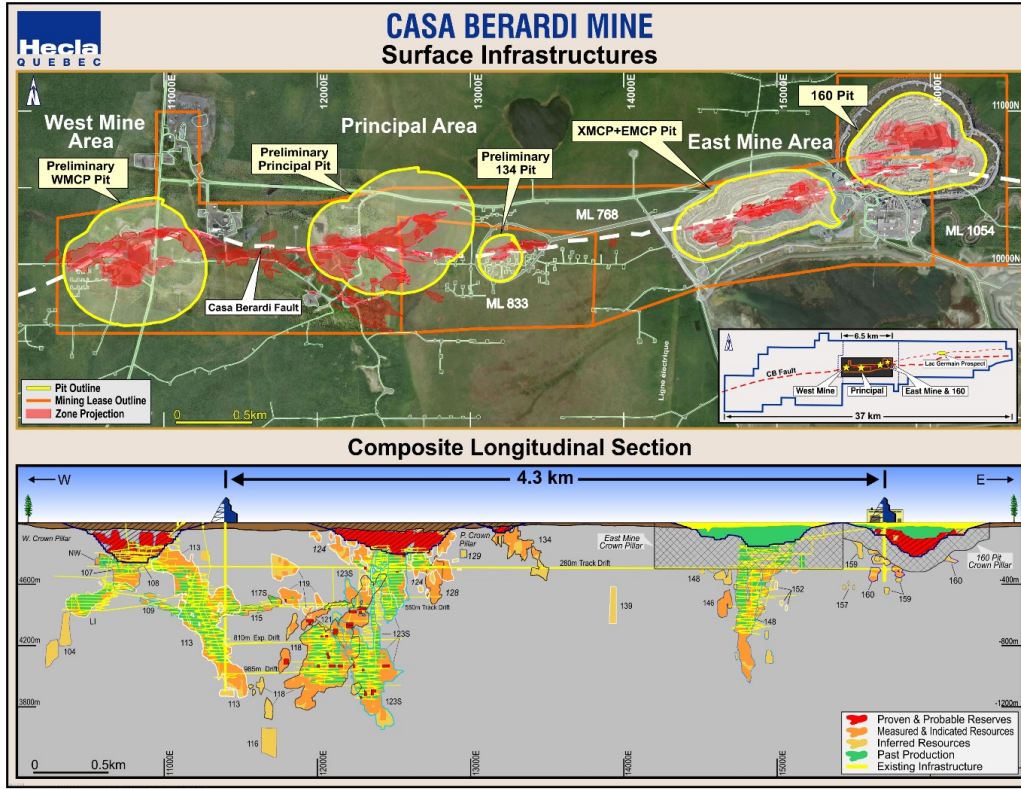

139  
 139

**Table STYLEREF 1 \s 11-. Casa Berardi Mineral Resource Estimate Summary – December 31, 2023**

Resource Category	K Tonnes	Grade (g/t Au)	Contained Metal (k oz Au)
Underground			
Measured	997	7.30	234.0
Indicated	2,861	6.55	602.5
Measured and Indicated	3,858	6.74	836.6
Inferred	1,338	7.71	331.6
Open Pit			
Measured	61	0.96	1.9
Indicated	186	0.81	4.9
Measured and Indicated	247	0.85	6.7
Inferred	751	2.65	64.0
Total			
Measured and Indicated	4,106	6.39	843.3
Inferred	2,089	5.89	395.6

Notes:

1. In situ Mineral Resources are classified in accordance with the S-K 1300 classification system.
2. Mineral Resources were estimated by Hecla staff and reviewed and accepted by RESPEC.
3. Mineral Resources are exclusive of Mineral Reserves and do not have demonstrated economic viability.
4. Underground Mineral Resources are reported at cutoff grades ranging from 3.78g/t Au to 5.84g/t Au.
5. Open pit Mineral Resources are reported at cutoff grades ranging from 0.97g/t Au to 1.13g/t Au.
6. Underground and open pit Mineral Resources are reported using US\$1,750/oz Au, based on consensus, long term forecasts from banks, financial institutions, and other sources, and a US\$/C\$ exchange rate of 1.300.
7. A minimum mining width of three meters was used for the modeled open pit and underground mineral envelopes used to estimate Mineral Resources.
8. Totals may not represent the sum of the parts due to rounding.
9. Mineral Resources potentially amenable to open pit mining methods are reported using a gold price of US\$1,750/oz, a throughput rate of 4,400 tonnes/day (combined material from underground and open pit sources), surface mining costs of US\$3.46/tonne mined, milling processing costs of US\$24.13/tonne processed, and general and administrative and other costs ranging from \$9.96-10.34/tonne processed. Metallurgical recoveries were based on metallurgical curves.
10. Mineral Resources potentially amenable to underground mining methods are reported using a gold price of US\$1,750/oz and a throughput rate of 4,400 tons/day (combined material from underground and open pit sources). Operating costs are US\$183.08/ton mined or US\$282.60/ton mined, depending on the underground zone or lens. Mill recoveries also vary by zone or lens and range from 80.10% to 89.90%.

Open pit Mineral Resources are reported within optimized pits using the parameters summarized in Table 11-2.

**Table STYLEREF 1 \s 11-. Open Pit Optimization Parameters Applied to Mineral Resources**

Item	F160	Principal	WMCP	F134	Unit
Mining Cost Surface	\$3.46	\$3.46	\$3.46	\$3.46	\$/tonne
Milling Processing cost	\$24.13	\$24.13	\$24.13	\$24.13	\$/tonne processed
Process rate	4,400				tonnes-per-day processed
General and Administrative and other cost	\$10.34	\$9.96	\$10.02	\$9.96	\$/tonne processed
Au price	\$1,750	\$1,750	\$1,750	\$1,750	\$/oz
Au COG recovery	84.9	63.2	63.3	63.2	percent

Underground Mineral Resources are reported by tabulating all blocks within modeled mineral envelopes with estimated grades that exceed the calculated reporting cutoff grade for a given zone or lens (sub-zone). Sterilized ground, including pillars and buffer zones below the bottom of pits, are excluded from Mineral Resources. The cutoff grades used by Hecla for reporting underground Mineral Resources are calculated by the following equations:

- / Revenue per unit gold:  $US\$1,750/\text{oz Au} \div 31.10348\text{g}/\text{oz Au} = US\$56.26/\text{g} \times \text{Mill recovery}$
- /  $\text{Cutoff grade} = \text{Operating costs} / \text{Revenue per unit gold}$ . Table 11-3 provides a summary of the differences between the December 31, 2023, and December 31, 2022, Mineral Resource estimates. Gains and losses are a result of:
  - / Geological reinterpretation of mineralized zones with new drilling.
  - / Conversion of Mineral Resources into Mineral Reserves.
  - / Mining depletion.
  - / Subtraction of low-grade Mineral Resources (below cutoff grade).
  - / Lower reporting cutoff grades in 2023.
  - / Changes in pit optimization parameters, e.g. mining costs, administrative costs, etc.
  - / Change in reporting gold price from \$1,700/oz to \$1,750/oz.
  - / Dilution applied to open pit optimizations was lowered in 2023.
  - / Sterilization beneath the planned pits was applied to underground resources.
  - / Open pit designs were used to constrain Mineral Resources in 2023 rather than optimizations, which were used in 2022.
  - / Apparent gains and losses by upgrade of Inferred or Indicated Mineral Resources to Indicated or Measured Mineral Resources.

**Table STYLEREF 1 \s 11-. Comparison of December 31, 2023 Versus December 31, 2022 Mineral Resources**

	December 31, 2023			December 31, 2022			Gain (Loss)	
	K Tonnes	Grade (g/t Au)	Contained Metal (K oz Au)	K Tonnes	Grade (g/t Au)	Contained Metal (K oz Au)	K Tonnes	Ounces (K oz Au)
Measured								
Total Underground	997	7.30	234.0	2,440	5.08	530.2	(1,340.5)	(296.1)
Total Open Pit	61	0.96	1.9	438	1.39	19.5	(377.1)	(15.6)
Total Measured	1,058	6.94	235.9	2,878	6.45	549.7	(1,717.6)	(313.7)
Indicated								
Total Underground	2,861	6.55	602.5	3,511	5.85	659.9	(649.9)	(57.4)
Total Open Pit	186	0.81	4.9	1,200	1.24	47.8	(1,014)	(43.0)
Total Indicated	3,048	6.20	607.4	4,711	4.67	707.8	(1,664)	(100.4)
Measured and Indicated								
Total Measured and Indicated	4,106	6.39	843.3	7,589	5.31	1257.5	(3,381)	(414.1)
Inferred								
Total Underground	1,338	7.71	331.6	2,015	6.64	430.4	(676.6)	(98.8)
Total Open Pit	828	2.65	64.0	7,828	1.71	389.4	(6,351)	(325.4)
Total Inferred Mineral Resources	2,303	5.89	395.6	10,049	2.80	819.8	(7,028)	(424.2)

Notes:

1. The 2022 Mineral Resources are superseded by the current 2023 Mineral Resources and are not relied upon by Hecla or RESPEC. RESPEC has not reviewed the 2022 Mineral Resource models or estimates.
2. The 2023 Mineral Resources are entirely attributable to Hecla.
3. In situ Mineral Resources are classified in accordance with the S-K 1300 classification system.
4. Mineral Resources were estimated by Hecla staff and reviewed and accepted by RESPEC.
5. Mineral Resources are exclusive of Mineral Reserves and do not have demonstrated economic viability.
6. Underground Mineral Resources are reported at cutoff grades ranging from 3.78g/t Au to 5.84g/t Au.
7. Open pit Mineral Resources are reported at cutoff grades ranging from 0.97g/t Au to 1.13g/t Au.
8. Underground and open pit Mineral Resources are reported using US\$1,750/oz Au, based on consensus, long-term forecasts from banks, financial institutions, and other sources, and a US\$/C\$ exchange rate of 1.300.
9. A minimum mining width of three meters was used for the modeled open pit and underground mineral envelopes used to estimate Mineral Resources.
10. Totals may not represent the sum of the parts due to rounding.

11. Mineral Resources potentially amenable to open pit mining methods are reported using a gold price of US\$1,750/oz, a throughput rate of 4,400 tonnes/day (combined material from underground and open pit sources), surface mining costs of US\$3.46/tonne mined, milling processing costs of US\$24.13/tonne processed, and general and administrative and other costs ranging from \$9.96-10.34/tonne processed. Metallurgical recoveries were based on metallurgical curves.
12. Mineral Resources potentially amenable to underground mining methods are reported using a gold price of US\$1,750/oz and a throughput rate of 4,400 tons/day (combined material from underground and open pit sources). Operating costs are US\$183.08/ton mined or US\$282.60/ton mined, depending on the underground zone or lens. Mill recoveries also vary by zone or lens and range from 80.10% to 89.90%.

## 11.2 DATABASE

The current Mineral Resource estimate is based on data available as of June 18, 2023. The drill-hole and rock-chip assay database structures are detailed in Appendix 2. Collar, down-hole survey, assay, and geology data from Hecla Québec/Aurizon, Inco Gold, and TVX were merged into the database from files from various sources.

Four companies have conducted exploration and delineation drilling programs in the Casa Berardi deposit areas since 1957, including Hecla, which began drilling in late 2013 following its acquisition of the property from Aurizon. In all, 16,486 holes totaling 2,541,144m have been drilled (Table 11-4). Holes drilled or with assays received after the effective date of the database are not included in the table. These drill holes, as well as Hecla's property limits and the Casa Berardi mineral resource outlines, are shown in Figure 7-1. Core drill holes account for 84.4% of the meterage drilled. RC and sonic holes represent only 0.5% and 0.6%, respectively, of the total project database.

**Table 11-4. Summary of Core, Reverse Circulation and Sonic Drill Holes and Channel Samples at Casa Berardi**

Hole or Sample Type	Count	Meters
Core	13,917	1,959,133
RC	2,469	74,943
Sonic	103	3,401
Total Drilling	16,489	2,037,477
Channel Samples	14,747	106,770

Table 11-5 presents descriptive statistics of all Casa Berardi drill-hole analytical sample data compiled into the SQL database by Hecla. Measured density and core geotechnical data are also summarized. Rejected sample assay data have been excluded from the table. Trace element and whole-rock geochemical data have also been provided by Hecla but are not shown in Table 11-5.

**Table STYLEREF 1 \s 11-. Descriptive Statistics of Sample Assays in Casa Berardi Drill-Hole Database**

(accepted sample data only)

	Valid Values	Median	Mean	Standard Deviation	Coefficient of Variance	Minimum	Maximum	Units
From	1,032,621					0.00	2884	m
To	1,032,621					0.02	2885	m
Length	1,032,621	1.00	1.16			0.00	377	m
Au	1,006,534	0.040	1.014	5.936	5.856	0.00	1170	ppm
Ag	45,467	0.00	0.15	2.46	15.90	0.00	267	ppm
Density	7,917	2.74	2.77	0.24	0.09	0.01	4.6	g/cm3
Recovery	40,795	100.00	99.84	3.06	0.03	0.00	110	%
RQD	540,623	83.33	70.93	32.43	0.46	0.00	7,000	%

The Casa Berardi database contains 1,006,534 accepted gold assay records (Table 8-4). Only 45,467 (4.5%) of the accepted gold assay samples were analyzed for silver, although the grade of silver is generally too low to potentially contribute significantly to the economics of the mine.

At the stope-delineation stage, the locations of historical holes are being redrilled to validate the assay data in the older holes. Any assay or sample data determined to be imprecise compared to the new drill holes are excluded from use in Mineral Resource and Reserve estimation. Some assays were also removed from the database due to QA/QC failures, although the associated samples were generally re-assayed and replaced when necessary as determined by Hecla staff. Chip samples collected underground have been used for underground resource estimates but are excluded from open pit resource estimates.

Hecla entered collar, down-hole survey, geology and assay data into the drill-hole database and performed various verifications to ensure the data was correctly compiled. RESPEC conducted independent verification of gold assay data for the years 2021, 2022 and 2023 only.

### 11.3 DENSITY DETERMINATION

From 1991 to 1997, TVX used a single density of 2.77t/m<sup>3</sup> for Mineral Reserve estimation and the mill operation. Since 1999, several density testing programs have been carried out. Density determinations were conducted on sections of whole core prior to crushing for assaying using the water immersion method. Since rocks at Casa Berardi are non-porous, no wax coating was applied to core samples. Density measurements were obtained at various laboratories, including Swastika, SGS and the mine's laboratory, and samples were selected to represent mineralized and non-mineralized rock and various lithologies. Samples for density measurements were taken from most of the mineralized lenses. The density database contains approximately 7,914 records, including a total of 3,151 that were taken within the mineralized lenses (lenses are essentially sub-zones within each open pit and underground numbered zone) containing resources and reserves.

144  
144

Table 11-6 presents a summary of the density determinations by zone. Where there is a variable grade range applied to the block model, individual lenses within the given zone were assigned unique density values.

**Table STYLEREF 1 \s 11-. Density Determinations by Zone**

<b>Open Pit Zone</b>	<b>Number</b>	<b>Density Range Applied to Block Model (t/m<sup>3</sup>)</b>	<b>Mean (t/m<sup>3</sup>)</b>	<b>Minimum (t/m<sup>3</sup>)</b>	<b>Maximum (t/m<sup>3</sup>)</b>
105	46	2.77	2.68	2.57	2.84
123	29	2.70-2.85	2.78	2.57	3.10
124	472	2.69-2.95	2.83	2.35	3.73
134	39	2.7	2.66	2.19	3.47
146	46	2.8	2.68	2.55	2.80
148	200	2.8	2.68	2.13	2.99
152	47	2.8	2.77	2.55	2.93
159	19	2.72	2.77	2.66	2.97
160	333	2.72	2.69	2.38	3.03
Total	1,231		2.74	2.13	3.73
<b>Underground Zone</b>	<b>Number</b>	<b>Density range Applied to Block Model (t/m<sup>3</sup>)</b>	<b>Mean (t/m<sup>3</sup>)</b>	<b>Minimum (t/m<sup>3</sup>)</b>	<b>Maximum (t/m<sup>3</sup>)</b>
100 ( Lower Inter ),104	50	2.7	2.67	2.51	2.92
107 ,108	15	2.77	2.69	2.58	2.84
109	106	2.72	2.72	2.55	3.04
113	449	2.7-2.77	2.73	2.37	3.78
115	115	2.75	2.67	2.16	2.99
118	429	2.7-2.87	2.38	2.51	4.15
119	82	2.7	3.01	2.59	4.6
121	93	2.77	2.86	2.52	4.31
123	226	2.7-2.85	2.89	2.46	4.17
124	241	2.69-2.95	2.86	2.35	3.45
146,148	4	2.7-2.77	2.61	2.56	2.64
152,157	5	2.7-2.77	2.83	2.78	2.87
159,160	88	2.72	2.70	2.45	3.03
Total	1,920		2.79	2.16	4.6

Total Open Pit and Underground	3,151		2.77	2.13	4.6
--------------------------------	-------	--	------	------	-----

## 11.4 GEOLOGICAL INTERPRETATION

Hecla performed geological interpretation of overburden material and the Casa Berardi Fault on 1:250 scale vertical sections spaced 15m, 20m, 25m, or 50m, apart and on plan views spaced 10m and 20m apart. Individual mineral zones and lenses (sub-zones) were also modeled within and along the Casa Berardi Fault and related mineralized zones. Drill-hole spacing ranges from 10m to 50m. In general, the drill-hole spacing is sufficiently dense to interpret and correlate the geology and mineralized systems from section to section. Underground drill spacing is denser than for open pit models, so underground zones and lenses could be correlated with more confidence. Drill holes and chip sample data, along with underground mapping, were used to build individual lens solids. Once modeled, the lenses were projected onto multiple levels to verify continuity and to check interpretations. Adjustments on sections and plans were made, as necessary, in order to consistently interpret a given zone or lens through a set of sections and plans.

## 11.5 MINERALIZED ENVELOPE INTERPRETATION

For underground Mineral Resource estimation, Hecla created mineralized envelopes that coincide with a 4.0g/t Au grade shell and were based on logged structural zones. A generalized 1.0g/t Au envelope was created to constrain open pit Mineral Resource estimation. In both cases, a minimum true width of three meters was applied to the solid modeling, and points on the solids were snapped to intended drill-hole intervals in three-dimensional space. Some lower-grade assays were incorporated to preserve continuity; however, most of the assay results from drill holes and chips samples are higher than the envelope grades. Additional 10m dilution shells were also created outside the open pit mineral envelopes to estimate dilutionary grades. Geological and zone/lens interpretations guided mineralized envelope modeling.

Mineralization is commonly stratigraphically constrained, and sharp contacts between economic and non-economic grades are noted. The open pit Mineral Resource envelopes are always wider and can contain several underground envelopes. The open pit Mineral Resource envelopes are generally modeled from surface to a depth of 350m while the underground Mineral Resources are modeled from surface with no lower limit.

## 11.6 CAPPING AND COMPOSITING

Grade capping was applied to minimize the impact of excessively high-grade assays on the Mineral Resource estimate. Each zone or lens within given zones were evaluated separately and assigned appropriate capping values. Statistical distributions of assays within the mineralized envelopes were plotted on histograms and used to evaluate capping levels. Capping levels were applied to assays prior to compositing Figure 11-1 Open pit and underground capping levels applied to assays used in the various estimates are summarized in Appendix 3. Within the 10m pit dilution shells in the open pit models, a capping value of 1.5g/t Au was applied to avoid detrimental effects from isolated high-grade values outside the 1.0g/t Au mineralized envelope.

After validation of the gold mineralized envelope solids and capping of sample assays, the drill-hole assay data was composited. The down-hole composite length applied to samples used for underground and open pit estimation is 1.0m and 2.5m, respectively. The underground composite length was chosen because the majority of sample intervals in underground drilling is 1.0m. The open pit composite length was chosen to reflect the smallest mining unit (SMU) based on equipment being used in current open pit mining; the model block dimensions were also considered. Mineral envelope solid boundaries were honored during compositing, and composite data were stored at the midpoints of the intervals. Partial composite slivers were weight averaged with the adjacent 1m or 2.5m composites or left as a single composite such that composite lengths are always between 0.5m and 1.5m for underground and between 1.25m and 3.75m for open pit models.

Only drill-hole and rock-chip chips samples taken from the pits were composited for use in grade estimation in the open pit block models. There is a high-grade sample-selection bias incorporated in the underground rock-chip samples which could cause over-statement of gold grades within the relatively broad open pit mineralized envelopes.

A separate set of composites were created that represent the full interval length within each mineralized lens. These were generated for use in statistical evaluations, including the determination of capping values for gold assays. The second set of composites were not used in Mineral Resource or Reserve estimation.

## 11.7 BLOCK MODEL DIMENSIONS AND CODING

The block dimensions for the Principal, East, and 160 underground block models are 2.5m (column) x 1.25m (row) x 5.0m (vertical). The models were sub-blocked to 1.25m x 0.625m x 2.5m. The block dimensions for the West mine model are 2.5m x 1.25m x 2.5m (sub-blocked to 1.25m x 0.625m x 1.25m), because the veins in the 109 and 115 zones are relatively shallow dipping.

The most recent updates of the open pit block models were created in Gemcom software, then exported to Surpac and sub-blocked. The block size for the WMCP and 160 open pit models is 2.5m<sup>3</sup> and is sub-blocked to 0.625 m<sup>3</sup>. The block dimensions for the Principal block model are 5m x 5m x 7.5m and are sub-blocked to 0.625m x 0.625m x 0.937m. The block size for the Principal model was increased because the model size was excessive with the addition of the 134 Zone.

After validation of the various modeled wireframes, items in the block model were coded using their respective solids and surfaces. These included the overburden material (combined till and alluvium), topography, bedrock, clay zones, mineral zones and lenses, the 1.0g/t Au open pit and 4.0g/t Au underground mineralized envelopes, and the 10m open pit dilutionary envelope. All coding was by majority volume within each individual sub-block; no percentages within individual sub-blocks were coded from solids or surfaces. Open pits were also coded into the model by majority in a sub-block once optimizations were complete. Density values were assigned to model blocks according to Table 11-2 in Section 11.3.

Hecla's engineering department used a Cavity Monitoring System (CMS) to survey the extents of mined-out stopes. These cavity surveys were combined with previous stope and underground development solids, and sub-blocks in the Surpac model were coded as depleted or not depleted. The coded voids in the underground and open pit block models were used for engineering and reconciliation studies, and for reporting depleted Mineral Reserves and Resources. Pillars, buffer zones below open pits, and other sterilized areas that are deemed to be non-recoverable

147  
147

were coded to prevent their inclusion in reported Mineral Resources. Optimized pit shells and/or pit designs were applied to the model as resource and reserve codes.

## 11.8 MINERAL RESOURCE ESTIMATION METHODOLOGIES

Surpac 2023 HF 1(x64) was used for the preparation of Mineral Resources. Gold grades were estimated into the block models using inverse distance squared ( $ID^2$ ) interpolation. Spherical search ellipsoids and distances were applied to mineralized envelopes individually. A total of 232 and 64 search ellipsoids were used to interpolate the underground and open pit Mineral Resources, respectively. Maximum search distances in the underground estimates range from 15m to 100m, and from 35m to 60m in the open pit estimates. Search anisotropies vary from 1:1 (spherical) to 6:1. Minimum composites required, maximum composites per hole, and maximum composites used to estimate a block grade were 2, 3 or 6, and 12 or 24 for the underground models, and 2 or 3, 3, and 24 for the open pit models. The mean anisotropic distances to composites used to estimate a given block grade, and the number of composites used were stored during the interpolation runs and were used for resource classification. Arsenic grades were also interpolated using XRF data, where available.

Base elevation levels were established for the open pit models, below which no grade was estimated. The lower limits were 4,677ft AMSL, 4367ft AMSL, and 4,552ft AMSL for the WMCP, Principal/F134, and F160 pit areas, respectively.

## 11.9 MINERAL RESOURCE VALIDATION

Hecla personnel conduct on-screen visual inspection of estimated gold grades in the block model in context with diamond drill-hole assays and composites on plans and vertical sections. Multiple iterations of interpolation were run with modified estimation parameters until issues, such as unestimated blocks, were corrected and the distribution of gold grade in the model was considered satisfactory.

## 11.10 MINERAL RESOURCE CLASSIFICATION

Definitions for Mineral Resource categories used in this TRS are those defined by the SEC in S-K 1300 and excerpted below. Mineral Resources were classified into Measured, Indicated, and Inferred categories.

**Mineral Resource** is a concentration or occurrence of material of economic interest in or on the Earth's crust in such form, grade or quality, and quantity that there are reasonable prospects for economic extraction. A Mineral Resource is a reasonable estimate of mineralization, considering relevant factors such as cutoff grade, likely mining dimensions, location or continuity, that, with the assumed and justifiable technical and economic conditions, is likely to, in whole or in part, become economically extractable. It is not merely an inventory of all mineralization drilled or sampled.

**Measured Mineral Resource** is that part of a Mineral Resource for which quantity and grade or quality are estimated on the basis of conclusive geological evidence and sampling. The level of geological certainty associated with a Measured Mineral Resource is sufficient to allow a QP to apply modifying factors, as defined in this section, in sufficient detail to support detailed mine planning and final evaluation of the economic viability of the deposit. Because a Measured Mineral Resource has a higher level of confidence than the level of confidence of either an

148  
148

Indicated Mineral Resource or an Inferred Mineral Resource, a Measured Mineral Resource may be converted to a Proven Mineral Reserve or to a Probable Mineral Reserve.

**Indicated Mineral Resource** is that part of a Mineral Resource for which quantity and grade or quality are estimated on the basis of adequate geological evidence and sampling. The level of geological certainty associated with an Indicated Mineral Resource is sufficient to allow a QP to apply modifying factors in sufficient detail to support mine planning and evaluation of the economic viability of the deposit. Because an Indicated Mineral Resource has a lower level of confidence than the level of confidence of a Measured Mineral Resource, an Indicated Mineral Resource may only be converted to a Probable Mineral Reserve.

**Inferred Mineral Resource** is that part of a Mineral Resource for which quantity and grade or quality are estimated on the basis of limited geological evidence and sampling. The level of geological uncertainty associated with an Inferred Mineral Resource is too high to apply relevant technical and economic factors likely to influence the prospects of economic extraction in a manner useful for evaluation of economic viability. Because an Inferred Mineral Resource has the lowest level of geological confidence of all Mineral Resources, which prevents the application of the modifying factors in a manner useful for evaluation of economic viability, an Inferred Mineral Resource may not be considered when assessing the economic viability of a mining project and may not be converted to a Mineral Reserve.

The classification of the Casa Berardi gold resources in the open pit and underground block models are based on the density and quality of drill-hole data, the established continuity of the auriferous zones, and production experience. Only blocks within modeled mineral envelopes could be classified as Measured, Indicated or Inferred resources. The classification is applied using polygons that are modeled based on the proximity of block centroids relative to drill-hole composites and mine workings. The average distance of drill-hole composites used to estimate a given block grade was stored in the block models and used to model the polygons on screen. Underground rock-chip samples provided the location of mined mineralization. The polygons were drawn to approximate the 25m or 35m average distances for Measured or Indicated material, so the actual distances of the blocks are slightly above or below the applicable distance. The polygons were expanded or contracted by Hecla depending on the demonstrated continuity of the mineralization, which is a function of drilling density. The average distances chosen to assign Measured, Indicated and Inferred classification were chosen based on general drill-hole spacing, which ranges from 15m to 50m for many of the deposits. The Mineral Resources were classified as follows:

For underground resources:

- / Measured Mineral Resources: Blocks in modeled mineral envelopes within a mean distance of ~25m and underground development within close proximity that supports the continuity of mineralization.
- / Indicated Mineral Resources: Blocks in modeled mineral envelopes within a mean distance of ~25m that are not Measured Mineral Resources.
- / Inferred Mineral Resources: Blocks in modeled mineral envelopes outside a mean distance of ~25m. The mean distance of Inferred Mineral Resources is generally between 25m and 35m, and rarely up to 50m.

For open pit resources:

- / Measured Resources: Blocks in modeled mineral envelopes within a mean distance of ~35m and surface mining within close proximity that supports the continuity of mineralization.

149  
149

- / Indicated Resources: Blocks in modeled mineral envelopes within a mean distance of ~35m that are not Measured Mineral Resources.
- / Inferred Resources: Blocks in modeled mineral envelopes outside a mean distance of ~35m. The mean distance of Inferred Mineral Resources is generally 60m or less.

RESPEC has evaluated Hecla's classification for the Casa Berardi Mineral Resources, and concludes the following:

- / Hecla's application of mean distances used to estimate a given block grade is a reasonable approach to classifying resources. Average and closest distances (isotropic and anisotropic) of composites relative to blocks is commonly used in the mining industry for resource classification.
- / It is reasonable to upgrade resource classification from Inferred to Indicated for blocks in close proximity to mined mineralization.
- / Hecla's data compilation and verification process generally ensures that the assay and other drill data that form the basis for mineral envelope modeling and resource estimation are generally reliable. RESPEC also verified gold assays in Hecla's database against certificates for 2021 to 2023 and found only 20 errors in 85,903 assay records. The data verification justifies the classification of material as Indicated.
- / All or parts of drill-hole assays determined to be unreliable, due to QA/QC failures or unverifiable/conflicting assays in historical holes, are generally removed or replaced in the database. This adds confidence in the drill-hole database used for resource modeling and justifies classification of some material as Indicated.
- / Hecla's geologic and mineral envelope models reasonably guide and constrain gold estimation, which increases confidence that the overall reported Mineral Resources.
- / Relatively dense drilling defines mineralization in most of the underground and much of the open pit deposits. Density of drilling could be applied to classification by adding the number of holes and/or composites used to estimate a given block grade to classification criteria in conjunction with distances to composites.
- / The general production history and reasonable mined-versus-model reconciliation results validates past models and estimates and justifies the continued classification of material as Measured and Indicated.

## 11.11 CASA BERARDI MINERAL RESOURCES

The Casa Berardi deposits have been and will continue to be mined by open pit and underground methods. However, the underground reserves will be depleted within the next year, and mining from underground will cease. The Mineral Resources were tabulated to reflect current open pit/underground mining and mill extraction. To meet the requirement of reasonable prospects for eventual economic extraction for open pit resources, pit optimizations were run using the parameters summarized in Table 11-7. The effective date of these Mineral Resources is December 31, 2023, which is the date new as-built surveys were applied to constrain the reported resources.

150  
150

**Table STYLEREF 1 \s 11-. Open Pit Optimization Parameters by Pit**

	<b>F160 Mill</b>	<b>Principal Mill</b>	<b>WMCP Mill</b>	<b>F134 Mill</b>
Mining - Waste	\$3.46	\$3.46	\$3.46	\$3.46
Pit - Fixed Costs (Opex)	\$2.00	\$2.00	\$2.00	\$2.00
Milling (Opex)	\$22.13	\$22.13	\$22.13	\$22.13
G&A - Casa (Opex)	\$4.96	\$4.96	\$4.96	\$4.96
G&A - Val d'Or (Opex)	\$1.48	\$1.48	\$1.48	\$1.48
Maintenance (Opex)	\$1.14	\$1.14	\$1.14	\$1.14
Electrical (Opex)	\$0.77	\$0.77	\$0.77	\$0.77
Pit - Prep (Capex)	\$0.68	\$0.30	\$0.35	\$0.30
Mill (Capex)	\$-	\$-	\$-	\$-
G&A - Casa (Capex)	\$0.09	\$0.09	\$0.09	\$0.09
Reclamation (Capex)	\$1.01	\$1.01	\$1.01	\$1.01
Exploration (Capex)	\$0.22	\$0.22	\$0.22	\$0.22
Total	\$34.46	\$34.09	\$34.14	\$34.09
Refining - Au	\$2.97	\$2.97	\$2.97	\$2.97
Dilution	27%	20%	20%	20%
Mining Recovery	100%	93%	93%	93%
Mill Metallurgical Recovery	84.9%	63.2%	63.3%	63.2%
Reporting Cutoff Grade	0.97g/t Au	1.13g/t Au	1.13g/t Au	1.13g/t Au
Royalty	None	None	None	None

The reported open pit resources are fully block-diluted and constrained by an optimized pit shell. Resources were reported at the cutoff grades shown in Table 11-8, which range from 0.97g/t Au to 1.13g/t Au. The gold cutoff grade was calculated using the processing, general and administrative costs, gold price, recovery, and refining cost provided in Table 11-7. The mining cost is included in pit optimizations but is not included in the determination of the cutoff grade, as all material in a given pit would be removed as either ore or waste. The resource estimates are based on a combined open pit and underground mill feed of 4,400tpd.

Underground Mineral Resources are reported by tabulating all blocks within modeled mineral envelopes with estimated grades that exceed the calculated reporting cutoff grades, which vary for each zone or lens (sub-zone). Sterilized ground, including pillars and buffer zones below the bottom of pits, are excluded from Mineral Resources. The cutoff grades used by Hecla for reporting underground Mineral Resources as given in Table 11-9 range from 3.78g/t Au to 5.84g/t Au and are based on the following parameters:

- / Gold Price US\$1,750/oz Au
- / Mill Recovery Specific by Zone

151  
151

- / Operating Cost US\$183.08/t or US\$282.60/t
- / The cutoff grade is calculated by the following equations:
- / Revenue per unit gold:  $\text{US\$1,750/oz Au} \div 31.1035\text{g/oz Au} = \text{US\$56.26/g} \times \text{Mill recovery}$
- / Cutoff grade = Operating costs / Revenue per unit gold

**Table STYLEREF 1 \s 11-. Underground Mineral Resource Cutoff Grades by Zone**

Zone	Mill Recovery	Cutoff Grade	Operating Cost
	(%)	(g/t Au)	(US\$/t)
104, 107 to 109, 111, 113, 116, 117, 119, 124 and 129	86.20	3.78	183.08
115, 118, 121, 123 and 128	80.10	4.06	183.08
134, 139, 146, 152, 159 and 160	89.90	5.59	282.60
148	86.00	5.84	282.60

Mineral Resources were reported using US\$1,750/oz Au, which was chosen based on consensus, long-term forecasts from banks, financial institutions, and other sources, and a US\$/C\$ exchange rate of 1.300. The Casa Berardi Mineral Resources are presented in Table 11-9. The reported open pit resources are fully block diluted and are exclusive of Mineral Reserves. Underground Mineral Resources are undiluted and are also exclusive of Mineral Reserves. Mineral Resources that are not Mineral Reserves do not have demonstrated economic viability.

**Table STYLEREF 1 \s 11-. Underground and Open Pit Mineral Resources by Zone – December 31, 2023**

Classification and Zone	K Tonnes (t)	Grade (g/t Au)	Contained Metal (k oz Au)
Measured Mineral Resources			
Underground			
100 Lower Inter	120	8.63	33.3
101 North West	-	-	-
107	132	5.50	23.4
108	1	4.32	0.2
109	13	7.65	3.2
113	334	7.50	80.5
115	36	6.57	7.7
117	-	-	-
118	133	6.48	27.8

152  
152

Classification and Zone	K Tonnes (t)	Grade (g/t Au)	Contained Metal (k oz Au)
119	-	-	-
123	114	6.23	22.9
124	44	5.94	8.3
148	71	11.88	26.9
152	-	-	-
Total Underground	997	7.30	234.0
Open Pit			
WMCP	61	0.96	1.9
Principal	-	-	-
134	-	-	-
160	-	-	-
Total Open Pit	61	0.96	1.9
Total Measured Resources	1,058	6.94	235.9
Indicated Mineral Resources			
Underground			
100 Lower Inter	7	5.93	1.3
107	95	4.73	14.5
108	1	4.02	0.1
109	61	9.06	17.6
113	323	6.99	72.6
115	3	5.38	0.4
118	870	6.99	168.8
119	150	6.12	29.5
121	18	5.74	3.3
123	501	6.40	103.0
124	495	5.76	91.6
128	61	5.35	10.5
134	30	6.68	6.4
146	13	6.40	2.8
148	200	11.18	71.8

Classification and Zone	K Tonnes (t)	Grade (g/t Au)	Contained Metal (k oz Au)
159	21	7.15	4.9
160	14	7.34	3.4
Total Underground	2,861	6.55	602.5
Open Pit			
WMCP	27	0.96	0.8
Principal	54	0.98	1.7
134	1	0.96	0.0
160	104	0.69	2.3
Total Open Pit	186	0.81	4.9
Total Indicated Mineral Resources	3,048	6.20	607.4
Total Measured and Indicated	4,106	6.39	843.3
Inferred Mineral Resources			
Underground			
100 Lower Inter	5	14.15	2.2
104	85	5.70	15.6
107	0	4.02	0.0
108	6	4.65	0.8
113	89	6.98	20.0
116	214	13.28	91.5
118	182	6.23	36.4
119	55	5.65	10.0
121	8	5.22	1.4
123	233	6.43	48.2
124	150	6.14	29.6
129	56	7.03	12.7
134	25	7.13	5.7
139	96	7.80	23.9
146	15	6.11	2.9
148	55	9.44	16.8
152	12	7.78	2.9
157	3	6.67	0.6

154  
154

Classification and Zone	K Tonnes (t)	Grade (g/t Au)	Contained Metal (k oz Au)
159	17	6.55	3.6
160	33	6.47	6.8
Total Underground	1,338	7.71	331.6
Open Pit			
WMCP	51	1.81	3.0
Principal	522	2.96	49.6
134 (in reserve pit shell)	3	3.01	0.3
160 (in reserve pit design)	175	1.98	11.1
Total Open Pit	751	2.65	64.0
Total Inferred Mineral Resources	2,089	5.89	395.6

Notes:

1. In situ Mineral Resources are classified in accordance with the S-K 1300 classification system.
2. Mineral Resources were estimated by Hecla staff and reviewed and accepted by RESPEC.
3. Mineral Resources are exclusive of Mineral Reserves and do not have demonstrated economic viability.
4. Underground Mineral Resources are reported at cutoff grades ranging from 3.78g/t Au to 5.84g/t Au.
5. Open pit Mineral Resources are reported at cutoff grades ranging from 0.97g/t Au to 1.13g/t Au.
6. Underground and open pit Mineral Resources are reported using US\$1,750/oz Au, based on consensus, long term forecasts from banks, financial institutions, and other sources, and a US\$/C\$ exchange rate of 1.300.
7. A minimum mining width of three meters was used for the modeled open pit and underground mineral envelopes used to estimate Mineral Resources.
8. Totals may not represent the sum of the parts due to rounding.
9. Mineral Resources potentially amenable to open pit mining methods are reported using a gold price of US\$1,750/oz, a throughput rate of 4,400 tonnes/day (combined material from underground and open pit sources), surface mining costs of US\$3.46/tonne mined, milling processing costs of US\$24.13/tonne processed, and general and administrative and other costs ranged from \$9.96-10.34/tonne processed. Metallurgical recoveries were based on metallurgical curves.
10. Mineral Resources potentially amenable to underground mining methods are reported using a gold price of US\$1,750/oz and a throughput rate of 4,400 tonnes/day (combined material from underground and open pit sources). Operating costs are US\$183.08/ton mined or US\$282.60/ton mined, depending on the underground zone or lens. Mill recoveries also vary by zone or lens and range from 80.10% to 89.90%.

Table 11-9 A comparison of the December 31, 2023, and December 31, 2022 Mineral Resource estimates is given Appendix 4, and is summarized in Table 11-4. Gains and losses are a result of:

- / Geological reinterpretation of mineralized zones with new drilling.
- / Conversion of Mineral Resources into Mineral Reserves.
- / Mining depletion.
- / Subtraction of low-grade Mineral Resources (below cutoff grade).
- / Lower reporting cutoff grades in 2023.

155  
155

- / Changes in pit optimization parameters, e.g., mining costs, administrative costs, etc.
- / Change in reporting gold price from \$1,700/oz to \$1,750/oz.
- / Dilution applied to open pit optimizations was lowered in 2023.
- / Sterilization beneath the planned pits was applied to underground resources.
- / Open pit designs were used to constrain Mineral Resources in 2023 rather than optimizations, which were used in 2022.
- / Apparent gains and losses by upgrade of Inferred or Indicated Mineral Resources to Indicated or Measured Mineral Resources.

The 2022 Mineral Resources are superseded by the current 2023 Mineral Resources and are not relied upon by Hecla or RESPEC. RESPEC has not reviewed the 2022 Mineral Resource models or estimates.

## 11.12 DISCUSSION OF MINERAL RESOURCE ESTIMATES

The RESPEC QP reviewed Hecla's Casa Berardi open pit and underground models, both visually and statistically. Gold-grade smoothing during estimation is the primary issue in the models. Similar relationships were observed in all block models to varying degrees during on-screen cross-sectional reviews of estimated block grades versus down-hole composites. The structural zone wireframes confine the underground estimates more tightly compared to the open pit wireframes, such that the observed smoothing was less pronounced, particularly where drilling data is relatively dense. All Population distribution plots comparing bench composite grades to coincident estimated model grades show similar patterns. Estimated block grades are materially lower than their coincident bench composites in the high-grade portion of the plots, and the block grades in lower-grade material are significantly higher than the bench composites. The net result of this smoothing can be an overall overstatement of contained metal. Mine planning and production could be affected if fewer tonnes and higher grade than predicted by the model is encountered during mining.

Some grade smoothing is an unavoidable consequence of the modeling process from compositing to grade estimation in all resource models. At Casa Berardi, the smoothing can be significant, particularly in the open pit models. Constraint by the structural zone wireframes and 1.0g Au/t envelopes for the underground and open pit models, respectively, control the smoothing to some degree. The grade smoothing increases risk and diminishes confidence in the local distributions of gold grades and tonnes within the broader wireframes. The models likely overstate tonnes and understate grade, although the extent and the ultimate effects during mining cannot be fully quantified. It is recommended that the smoothing be minimized as much as possible.

The mined versus model reserve reconciliations provided by Hecla since 2020 were reviewed by RESPEC. In 2023, less tonnes at higher grade were mined from open pits; these results are expected in a smoothed grade model. The net result was more gold ounces produced. However, in 2020 through 2022, tonnes, grade and ounces mined by open pit were greater than predicted. If more tonnes of ore were found during mining that were missed by drilling, then the drill-spacing may not be sufficiently dense for the deposits. While producing more ounces than projected from the open pits is better than overpredicting, the reason more tonnes at higher grade are being encountered needs to be understood.

156  
156

The uncertainties associated with grade and tonne smoothing in the current models are offset in part by the bulk-tonnage mining scenario and generally positive open pit mined versus model reconciliations. Also, the history of productive mining at Casa Berardi using similar models and applied methodologies as those in the current models suggests that the performance of the current models will be similar. Finally, the remaining underground mine life is short (<1 year), which limits the effects of any potential issues associated with excessive smoothing.

RESPEC believes the models could be improved by further confining and separating relatively low- and high-grade mineralization within the 1.0g/t Au and 4.0g/t Au envelopes currently in use. An immediate improvement could be realized in the open pit models by using both sets of solids, such that the higher-grade mineralization within the structural zone wireframes would be separated from the lower-grade mineralization between the 1.0g/t Au and 4.0g/t Au envelopes.

The best method to minimize smoothing and more accurately represent grade distribution in a mineral estimate is to physically constrain the model with domains in proper geological context. Population distribution plots of all gold values provide a starting point for identification of the different assay populations that are likely characterized by specific lithologic, alteration and/or mineralogical characteristics. Modeling gold domains at grade breaks evident on plots of these types would limit grade smoothing to within related assay populations. Domain modeling while reviewing core and log data will help to determine the geological context of each grade population.

In lieu of changing the modeling approach, infill drilling in portions of the deposits with more widespread drill data would serve to better control grade smoothing.

The primary recommendations made by RESPEC are:

- / Apply tighter constraints to Mineral Resource estimates with additional geologically defined mineral envelopes.
- / Increase drilling density for open pit deposits where mineralization is missed and therefore cannot be modeled because the current spacing is insufficient.
- / Use the same block dimensions based on the SMU for all open pit block models.
- / Add mapping of pit faces and floors, and blasthole logs to Project database, and incorporate when updating geologic and mineral envelope models.

In conclusion, if mine vs model reconciliation and production results continue to be reasonable, then minimal changes are required. More gold ounces are generally being produced in the open pits than were predicted by the models. RESPEC believes that improvements to the model as suggested above would improve the predictive ability of the models, and in turn aid in mine planning and production. Overall, RESPEC believes that all issues relating to relevant technical and economic factors likely to influence the prospect of reasonable extraction can be resolved with further work, including the recommendations discussed above.

RESPEC is not aware of any environmental, permitting, legal, title, taxation, socio-economic, marketing, political, or other relevant technical and economic factors that would materially affect the Mineral Resource estimate.

## 12.0 MINERAL RESERVE ESTIMATES

Underground Mineral Reserves were estimated by Hecla Québec and reviewed by RESPEC. Estimates were prepared for the 118, 123, and 124 zones of the Principal Mine. A long-hole stoping mining method without pillars is assumed for all of the estimates. All stopes are backfilled after mining using paste fill, cemented rock fill (CRF), or unconsolidated waste rock.

Open Pit Mineral Reserves were estimated by RESPEC, for the WMCP, Principal, F134, and F160 pits.

Measured and Indicated Mineral Resources were converted to Proven and Probable Mineral Reserves, respectively. Inferred Mineral Resources were not converted to Mineral Reserves. Mineral Reserves as of December 31, 2023 are summarized in Table 12-1.

**Table STYLEREF 1 vs 12-. Summary of Mineral Reserves – December 31, 2023**

Reserve Category	K Tonnes (k t)	Grade (g/t Au)	Contained Metal (k oz Au)	Metallurgical Recovery (%)
Underground				
Proven	50	4.14	6.7	-
Probable	159	5.06	25.9	-
Proven + Probable	209	4.84	32.6	88.7
Open Pit				
Proven	3,846	3.07	379.4	-
Probable	10,327	2.59	858.5	-
Proven + Probable	14,174	2.72	1,237.9	81.3
Total				
Proven + Probable	14,383	2.75	1,270.5	81.5

Notes:

- Classification of Mineral Reserves is in accordance with the S-K 1300 classification system. Mineral Reserves are reported as in situ with the exception of mill stockpile volumes as defined in this report.
- RESPEC is responsible for the statement of Proven and Probable Mineral Reserves.
- Mineral Reserves are 100% attributable to Hecla.
- Underground Mineral Reserves are estimated at a cutoff grade of 3.60g/t Au for 124 Zone and a 3.88g/t Au for the 118 and 123 Zones.
- Open pit Mineral Reserves are estimated at a cutoff grade of 1.02g/t Au for the F160 pit and 1.18g/t Au for the WMCP, Principal, and F134 Pits.
- Underground Mineral Reserves are estimated using short-term gold price of US\$1,850/oz Au and open pit Mineral Reserves are estimated using a long-term gold price of US\$1,650/oz Au respectively and a US\$/C\$ exchange rate of 1.300.
- A minimum mining width of three meters was used for underground Mineral Reserves.

158  
158

RSI-M0206.22001

8. Totals may not represent the sum of the parts due to rounding.

Underground and open pit Mineral Reserves by zone are presented in Table 12-2.

**Table STYLEREF 1 \s 12-. Mineral Reserves by Zone – December 31, 2023**

<b>Zone</b>	<b>K Tonnes (k t)</b>	<b>Grade (g/t Au)</b>	<b>Contained Metal (k oz Au)</b>
Underground – Proven			
118	29	4.34	4.1
123	14	3.91	1.7
124	2	4.46	0.4
Stockpile	5	3.39	0.5
Total Underground – Proven	50	4.14	6.7
Underground – Probable			
118	122	5.42	21.2
123	37	3.91	4.7
124	-	0.00	-
Total Underground – Probable	159	5.06	25.9
<b>Total Underground Proven + Probable</b>	<b>209</b>	<b>4.84</b>	<b>32.6</b>
Open Pit – Proven			
WMCP	3,687	3.07	363.6
Principal	103	3.89	12.9
F134	-	0.00	-
F160	-	0.00	-
Stockpile	56	1.62	2.9
Total Open Pit – Proven	3,846	3.07	379.4
Open Pit – Probable			
WMCP	1,215	2.62	102.2
Principal	5,303	3.11	530.1
F134	90	3.61	10.4
F160	3,720	1.80	215.8
Total Open Pit – Probable	10,327	2.59	858.5
<b>Total Open Pit Proven + Probable</b>	<b>14,174</b>	<b>2.72</b>	<b>1,237.9</b>
Grand Total			

Proven	3,896	3.08	386.1
Probable	10,487	2.62	884.4
Proven + Probable	14,383	2.75	1,270.5

Notes:

1. Classification of Mineral Reserves is in accordance with the S-K 1300 classification system. Mineral Reserves are reported as in situ with the exception of mill stockpile volumes as defined in this report.
2. RESPEC is responsible for the statement of Proven and Probable Mineral Reserves.
3. Mineral Reserves are 100% attributable to Hecla.
4. Underground Mineral Reserves are estimated at a cutoff grade of 3.60g/t Au for 124 Zone and a 3.88g/t Au for the 118 and 123 Zones.
5. Open pit Mineral Reserves are estimated at a cutoff grade of 1.02g/t Au for the F160 pit and 1.18g/t Au for the WMCP, Principal, and F134 Pits.
6. Underground Mineral Reserves are estimated using short-term gold price of US\$1,850/oz Au and open pit Mineral Reserves are estimated using a long-term gold price of US\$1,650/oz Au respectively and a US\$/C\$ exchange rate of 1.300.
7. A minimum mining width of three meters was used for underground Mineral Reserves.
8. Totals may not represent the sum of the parts due to rounding.

RESPEC is not aware of any risk factors associated with, or changes to, any aspects of the modifying factors such as mining, metallurgical, infrastructure, permitting, or other relevant factors that could materially affect the Mineral Reserve estimate.

## 12.1 UNDERGROUND MINERAL RESERVES

Underground Mineral Reserves are reaching the end of their life and underground mining activities are planned to end in 2024.

Mineral Reserve estimates are based on the Mineral Resource 3D block models. Stope shapes are created based on individual zone and lens geometries. Stope designs, based on 15m spaced sections extrapolated along strike, are built to allow a preliminary economic assessment of the areas to be mined. The Mineral Resources within the stope shapes are exported to MS Excel and dilution and extraction factors are applied. Mining engineers then assess the economic prospects for each stope. Based on engineering considerations, lower grade blocks may be included in stope designs if their development is proposed in conjunction with other blocks. While the low grade block alone would not support the required development, it is considered economic if it can be developed with other blocks. Similarly, the evaluation of the extraction method or ground conditions may result in lower grade blocks being included in the Mineral Reserve estimate.

Underground zones containing Mineral Reserves are described below.

160  
160

Current production is situated between the 550m and 1,150m levels. From the 790m level, the 118 Zone's internal ramp system and mining levels are accessible. The 118\_06, 118\_11 and 41 lenses and mined by longitudinal stoping. Paste fill is available in the 118 Zone.

The 123 Zone lies approximately 250m to the south of the 118 Zone. The 123 Zone is accessed via an internal ramp system and mining levels from the 790m level. The 123 Zone consists of several sub-parallel lenses. Paste fill is also available in the 123 Zone below the 470m level. An internal ramp which connects the upper and lower levels of the 123 Zone. The 123-02, 05, 12, and 19 are the lenses still containing reserves.

The 124 Zone is in the upper portion of the West Mine, and consists of several sub-parallel lenses, which are currently mined from the underground, below the 150m level. The upper portion of the 124 Zone, extending from surface to the 185m level, is planned for open pit mining. Paste fill is not available in the Principal Pit area of the West Mine. Stopes are backfilled with CRF and uncemented rock fill in this area. The 124-81 lens contains the reserve material.

## 12.2 OPEN PIT MINERAL RESERVES

With the completion of XMCP in 2023 the remaining open pits include F160, WMCP, Principal and F134.

### 12.2.1 F160 PIT

The F160 Pit is located northeast of the mill. The 159 and 160 lens (both included in the F160 Pit) are currently the most easterly identified lens on the Property. Currently, Phase 2 is being mined and overburden removal is expected to continue until Q4 2024. The final phase of the F160 Pit will be completely mined in 2026. The average planned ore tonnage is 3,395tpd. The F160 Pit will not intersect any underground workings.

### 12.2.2 WMCP PIT

The WMCP Pit is the most westerly pit in the Casa Berardi Mineral Reserves. Prior to commencing this project, surface infrastructure (e.g., a cement plant and access roads) will have to be redesigned and/or relocated and environmental considerations will have to be addressed. The WMCP Pit will intersect multiple underground excavations. The development of the WMCP Pit is planned to coincide with the end of underground mining in the West Mine area as it will affect West Mine infrastructure. Overburden removal is planned to commence in 2031 and will take three years. The WMCP Pit Mineral Reserve will be mined between 2032 and 2037, at a rate of 2,681tpd.

### 12.2.3 PRINCIPAL PIT

Overburden removal in the Principal Pit area is planned to begin in 2028 whereas ore mining is planned to begin in 2030 at a peak rate of 4,752tpd in 2031. Environmental and engineering challenges regarding pumping are being addressed and are still in progress. The Principal Pit will intercept underground workings (in the lower part of the pit).

161  
161

#### 12.2.4 F134 PIT

The F134 Pit is located to the southeast of the Principal Pit. The 134 Pit will not intersect any underground workings and is independent of the Principal Pit. A dewatering program will be required to control water inflow from runoff and from the rock mass. Mining will begin in 2037 and be complete the same year. The overburden and waste rock will be used to backfill the Principal Pit.

### 12.3 CUTOFF GRADE

The cutoff grade used for reporting Mineral Reserves is based on the following parameters:

- / Gold price: US\$1,850/oz Au for Underground and US\$1,650/oz Au for Open Pit.
- / Exchange rate of C\$1.30/US\$1.00.
- / Metallurgical recovery by zone as presented in Table 12-3.
- / The underground and open pit cutoff grades are presented in Table 12-3.

**Table STYLEREF 1 \s 12-. Underground and Open Pit Reserve Cutoff Grades**

Zone	Metallurgical Recovery	Cutoff Grade Mill Recovery	Cutoff Grade	
	(%)	(%)	(g/t Au)	
Underground Zones				
118	81.1	-	4.28	
119	86.8	-	4.00	
123	81.1	-	4.28	
124	86.8	-	4.00	
Open Pits				
Principal	83.0	64.5	1.18	
134	84.5	64.5	1.18	
160	88.7	85.3	1.02	
WMCP	75.9	64.3	1.18	

When the grade of the Mineral Reserves is close to the cutoff grade, a more detailed review is completed considering the anticipated costs and revenues.

Individual stopes were evaluated using the cutoff grade for the applicable zone, after dilution and extraction factors had been applied.

Hecla has reviewed the market demands and projections for gold prices. They also provided long-term (ten-year) metal price forecasts. Gold is a viable product that is readily sold to open markets without any limitations. RESPEC has reviewed the gold pricing information with respect to the selected gold price for use in this feasibility and agrees with its use for estimating Mineral Reserves.

162  
162

## 12.4 DILUTION AND EXTRACTION

### 12.4.1 UNDERGROUND MINING

For underground mining, internal dilution is defined as material below the cutoff grade included within a mining block. Internal dilution represents areas included within the Mineral Resource envelopes for continuity and areas outside of the Mineral Resource envelope required to optimize the mining geometry. Internal dilution is intended to be mined with the ore and is included in the Mineral Reserve estimate of a stope.

External dilution is defined as unplanned and uneconomic material coming from the periphery of a mining block. It includes material from the hanging wall or footwall and from exposure of backfill in adjacent stopes. The estimation of underground external dilution is based on the 17 years of underground operating experience at the mine and is expressed as a percentage, calculated as:

Dilution % = (waste tonnes / ore tonnes) x 100.

The average total dilution from internal and external sources for the underground Mineral Reserves is 35% (Table 12-4).

Extraction is the proportion of the diluted Mineral Reserve which is expected to be extracted by mining. The extraction by zone is presented in Table 12-4.

Average extraction is estimated to be 94.5%. Timely placement of backfill and other measures to control stope deterioration are key to achieving high extraction rates in this pillarless mining scenario.

Dilution has been estimated on a stope-by-stope basis considering the planned mining and conditions in the given areas. The dilution estimates reflect the expected conditions in the mature mining areas.

A review of drill hole and block model grades immediately outside stope outlines indicates that mineral boundaries are generally gradational, ranging from 0.5g/t Au to 1.0g/t Au at stope boundaries, instead of being sharply cut. A grade of 0.5g/t Au has been applied to hanging wall/footwall dilution in all zones.

Table STYLERE 1 \s 12-. Dilution and Extractions Estimates – Underground

Zone	Dilution		Extraction	
	Longitudinal	Transverse	Longitudinal	Transverse
118	33.5%	26.6%	94.7%	91.7%
123	23.1%	22.2%	94.7%	91.7%
124	26.4%	19.2%	94.7%	91.7%

## 12.4.2 OPEN PIT MINING

For open pit mining, internal dilution is defined as material below the cutoff grade within the Mineral Resource envelope. Internal dilution can also be partially estimated by comparing the envelope geometry to bench geometry, as benches are square vertical blocks and the mineral zones dip at angles of between 45° and 70°.

External dilution in open pit mining is defined as material below the cutoff grade that is mixed with ore during the blasting process or picked up by the excavators at the contact between the mineralized package and the waste matrix.

The F160 Pit has been operating since 2020. The dilution estimates for the F160 Pit are based upon this recent mining experience. For subsequent pits, dilution estimates will reflect calculated ore loss and dilution.

Extraction by zone is presented in Table 12-5.

For open pit mining, a 100% extraction factor is used for F160 while a factor of 93% is used for the future pits which are planned to be mined on larger benches. These factors are supported by reconciliation numbers.

**Table 12-5. Dilution and Extractions Estimates – Open Pit**

Pit	Dilution (%)	Extraction (%)
WMCP	20	93
Principal	20	93
F134	20	93
F160	27	100

## 12.5 ESTIMATION METHODOLOGY – OPEN PIT PROJECTS

For each of the open pit projects described in the following subsections, optimized pit shells based on the block models prepared by Hecla Québec's geology department were used. Surpac scripts were used to code materials and surfaces within the block model (i.e., overburden material types and bedrock contact). The pit shells were generated using Whittle. Implicit average diluted cutoff grades ranging from 0.90g/t Au to 1.07g/t Au were used. Slope angles and other design criteria are discussed in Section 13.0 of this TRS. The open pit cutoff grade mill recoveries below are solely used to calculate the cutoff. They represent the estimated metallurgical recoveries in the vicinity of the open pit gold cutoff grades and are significantly lower than the metallurgical recoveries related to the average mill fee gold grades.

### 12.5.1 F160 PIT

Hecla estimated the F160 Pit Mineral Reserves, using updated economic parameters and an updated block model developed by the Hecla Québec mine geology department. A pit optimization and design were completed by Hecla.

Mineral Reserves were estimated for this pit design based on an implicit diluted cutoff grade of 1.02g/t Au, and the following inputs:

- / Operating costs of US\$34.46/t ore.
- / Cutoff grade mill recovery of 85.3%.
- / Gold price of US\$1,650/oz Au.
- / Dilution of 27%.

#### 12.5.2 WMCP PIT

In Q4 2021, Hecla estimated the WMCP Pit Mineral Reserves, using updated economic parameters and an updated block model developed by the Hecla Québec mine geology department. A pit optimization and design were completed by Hecla.

Mineral Reserves were estimated for the WMCP Pit shell based on an implicit diluted cutoff grade of 1.18g/t Au, and the following inputs:

- / Operating costs of US\$34.14/t ore.
- / Cutoff grade mill recovery of 64.3%.
- / Gold price of US\$1,650/oz Au.
- / Dilution of 20%.

#### 12.5.3 PRINCIPAL PIT

The Principal Pit Mineral Reserves were calculated using updated economic parameters, based on a block model developed by Hecla Québec (geology) department. A pit optimization and design were completed by Hecla.

Mineral Reserves were estimated for this pit shell based on an implicit average diluted cutoff grade of 1.18 g/t Au, and the following inputs:

- / Operating costs of US\$34.09/t ore.
- / Cutoff grade mill recovery of 64.5%.
- / Gold price of US\$1,650/oz Au.
- / Dilution of 20%.

#### 12.5.4 F134 PIT

In Q4 2021, Hecla updated the F134 Pit Mineral Reserves, using updated economic parameters, and an updated block model developed by the Hecla Québec mine geology department. A pit optimization was completed by Hecla with RESPEC completing the design.

Mineral Reserves were estimated for this pit shell based on an implicit diluted cutoff grade of 1.18g/t Au, and the following inputs:

- / Operating costs of US\$34.09/t ore.
- / Cutoff grade mill recovery of 64.5%.
- / Gold price of US\$1,650/oz Au.

/ Dilution of 20%.

## 12.6 COMPARISON TO PREVIOUS ESTIMATES

The December 31, 2023 Mineral Reserve estimate represents an overall decrease of 2.23M tonnes and 331k oz Au as compared to the December 31, 2022 Mineral Reserve estimate.

A summary of gains and losses is presented in Table 12-6.

From 2021 to 2023, Mineral Reserves underground decreased due to ongoing mining in all zones, as well as a write down in the East Mine due to ongoing challenging conditions. Over the same period, Mineral Reserves decreased in all open pits due to mining activity.

**Table STYLEREF 1 vs 12-. Change in Mineral Reserves 2023 to 2022**

Zone	December 31, 2023			December 31, 2022			Change	
	K Tonnes	Grade (g/t Au)	Contained Metal (K toz Au)	K Tonnes	Grade (g/t Au)	Contained Metal (K oz Au)	K Tonnes	Contained Metal (K toz Au)
<b>Proven</b>								
Lower Inter	-	-	-	6	9.58	2.0	(6)	(2.0)
113	-	-	-	37	5.24	6.3	(37)	(6.3)
118	29	4.34	4.1	117	5.56	21.0	(88)	(17)
123	14	3.91	1.7	145	5.52	25.7	(131)	(24)
124	2	4.46	0.4	23	5.64	4.2	(21)	(3.9)
East Mine U/G (148)	-	-	-	106	6.86	23.5	(106)	(23.5)
WMCP Pit	3,687	3.07	363.6	3,832	3.26	401.0	(145)	(37.4)
EMCP + Ext. Pit	-	-	-	5	2.78	0.4	(5)	(0.4)
Principal Pit	103	3.89	12.9	117	3.84	14.5	(15)	(1.6)
F134 Pit	-	-	-	-	-	-	-	-
F160 Pit	-	-	-	46	0.92	1.4	(46)	(1.4)
<b>Total Proven Mineral Reserves</b>	<b>3,896</b>	<b>3.08</b>	<b>386.1</b>	<b>4,436</b>	<b>3.51</b>	<b>499.9</b>	<b>(539)</b>	<b>(113.8)</b>
<b>Probable</b>								
Lower Inter	-	-	-	3	7.34	0.8	(3)	(0.8)
113	-	-	-	169	6.42	34.9	(169)	(34.9)
118	122	5.42	21.2	227	5.48	40.0	(105)	(18.8)
119	-	-	-	15	4.96	2.3	(15)	(2.3)

166  
166

Zone	December 31, 2023			December 31, 2022			Change	
	K Tonnes	Grade (g/t Au)	Contained Metal (K toz Au)	K Tonnes	Grade (g/t Au)	Contained Metal (K oz Au)	K Tonnes	Contained Metal (K toz Au)
123	37	3.91	4.7	235	5.48	41.3	(197)	(36.7)
124	-	-	-	120	5.31	20.5	(120)	(20.5)
East Mine U/G (148)	-	-	-	116	6.52	24.2	(116)	(24.2)
WMCP Pit	1,215	2.62	102.2	1,219	2.73	107.1	(4)	(4.9)
Principal Pit	5,303	3.11	530.1	5,446	3.12	546.6	(144)	(16.5)
F134 Pit	90	3.61	10.4	109	3.42	11.9	(19)	(1.5)
F160 Pit	3,720	1.80	215.8	4,322	1.87	259.2	(602)	(43.4)
<b>Total Probable Mineral Reserves</b>	<b>10,487</b>	<b>2.62</b>	<b>884.4</b>	<b>12,177</b>	<b>2.81</b>	<b>1,101.6</b>	<b>(1,690)</b>	<b>(217.2)</b>
<b>Proven and Probable</b>								
<b>Total Proven and Probable Mineral Reserves</b>	<b>14,383</b>	<b>2.75</b>	<b>1,270.5</b>	<b>16,613</b>	<b>3.00</b>	<b>1,601.5</b>	<b>(2,230)</b>	<b>(331.0)</b>

Notes:

1. The 2022 Mineral Reserves are superseded by the current 2023 Mineral Reserves and are not relied upon by Hecla or RESPEC. RESPEC has not reviewed the 2022 Mineral Reserve models or estimates.
2. The 2023 classification of Mineral Reserves is in accordance with the S-K 1300 classification system. Mineral Reserves are reported as in situ with the exception of mill stockpile volumes as defined in this report.
3. RESPEC is responsible for the statement of Proven and Probable Mineral Reserves for 2023.
4. Mineral Reserves are 100% attributable to Hecla.
5. The 2023, underground Mineral Reserves are estimated at a cutoff grade of 3.60g/t Au for 124 Zone and a 3.88g/t Au for the 118 and 123 Zones.
6. The 2023, open pit Mineral Reserves are estimated at a cutoff grade of 1.02g/t Au for the F160 pit and 1.18g/t Au for the WMCP, Principal, and F134 Pits.
7. The 2023, underground Mineral Reserves are estimated using short-term gold price of US\$1,850/oz Au and open pit Mineral Reserves are estimated using a long-term gold price US\$1,650/oz Au respectively and a US\$/C\$ exchange rate of 1.300.
8. A minimum mining width of three meters was used for the 2023 underground Mineral Reserves.
9. Totals may not represent the sum of the parts due to rounding.

## 12.7 RECONCILIATION

Tonnage and grade reconciliations between Mineral Reserves, mine plans, and mill production are carried out by Hecla on an individual stope by stope basis and reported on a monthly and annual basis. The annual results for 2006 to 2023, and the comparisons between the mill production and Mineral Reserves and mill production and planned mining are presented in Table 12-7 and Table 12-8. The same information on a monthly basis for 2023 is shown in Table 12-9 and Table 12-10.

Tonnes, gold grades, and gold ounces for the block model estimates and the final design plans are compared to mill production.

On an annual basis, the reconciliation between the mill production, Mineral Reserves, and mine plans with respect to tonnage, grade, and contained gold is very consistent, with 79 of the 162 data points within  $\pm 5\%$ .

**Table 12-7. Mine-Mill Reconciliation – 2006 to 2023**

Year	Mineral Reserve			Planned Reserve			Mill		
	Tonnage kt	Grade g/t Au	Contained Ounces koz	Tonnage kt	Grade g/t Au	Contained Ounces koz	Tonnage kt	Grade g/t Au	Contained Ounces koz
2023 PIT	936.7	1.65	49.7	930.8	1.75	52.4	936.0	1.72	51.8
2023 UG	370.4	4.92	58.6	232.9	4.75	35.6	224.9	4.57	33.1
2022 PIT	799.3	1.70	43.7	827.5	1.82	48.3	841.4	1.81	48.9
2022 UG	551.5	4.98	88.2	433.2	5.24	72.9	444.9	5.29	75.6
2021 PIT	638.5	1.76	36.2	748.3	1.93	46.3	743.7	1.93	46.2
2021 UG	643.8	4.95	102.6	405.3	5.28	68.7	424.7	5.56	75.9
2020 PIT	502.1	2.08	33.5	505.2	2.22	36.1	520.1	2.07	34.7
2020 UG	713.2	5.26	120.6	285.6	6.99	64.2	284.0	7.44	67.9
2019 PIT	505.7	1.90	30.8	506.3	1.96	31.9	523.7	1.88	31.6
2019 UG	695.9	5.67	126.9	388.5	6.37	79.6	427.7	6.34	87.1
2018 PIT	498.1	2.22	35.5	521.6	2.02	33.9	570.4	1.99	36.5
2018 UG	715.9	6.68	153.7	521.4	6.56	110.0	531.8	7.13	121.9
2017 PIT	365.9	2.81	33.0	463.8	2.80	41.8	468.2	2.93	44.0
2017 UG	626.8	6.45	130.0	478.3	6.24	95.9	506.2	6.20	101.0
2016 PIT	94.5	2.50	7.6	132.8	2.61	11.1	132.7	2.26	9.7
2016 UG	676.0	5.98	130.0	509.9	6.31	103.4	564.5	6.64	120.6
2015 U/G	701.6	6.04	136.1	736.7	5.87	139.1	765.8	5.96	146.7
2014 U/G	653.9	6.59	138.6	725.2	5.93	138.2	750.8	5.90	142.4
2013 U/G	571.2	6.26	115.0	583.0	5.80	108.7	590.6	6.16	117.0
2012 U/G	632.2	7.75	157.5	685.5	6.72	148.2	693.9	6.77	151.1
2011 U/G	735.1	7.96	188.2	726.9	7.50	175.3	698.1	8.00	179.5
2010 U/G	683.4	6.83	150.0	670.4	6.69	144.2	722.7	6.76	157.1
2009 U/G	719.6	7.51	173.7	684.6	7.06	155.4	688.7	7.77	172.0
2008 U/G	662.1	8.54	181.7	706.7	8.06	183.0	654.4	8.16	171.6
2007 U/G	548.1	10.41	183.4	579.5	10.21	190.2	545.3	9.78	171.4
2006 U/G	64.0	9.18	18.9	66.6	8.89	19.0	68.5	8.58	18.9
<b>Total</b>	<b>15,305.8</b>	<b>5.33</b>	<b>2,624.0</b>	<b>14,056.5</b>	<b>5.16</b>	<b>2,333.4</b>	<b>14,323.7</b>	<b>5.24</b>	<b>2,414.2</b>

Table STYLEREF 1 \s 12-. Mine-Mill Reconciliation – 2006 to 2023

Year	Mill versus Planned Reserve			Mill versus Mineral Reserve		
	(%)			(%)		
	Tonnes	Grade	Ounces	Tonnes	Grade	Ounces
2023 PIT	101%	98%	99%	100%	104%	104%
2023 UG	97%	96%	93%	61%	93%	56%
2022 PIT	102%	100%	101%	105%	106%	112%
2022 UG	103%	101%	104%	81%	106%	86%
2021 PIT	99%	100%	100%	116%	110%	128%
2021 UG	105%	105%	110%	66%	112%	74%
2020 PIT	103%	93%	96%	104%	100%	104%
2020 UG	99%	106%	106%	40%	141%	56%
2019 PIT	103%	96%	99%	104%	99%	102%
2019 UG	110%	100%	110%	61%	112%	69%
2018 PIT	109%	98%	107%	115%	90%	103%
2018 UG	102%	109%	111%	74%	107%	79%
2017 PIT	101%	104%	105%	128%	104%	133%
2017 UG	106%	99%	105%	81%	96%	78%
2016 PIT	100%	87%	87%	140%	90%	127%
2016 UG	111%	105%	117%	84%	111%	93%
2015 U/G	104%	102%	106%	109%	99%	108%
2014 U/G	104%	100%	103%	115%	90%	103%
2013 U/G	101%	106%	108%	103%	98%	102%
2012 U/G	101%	101%	102%	110%	87%	96%
2011 U/G	96%	107%	102%	95%	100%	95%
2010 U/G	108%	101%	109%	106%	99%	105%
2009 U/G	101%	110%	111%	96%	103%	99%
2008 U/G	93%	101%	94%	99%	96%	94%
2007 U/G	94%	96%	90%	99%	94%	93%
2006 U/G	103%	96%	99%	107%	94%	100%
Total	102%	102%	103%	94%	98%	92%

Table STYLEREF 1 \s 12-. Mine-Mill Reconciliation – 2023

Month	Mineral Reserves			Planned Reserves			Mill		
	K Tonnes	Grade (g/t Au)	Contained Metal K oz Au	K Tonnes	Grade (g/t Au)	Contained Metal K oz Au	K Tonnes	Grade (g/t Au)	Contained Metal K oz Au
JANUARY UG	31.4	4.36	4.4	27.2	4.49	3.9	26.7	4.25	3.6
JANUARY PIT	118.9	1.23	4.7	97.8	1.61	5.1	94.2	1.65	5.0
FEBRUARY UG	20.6	4.52	3.0	20.3	4.13	2.7	19.9	4.49	2.9
FEBRUARY PIT	86.5	1.63	4.5	95.1	1.56	4.8	90.1	1.52	4.4
MARCH UG	30.4	6.15	6.0	34.6	4.59	5.1	32.5	4.35	4.5
MARCH PIT	63.9	1.08	2.2	68.6	1.49	3.3	68.5	1.45	3.2
APRIL UG	24.2	4.99	3.9	27.1	4.95	4.3	27.3	4.75	4.2
APRIL PIT	107.1	1.35	4.7	104.3	1.41	4.7	99.8	1.38	4.4
MAY UG	18.4	6.02	3.6	27.6	4.82	4.3	27.0	3.96	3.4
MAY PIT	110.3	1.42	5.0	96.8	1.74	5.4	100.2	1.63	5.3
JUNE UG	14.2	5.93	2.7	16.0	5.45	2.8	14.6	5.73	2.7
JUNE PIT	32.9	1.47	1.6	26.8	1.67	1.4	26.9	1.60	1.4
JULY UG	35.4	4.93	5.6	32.9	5.17	5.5	34.8	4.81	5.4
JULY PIT	77.4	1.73	4.3	74.4	1.79	4.3	80.4	1.92	5.0
AUGUST UG	21.1	5.21	3.5	22.3	4.52	3.2	22.1	4.45	3.2
AUGUST PIT	65.8	2.74	5.8	63.6	2.84	5.8	69.5	2.39	5.3
SEPTEMBER UG	23.6	6.25	4.7	25.9	5.02	4.2	26.4	4.67	4.0
SEPTEMBER PIT	35.3	1.41	1.6	50.7	1.41	2.3	50.1	1.34	2.2
OCTOBER UG	16.9	3.85	2.1	20.8	3.70	2.5	18.3	4.12	2.4
OCTOBER PIT	112.7	2.02	7.3	108.3	1.96	6.8	106.7	2.13	7.3
NOVEMBER UG	63.5	2.12	4.3	66.9	1.83	3.9	70.5	1.74	4.0
NOVEMBER PIT	29.3	5.04	4.7	28.8	4.72	4.4	27.6	5.06	4.5
DECEMBER UG	62.6	1.85	3.7	77.6	1.83	4.6	79.1	1.73	4.4
DECEMBER PIT	28.7	4.29	4.0	25.7	3.79	3.1	23.9	3.51	2.7
<b>Total</b>	<b>1,230.9</b>	<b>2.48</b>	<b>98.0</b>	<b>1,240.0</b>	<b>2.47</b>	<b>98.4</b>	<b>1,237.1</b>	<b>2.39</b>	<b>95.2</b>

170  
170

Table STYLEREF 1 \s 12-. Mine-Mill Reconciliation – 2023

Month	Mill vs. Planned Reserve			Mill vs. Mineral Reserve		
	Tonnes	Grade	Contained	Tonnes	Grade	Contained
JANUARY UG	98%	95%	93%	85%	98%	83%
JANUARY PIT	96%	103%	99%	79%	135%	107%
FEBRUARY UG	98%	109%	107%	97%	99%	96%
FEBRUARY PIT	95%	97%	92%	104%	93%	97%
MARCH UG	94%	95%	89%	107%	71%	76%
MARCH PIT	100%	97%	97%	107%	134%	144%
APRIL UG	101%	96%	97%	113%	95%	107%
APRIL PIT	96%	98%	93%	93%	102%	95%
MAY UG	98%	82%	81%	147%	66%	97%
MAY PIT	104%	94%	97%	91%	115%	104%
JUNE UG	91%	105%	96%	103%	97%	99%
JUNE PIT	100%	96%	96%	82%	109%	89%
JULY UG	106%	93%	98%	98%	97%	96%
JULY PIT	108%	107%	116%	104%	111%	116%
AUGUST UG	99%	98%	98%	105%	85%	89%
AUGUST PIT	109%	84%	92%	106%	87%	92%
SEPTEMBER UG	102%	93%	95%	112%	75%	84%
SEPTEMBER PIT	99%	95%	94%	142%	95%	135%
OCTOBER UG	88%	111%	98%	108%	107%	116%
OCTOBER PIT	98%	108%	107%	95%	106%	100%
NOVEMBER UG	96%	107%	102%	94%	100%	95%
NOVEMBER PIT	105%	95%	100%	111%	82%	92%
DECEMBER UG	93%	93%	87%	83%	82%	68%
DECEMBER PIT	102%	95%	96%	126%	93%	118%
<b>Total</b>	<b>100%</b>	<b>97%</b>	<b>97%</b>	<b>101%</b>	<b>97%</b>	<b>97%</b>

The annual and monthly reconciliation charts for tonnage, grade, and contained ounces are provided in Figure 12-1 to Figure 12-3, respectively. The monthly variance between the mill production, Mineral Reserves, and mine plan has a larger range than the annual average, as demonstrated in Table 10-2 and in Figure 12-1 to Figure 12-3.

RESPEC is of the opinion that there is good reconciliation between the Mineral Reserves, mine planning, and the actual production. The annual and monthly reconciliation reports allow the reconciliation over time on a stope-by-stope basis and/or on a zone by zone basis to be examined. Based upon the reconciliation results, Hecla is of the opinion that the Mineral Reserve estimation and mine planning are reliable.

171  
171

Figure STYLEREF 1 \s 12-. Tonnage Reconciliation 2016 to 2023 Annual

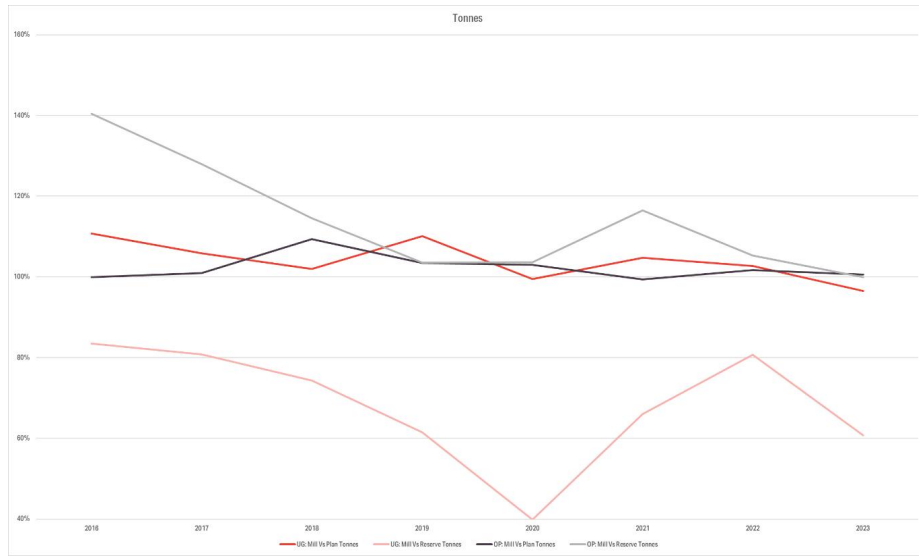
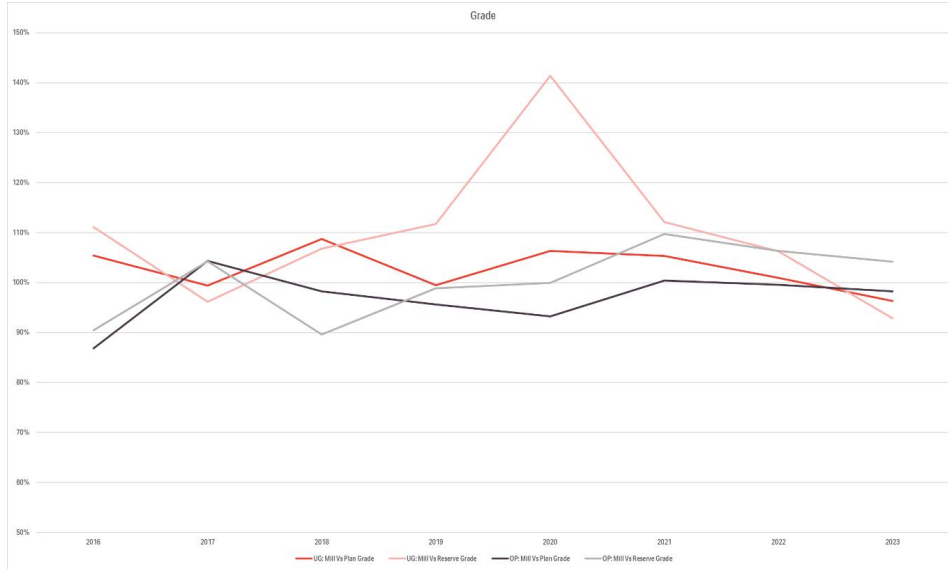
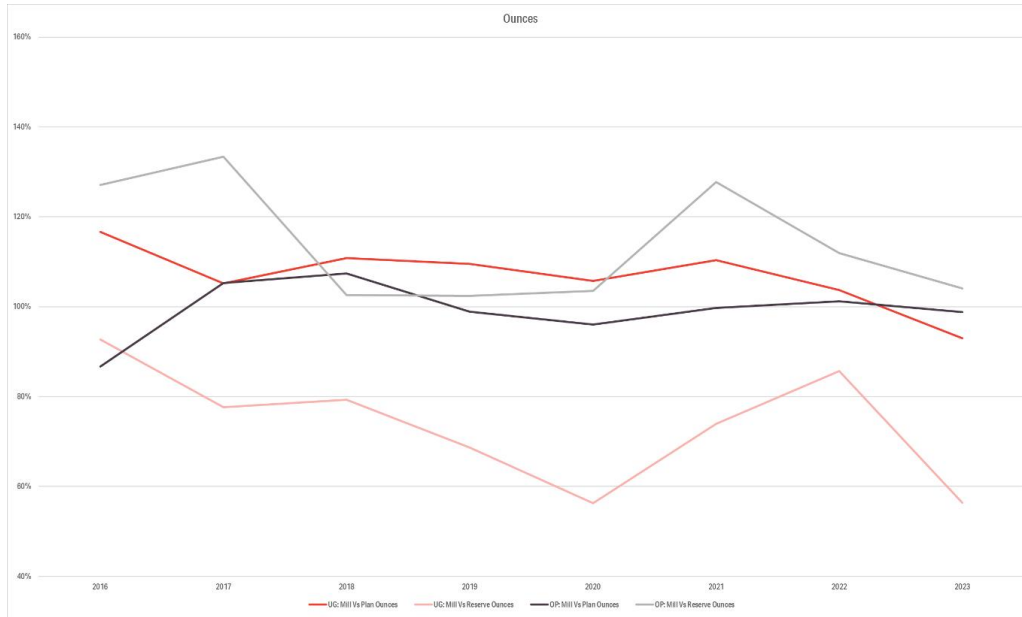

Figure STYLEREF 1 \s 12-. Grade Reconciliation 2016 to 2023 Annual



172  
172

Figure STYLEREF 1 \s 12-. Contained Gold Reconciliation 2016 to 2023 Annual



In the opinion of RESPEC, Casa Berardi Mineral Reserves have been estimated using industry best practices, and in accordance with the S-K 1300 classification system. RESPEC is not aware of any risk factors associated with, or changes to, any aspects of the modifying factors such as mining, metallurgical, infrastructure, permitting, or other relevant factors that could materially affect the Mineral Reserve estimate.

## 13.0 MINING METHODS

### 13.1 MINING OPERATIONS – UNDERGROUND

Inco Gold operated the East Mine from 1988 to 1991. From 1991 to 1997, TVX operated the East and West underground mines. In 2006, Aurizon, now known as Hecla Québec, restarted underground operations at the West Mine, and in late 2017 Hecla began the rehabilitation of the East Mine.

Initially, both mines were developed as trackless operations, with all material transported to surface via ramps. In 1995, a track drift and the East Shaft were completed to connect the East and West Mines.

In 2006, the 5.5m diameter West Shaft was sunk to the 795m level, and ramp and level development were completed to access mining zones. In 2013, the West Shaft was deepened to the 1,080m level.

As of December 2023, the majority of future underground mining will come from the 118, 123, and 124 zones, which will account for 78%, 21%, and 1% of underground production, respectively. These zones represent the bulk of the underground Mineral Reserves.

#### 13.1.1 UNDERGROUND DEVELOPMENT

Development openings have been sized to meet safety and regulation standards, accommodate mining equipment fleet, and meet the ventilation network requirements.

/ Ramp dimensions: 4.5m wide x 4.5m high.

/ Haulage drift dimensions: 4.5m wide x 4.5m high.

##### 13.1.1.1 GROUND SUPPORT

Ground control measures are applied systematically to ensure safe workplaces, limit dilution and overbreak, and stabilize weak rock masses, particularly in the vicinity of the main fault zones.

The following ground control measures are applied:

/ Cable bolting or connectable inflatable friction bolts are used in intersections and large spans to provide long-term ground stability.

/ Intersections are limited to three-way intersections and the creation of four-way intersections is avoided.

/ Development parallel to major structures or faults (i.e., silling out along the fault) is minimized by developing perpendicular to major structures wherever possible.

/ Test holes are used to confirm the position and width of the Casa Berardi Fault. Based on these test holes zones requiring the installation of spiling and shortened development round support with fiber-reinforced shotcrete are identified. This support is applied an additional two meters before and beyond the Casa Berardi Fault.

/ Test holes, shotcrete, spiling, and other specialized ground support requirements are integrated in the weekly mine planning to ensure that potentially unstable conditions are supported in a rapid and timely manner.

Casa Berardi mine personnel identify potentially unstable joints and abnormal conditions as they are exposed. These situations are evaluated on an individual basis and where required the ground support is modified to stabilize the

174  
174

---

potential instability. Information regarding ground conditions is communicated daily through the ground control logbook.

### 13.1.1.2 DEVELOPMENT PERFORMANCE

Mine development for much of the remainder of the mine life has been completed, and remaining development will be mined as necessary to facilitate the mine plan through the end of the mine life in 2024.

### 13.1.1.3 MINE DESIGN

The mine design and planning processes reflect the past mining experience at the West and East Mines. The following design criteria are used by Hecla Québec:

- / 2024 cutoff grade varies by zone from 3.60g/t Au to 3.88g/t Au.
- / Production rate: target approximately 1,140tpd of ore.
- / Production and development crews work two ten-hour shifts, seven days per week, 365 days per year. The crew rotation is seven days on, seven days off.
- / The mill operates two 12-hour shifts, seven days per week, 365 days per year.
- / Crews work 7 days in and 7 days off on rotation.
- / Ramp and shaft access to the mining areas.
- / Ramp dimensions: 4.5m wide x 4.5m high.
- / Sublevel spacing: 20m.
- / Typical stope dimensions: 20m high, 15m strike-length, up to 20m wide
- / Minimum mining width of three meters.
- / Haulage drift dimensions: 4.5m wide x 4.5m high.
- / 2.7m diameter ore and waste passes.
- / 2.4m and 3.3m diameter ventilation raises.

### 13.1.2 WEST MINE AND PRINCIPAL AREA

The current Mineral Reserves at Casa Berardi comprise three zones in the West Mine including the Principal area. These zones are spread out over a distance of 200m perpendicular to strike, 1,500m to 2,000m along strike and from surface to 1,090m below surface. The 118, 123 and 124 zones comprise the Mineral Reserve tonnage.

The zones vary in thickness, ranging from over 50m to less than three meters (e.g., minimum mining width). In general, the zones are subvertical (e.g., 55° to 85°).

A combination of longitudinal and transverse blasthole stoping is used at Casa Berardi, depending on mineral zone geometry (width and attitude) and development requirements. While timely delivery of backfill plays a crucial role in controlling dilution and maintaining the short stoping cycle.

175  
175

### 13.1.3 TRANSVERSE METHOD

The transverse mining method is used in areas with wide mineralization, 10m wide or more, and good access from nearby development such as haulage drift and multiple draw points. In wide areas, greater than 20m, stopes are subdivided into smaller panels and mined in sequence from the hanging wall to the footwall.

Stopes are nominally 15m long by 20m high, sill to sill, oriented in a transverse manner to the strike of the ore, and are mined using a primary and secondary sequence (Figure 13-1). Overcut and undercut draw points provide access to the top and bottom of the stope. Secondary support in the form of inflatable friction bolts and 0-gauge mine straps is installed in the back and sidewalls of the overcut. Support patterns vary based on sequence and adjacent mining (e.g., primary versus secondary stopes). Ring drilling is carried out using a production 75mm top hammer longhole drill. A Machines Roger V-30 boring head is used to drill 30-inch bore holes as slot raises in the stopes. The long-hole drill pattern is designed to contour the stope geometry by using smooth blasting techniques to control wall sloughing and dilution.

After blasting, broken ore is removed from the stope through the undercut drift using a remote controlled load-haul-dump (LHD) unit and loaded into a truck or trammed to an ore pass. When mining is completed, the stope is backfilled with paste fill or cemented rock fill (CRF) for primary stopes and unconsolidated waste rock for secondary stopes. Stope sequencing varies depending on zone, as only a few transverse stopes remain in the mine reserves.

176  
176

Figure STYLEREF 1 \s 13-. Transverse Mining Method

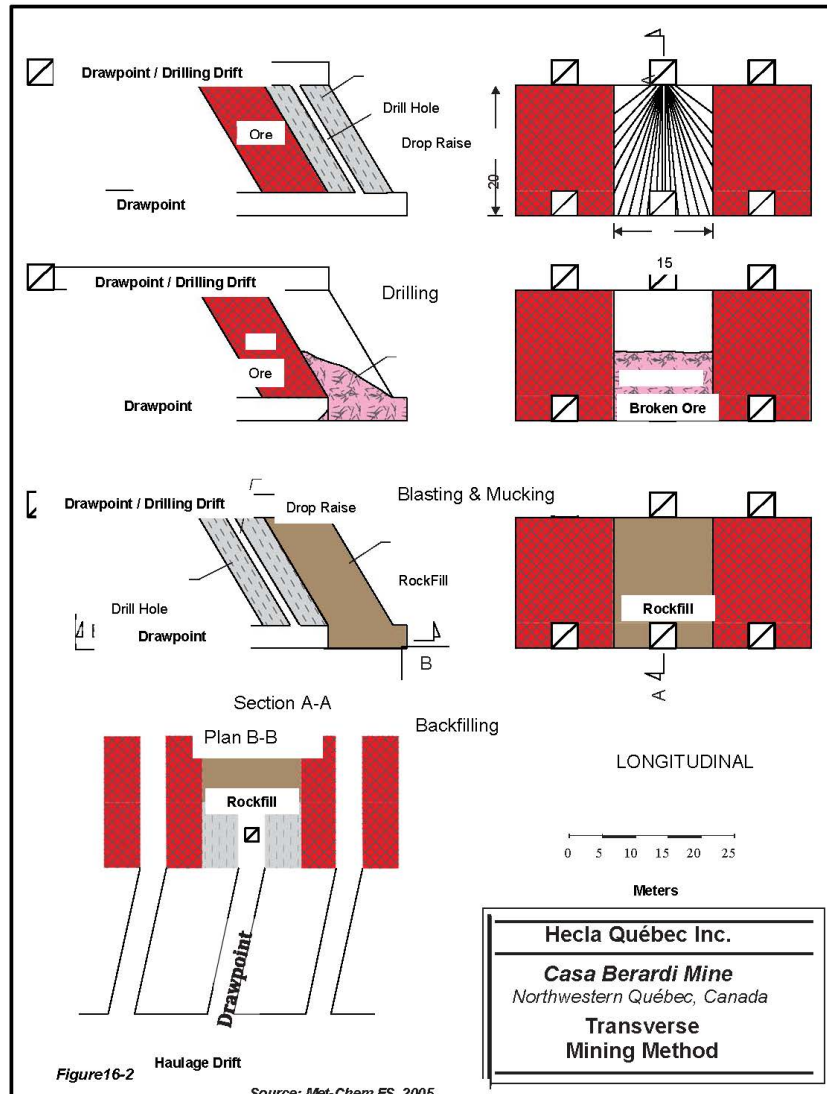

Figure16-2

Source: Met-Chem FS, 2005.

### 13.1.4 LONGITUDINAL METHOD

The longitudinal mining method is used in areas with narrow mineralization or minimal development infrastructure, such as sill development. Oriented along strike, longitudinal stoping is mined in retreat, back towards the access point. Once a stope is mined, it is backfilled with paste fill or a combination of CRF and unconsolidated waste.

Waste development requirements for the longitudinal method are lower than those for the transverse method, as accesses are located within the ore on each level and serve as overcuts and end-muck draw points for subsequent stopes. When compared to the transverse method productivity per level, as measured by sequence and access flexibility, is much lower since only one (i.e., abutment access) or two (i.e., central access) stopes can be mined simultaneously.

### 13.1.5 STOPE SIZE

In general, stope dimensions reflect standard development practices such as draw points on 15m centers and 20m sublevel spacing. When necessary, stope dimensions at Casa Berardi have been reduced in response to local ground conditions, as has been implemented in the 113 Zone, to mitigate sequencing/operational issues and to avoid exposing unconsolidated rock fill.

The remaining ore tonnages by zone are shown in Table 13-1. Stope tonnages will be campaigned through the mill throughout the first half of 2024 to maintain the required 1,240tpd production rate. Mine planning for these stopes considers the full stoping cycle, including providing time for backfill curing. The underground mining operations rely on production from multiple levels and stopes in several zones at any given time.

**Table 13-1. Tonnage per Stope**

<b>Zone</b>	<b>Tonnes (t)</b>
118	151,276
123	50,910
124	2,455
Total	204,641

The typical stoping cycle for Casa Berardi is summarized in Table 13-2.

**Table 13-2. Typical Stope Delays and Activity Duration**

<b>Description</b>	<b>Delay/Duration</b>
Stope Preparation	8 to 10 days
Stope Drilling	2 x 300m (drill) / 3 to 5 days
Stope Blasting & Mucking	3 to 5 days
Stope Filling	7 to 10 days
Stope Curing	14 days (minimum)

### 13.1.6 EAST MINE MINING HISTORY

The East Mine is accessed by a decline from surface to the 650m level. At the 300m level, a track drift connects the East and West mines. The East Shaft is used for a portion of underground services, the hoist has been removed and access via the manway is not currently possible.

In 1997, a partial failure of the Dynatec Plug at the 275m level occurred and resulted in a chimney failure of the Casa Berardi Fault to surface. Following the failure, a ruling from the Commission de la Santé et de la Sécurité au Travail (CSST) suspended underground mining activities at the East Mine. In 2017, based on a technical report and mining plan presented to the CSST, mining activities restarted. Activities included the rehabilitation of the ramp from surface to the 550m level, development of two exploration drifts at the 300m and 485m levels, diamond drilling of the 148 and 160 zones, ramp development below the 550m level, and stope preparation between the 500m and 550m levels.

In 1992, chimney failures along the Casa Berardi Fault resulted in the creation of two craters on surface. Underground, in the 148 Zone mining beneath these craters was isolated by a series of hydrostatic barricades installed between the 90m and 300m levels. The hydrostatic barricades are engineered to prevent inundation by rainwater traveling through the Casa Berardi Fault but are unable to continue to serve as an effective barricade with the addition of clay traveling through the fault. Clay and water inundation in the East Mine has resulted in the decision to close the East Mine.

The EMCP Pit has been mined and backfilled with waste. The waste fill has not mitigated the transmission of surface water (e.g., intense rainfall events and spring thaw) to the underground East Mine. Surface and ground water infiltrating into the East Mine drains primarily via the unconsolidated sand and rock fill of the mined stopes. Since 2017, measures have been implemented to control the drainage and pump the water to maintain a dewatered condition. There are a total of 23 barricades in the East Mine and six in the West Mine. Water valves and pressure gauges are installed on the hydrostatic barricades and monthly inspections are carried out to check for water ingress.

### 13.1.7 BACKFILL

Backfill is required to maximize mineral extraction and maintain stope stability. Three types of backfill are used for the remaining mine life at Casa Berardi: i) unconsolidated waste (rock fill), ii) cemented rock fill (CRF), and iii) paste fill. Rock fill is used in secondary stopes and longitudinal mining where access is no longer required. CRF and paste fill are used primarily in stopes for initial mining horizons which will be eventually redeveloped through the paste fill.

Development waste material is used for rock fill and CRF. Transport of the rock fill to the stopes is by LHDs or trucks. In addition to the stability provided by the rock fill, the use of waste material allows for optimization of the hoisted waste tonnage and equipment utilization by coordinating backfilling in proximity to development areas.

CRF is available throughout the West Mine, including areas above the 470m level where paste fill is not available. A surface plant produces cement slurry in batches, which is transferred underground via a series of boreholes and lateral piping to either a portable cement mixer or directly to the mix pit location.

The CRF is mixed and placed using special mobile equipment. This equipment prepares the cement pulp necessary for the designed CRF mixture.

179  
179

A continuous, gravity-driven paste fill plant was constructed in 2013. The paste fill network can supply paste to the 118, and 123 zones, below the 470m level.

The advantages of paste fill include:

- / Reducing the use of mobile equipment for fill transportation.
- / Allowing better development performance through backfill.
- / Providing better flexibility in the mining sequence.
- / Allowing recovery and subsequent filling of caved stopes.

### 13.1.8 MINE EQUIPMENT

There is an extensive underground fleet of production, development, and support equipment and fixed plant equipment used at Casa Berardi.

The major equipment is:

- / 26 Tonne Haul Truck (1)
- / 40 Tonne Haul Truck (2)
- / 30 Tonne Haul Truck (12)
- / 5.3m LHD (13)
- / 3.1m LHD (2)
- / 4.6m LHD (1)
- / Two boom jumbo face drill (5)
- / Single boom jumbo face drill (2)
- / Long-hole drills (5)
- / Various utility and support equipment (34)
- / Personnel transport equipment (47)

## 13.2 GROUND STABILITY

A history of ground instability and incidents related to mining in proximity to the Casa Berardi Fault at the East and West mines has highlighted the importance of addressing rock mechanics issues for mining at Casa Berardi. Further details regarding specific incidents are described in previous technical reports (SLR, 2022).

### 13.2.1 GROUND CONDITIONS

Ground instability is primarily related to the Casa Berardi Fault system. Lithologies south of the Casa Berardi Fault are composed of relatively weak sediments with a frequent occurrence of schistose and graphitic rocks exhibiting weak contacts. Generally, the rock types vary from massive to fractured and heavily deformed in areas where the mineralization occurs along or near the main structural discontinuities.

180  
180

### 13.2.2 GROUND TESTING AND ANALYSIS

RQD estimation is systematically carried out on all core from diamond drilling and development faces in mineralized material are mapped by the Casa Berardi geology department. The design and approval process for all development headings and stopes includes the analysis of these data on an individual basis.

In situ stress measurements, measured at level 360m and level 430m and carried out in 1999 by Canada Centre for Mineral and Energy Technology, fall within the lower range of the regional trends measured in other hard rock mines of the Abitibi district. Given the relatively weak nature of the rock units at Casa Berardi (i.e., uniaxial compressive strengths of less than 100MPa) there is little evidence of high stress related failures. At depth and in specific zones, such as the 118-06 Zone, however, there is evidence of convergence or squeezing ground deformation. In general, ground stability issues are related to poor ground conditions near faults and gravity-driven wedge failures.

### 13.2.3 OPERATING PRACTICES

Hecla has responded to concerns pertaining to safety and stability of mine openings with the following actions:

- / Minimizing the open stope time, with mucking followed immediately by backfilling. Prioritizing critical stopes for rapid mucking out to minimize exposure of the Casa Berardi Fault. The cement slurry and paste fill plants operate year-round to supply CRF to the mine.
- / Limiting development in the Casa Berardi Fault, particularly the graphite and graphic sediments, by developing perpendicular rather than parallel to the fault.
- / Using pre-support, such as spilling, and support, such as, fiber-reinforced shotcrete arches with mine straps, Inflatable friction bolts, and Friction bolts, with shortened development specifically adapted to fault conditions.
- / Installing recessed cable bolts for hanging wall support, if required, due to ground conditions or development stope geometry.
- / Implementing proactive bolting of walls and intersections using long inflatable friction bolts or cable bolts with mesh straps where required by poor ground conditions or large spans.
- / Controlling of development length (transverse stoping) and heading size (longitudinal stoping) to minimize the creation of overhangs relative to mineral zone geometry in stope top cuts and undercuts.
- / Modifying production drilling for narrow (less than five meter widths) using 65mm diameter drill holes with a 1.5m x 1.5m drill pattern.
- / Changing the drift back profile to an arch configuration to improve the stability of the back.
- / Using standard stope dimensions (average of 15m strike length, 20m high, and up to 20m wide) and based on past mining experience and industry best practices.
- / Application of tight fill. The stope sequence is from the bottom towards the top of each mining horizon / zone, leaving no voids.
- / Locating permanent infrastructure in more stable ground, such as in massive volcanic rocks located to north of the Casa Berardi Fault.

The Casa Berardi ground support measures to maintain drift stability are in accordance with commonly accepted practices. The selected typical stope size and sublevel spacing are conservative, reflect historical best practices, and help maintain stability and minimize dilution. Secondary support is evaluated on a stope-by-stope basis to mitigate

181  
181

unravelling and exposing faults and weaker lithologies or dilution problems. Different types of instruments are installed to monitor the stability of the excavations. These include five meters, 10m, and 15m extensometers (MBPX), SMART cables to monitor the amplitude and depth of rock movement and Sloughmeters, which detect the crack locations following rock displacement.

## 13.3 MINE INFRASTRUCTURE

Mine infrastructure is located in a single area in the West mine. The production and ventilation shafts, shops, WRFs and ore stockpiles, cement plant, paste fill plant, and ramp portal are located at the West Mine. The mill and administration building, crusher, East Shaft (not currently in use), warehouse, and shops are located at the East Mine. Figure 13-2 and Figure 13-3 illustrate each location.

### 13.3.1 WEST MINE SHAFT

Prior to restarting operations in 2006, the shaft at the West Mine was developed. The West Shaft is positioned outside the faults and beyond the zone of stress influence due to mining. The West Shaft design was deepened to the 1,080m level in 2013 and has been operational since 2015.

The West Shaft is a circular 5.5m diameter shaft with a 42m deep concrete shaft collar anchored in bedrock. Shaft stations are located at the 280m, 550m, 690m, 795m, 880m, 1,010m, and 1,030m levels. There are three skip loading stations at the 720m, 835m, and 1,055m levels, a loading pocket at the 880m level and a spill pocket at 1,080m level.

The West Shaft is concrete-lined and equipped with a steel structure that divides the shaft into four compartments. Two compartments are allocated for the 12t skips, each with a cage at the top. The third compartment intended for a service cage for personnel and material is not currently in use. The fourth compartment consists of a manway and a service area for pipes and electrical cables. The headframe is of conventional steel construction, 57m high, incorporating a skip dump arrangement with ore and waste storage bins. The ore bin capacity is 1,200t and the waste bin capacity is 370t.

**Figure STYLEREF 1 \s 13-. West Mine Surface Infrastructure**

183  
183

RSI-M0206.22001

---

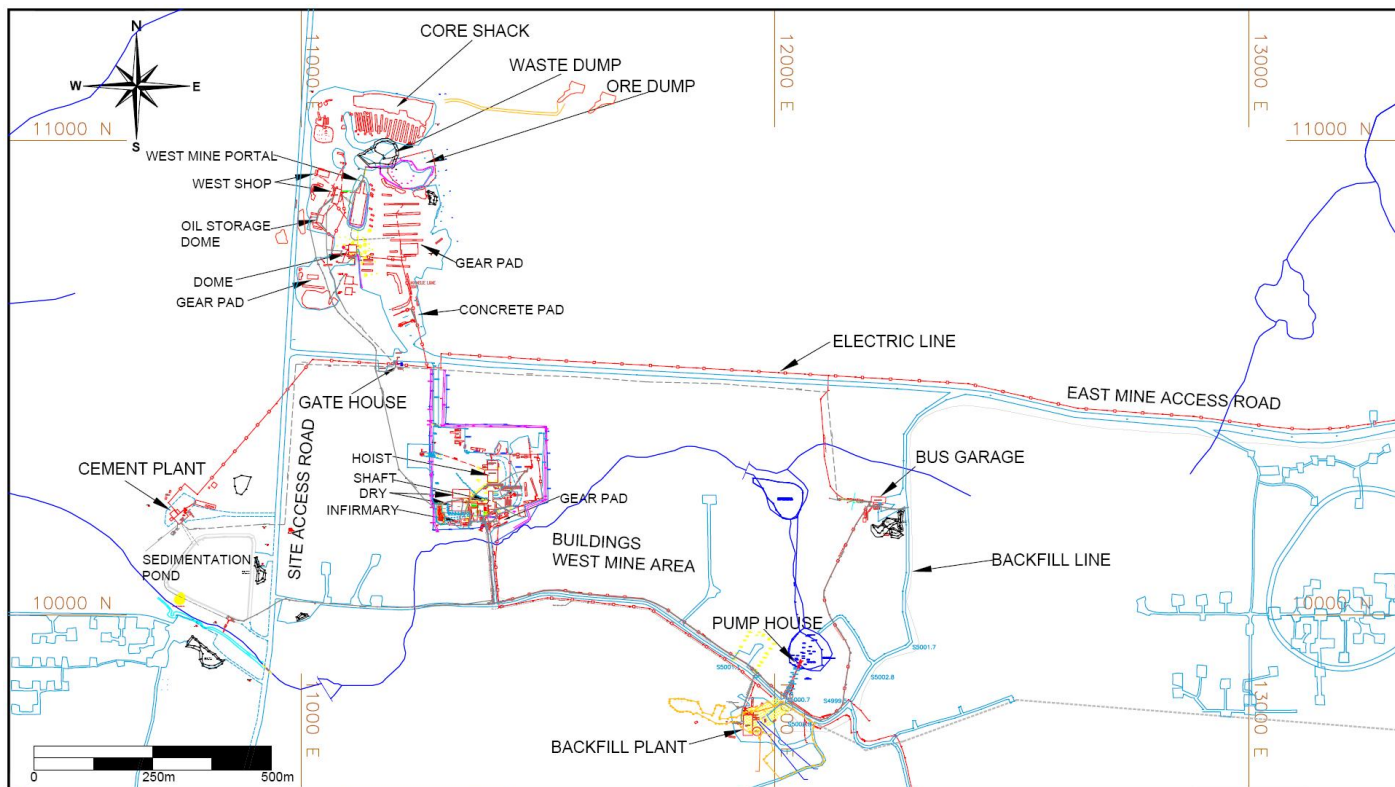

**RESPEC**  
**RESPEC Reno Office**  
 775.856.5700

**Hecla**  
 MINING COMPANY

**CASA BERARDI MINE**  
**QUEBEC CANADA**

<b>West Mine Surface Infrastructure Map</b>
Date: 25 January 2024
Scale: As Shown
Coordinate System: Local Mine Grid - Meters

184  
 184

**Figure STYLEREF 1 \s 13-. East Mine Surface Infrastructure**

185  
185

RSI-M0206.22001

---

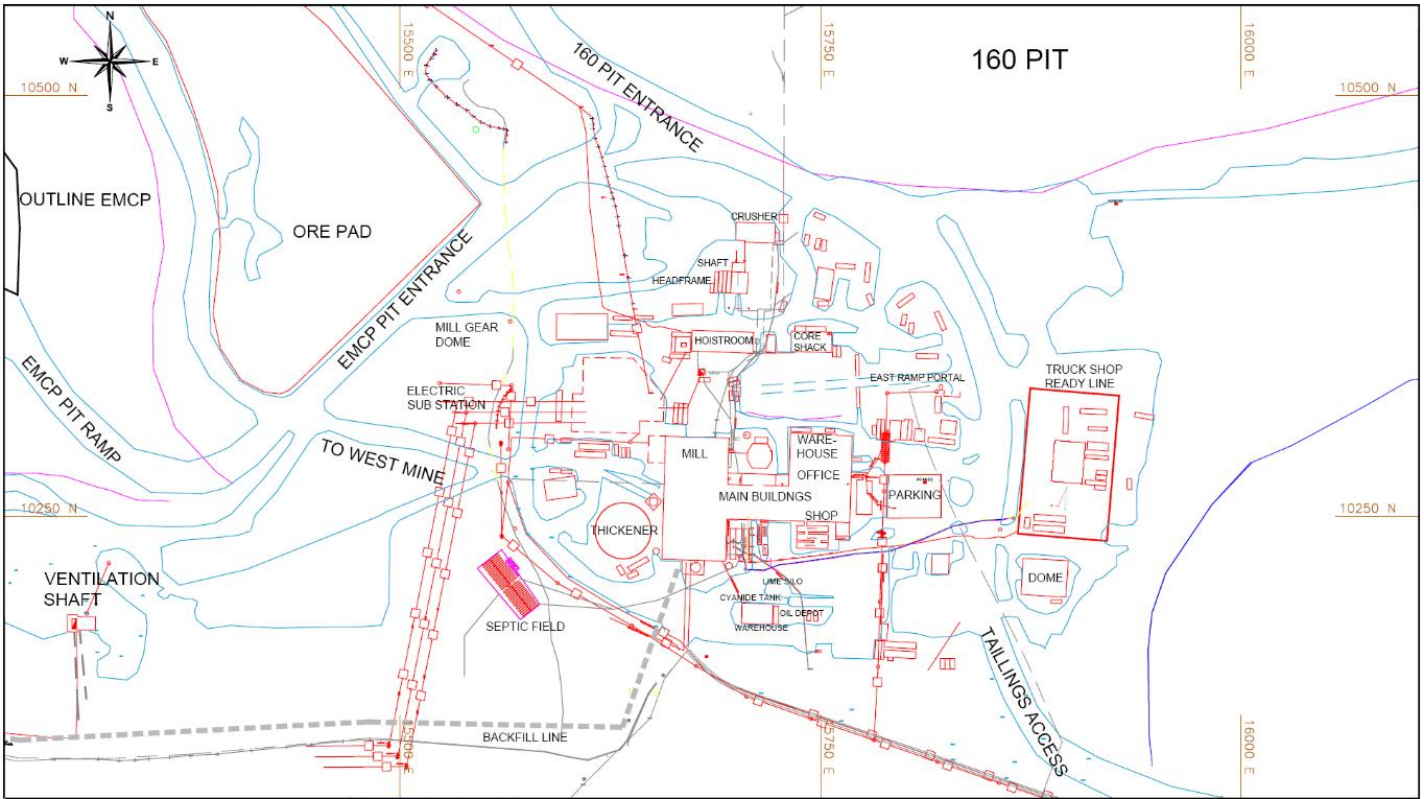

**RESPEC Reno Office**  
775.856.5700



**CASA BERARDI MINE  
QUEBEC CANADA**

**East Mine Surface Infrastructure  
Map**

Date: 30 January 2024
Scale: As Shown
Coordinate System: Local Mine Grid - Meters

186  
186

### 13.3.2 ORE AND WASTE PASS SYSTEMS

The ore and waste pass systems were sized and located according to the production requirements of the 113 and Lower Inter zones, which are no longer in production. Ore and waste passes are 2.4m in diameter.

The 118 and 123 zones, ore and waste passes terminate on the 985m level automated drift. The ore pass connection in the 123 Zone (550m to 985m levels) was completed in 2019. Two automated trucks transport material from the automated chutes to automated rock breaker on 985m level which is controlled from surface. The ore and waste pass systems on the 985m level terminate at the 1,055m level loading pocket. From the 1,055m level loading pocket, ore and waste are skipped to surface.

For the 124 Zone, all the material is brought to the surface by trucks. Ore and waste are transported to their respective dumps by LHD. Oversize material is handled by a rock breaker or moved to a suitable location for secondary blasting.

### 13.3.3 VENTILATION

The ventilation network design was based on physical mine configurations and accounts for the production rate, installed horsepower on diesel equipment, number of personnel, and simultaneous activities underground.

The main ventilation raises for mine air distribution system are 3.35m in diameter, excavated by a raise climber (Alimak) from the lower levels of each zone and connected with main airways. Raise ventilation access drifts (up to 10m long) are excavated on each level/sublevel during raise development and connected to the main haulage drifts when accessed later. A ventilation schematic circuit is presented in Figure 13-4.

187  
187

**Figure STYLEREF 1 \s 13-. West Mine - Ventilation Schematic Circuit**

188  
188

RSI-M0206.22001

---

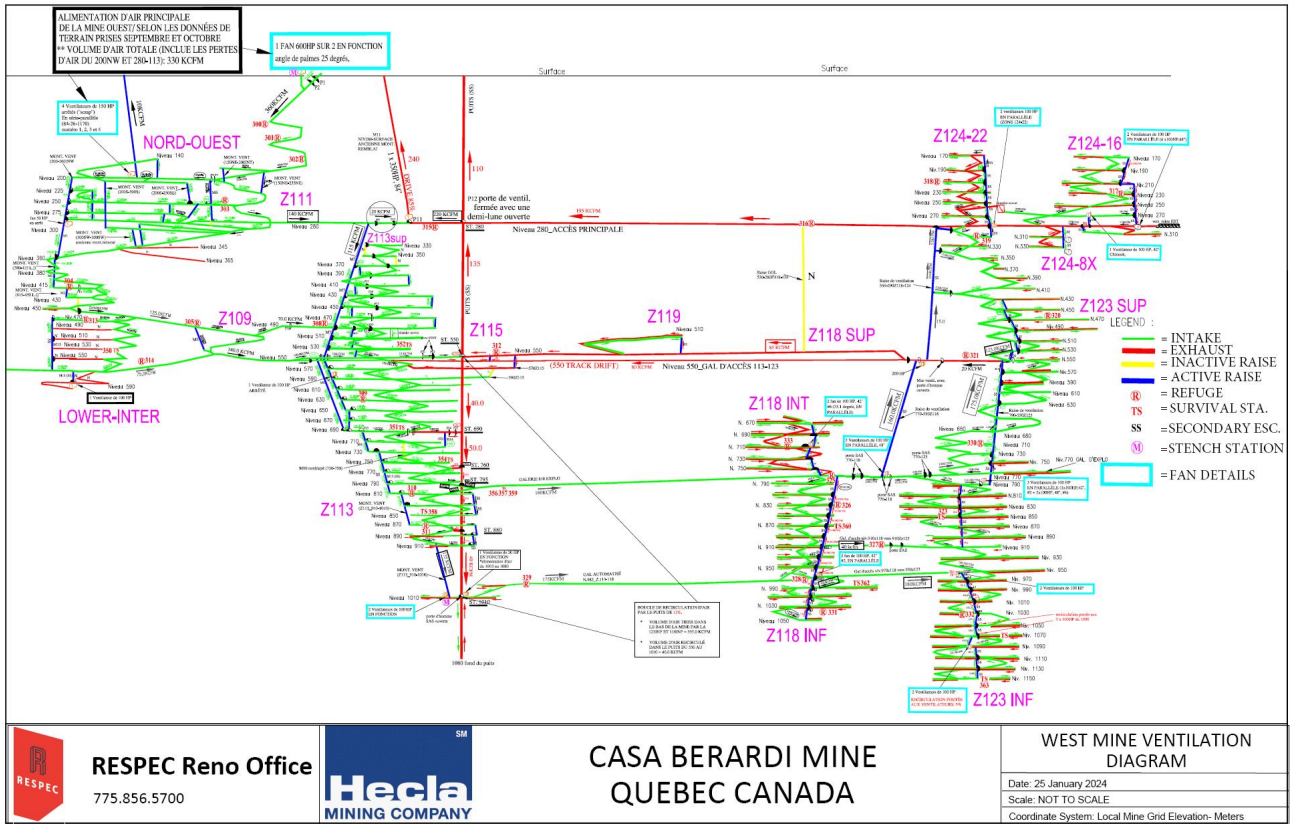

The Mine requires 465,000 cubic feet per minute (cfm) at full production capacity. The ventilation network installations at the mine consist of:

- / The fresh air intake system, which is comprised of two fans in parallel installed at the West Mine portal. These fans are able deliver up to 600,000cfm of fresh air through the West Mine Principal ramp with an air lock system. The operating static pressure is 6.5in of water.
- / The West Mine exhaust air points are the shaft and an old backfill raise.
- / Numerous installed airflow regulators, booster fans, and ventilation raises.
- / Due to broken fans the second fresh air intake system was downgraded; however, it remains an option to increase flexibility and the capacity of ventilation if needed. The second fresh air system had the potential of four 112kW (150hp) fans, and could provide 123m<sup>3</sup>/s (260,000cfm) airflow at an operating static pressure of 8.5in of water.

#### 13.3.4 MAINTENANCE FACILITIES

The main fixed equipment, both on surface or underground, such as the hoist, compressors, ventilators, GEHO pumps, and cement plant, are covered by an integrated preventive maintenance program. Daily maintenance and parts replacement is completed on site. Major equipment overhauls are conducted off site in specialized maintenance shops.

The maintenance of mobile equipment, used on surface and underground, is conducted in a building located near the mill at the East Mine. This building includes a maintenance shop, warehouse, offices, a change room, and a communications system. The existing surface shop is well equipped (compressed air, lifting equipment, cranes, and welding facilities) and large enough to accommodate equipment employed at the site.

The warehouse is located nearby and facilitates the delivery of parts and materials for maintenance and repairs. Spare tires are stored on a nearby pad. The change room and sanitation facilities are located on the second floor of the building.

To improve the maintenance time and displacement of equipment, Hecla Québec installed an underground garage on the 550 Level, in 2010.

Another underground garage was completed in 2014 on the 810 Level, close to the 118 and 123 zones. Prior to developing the next open pit, new surface maintenance facilities will be expanded.

#### 13.3.5 POWER

Electrical power is supplied to site by Hydro-Québec through a 120kV line from the town of Normetal (55km to the southwest). Two main transformers are installed in the main substation, located at the East Mine site. The East Mine site is supplied by a 120kV/4.16kV – 16 MVA transformer (T1) and the West Mine site is supplied by a 120kV/25kV – 20 MVA transformer (T2) as presented on the electrical single-line diagram (Figure 13-5, Figure 13-6).

The East Mine site distribution network supplies the mill, EMCP Pit and garage.

The West Mine site employs a 25kV line network supplies the West Mine portal main ventilation fan, the headframe, hoist, shaft collar, and compressor buildings, West Mine facilities, and a 5kV transformer to supply 1,000kVA to underground substations in the mining areas. A 25kV underground station supplies 1,000kVA to substations in the 118 and 123 zones.

Underground power distribution is via cables installed in the West shaft or in the ramp. Power supply in Québec is very reliable. Hecla provides backup power for the West Mine headframe (135kW), the surface garage (350kW), the mill (525kW), and the West Mine backfill plant (200kW).

191  
191

RSI-M0206.22001

---

Figure STYLEREF 1 \s 13-. Casa Berardi Main Station 120kV Flowsheet

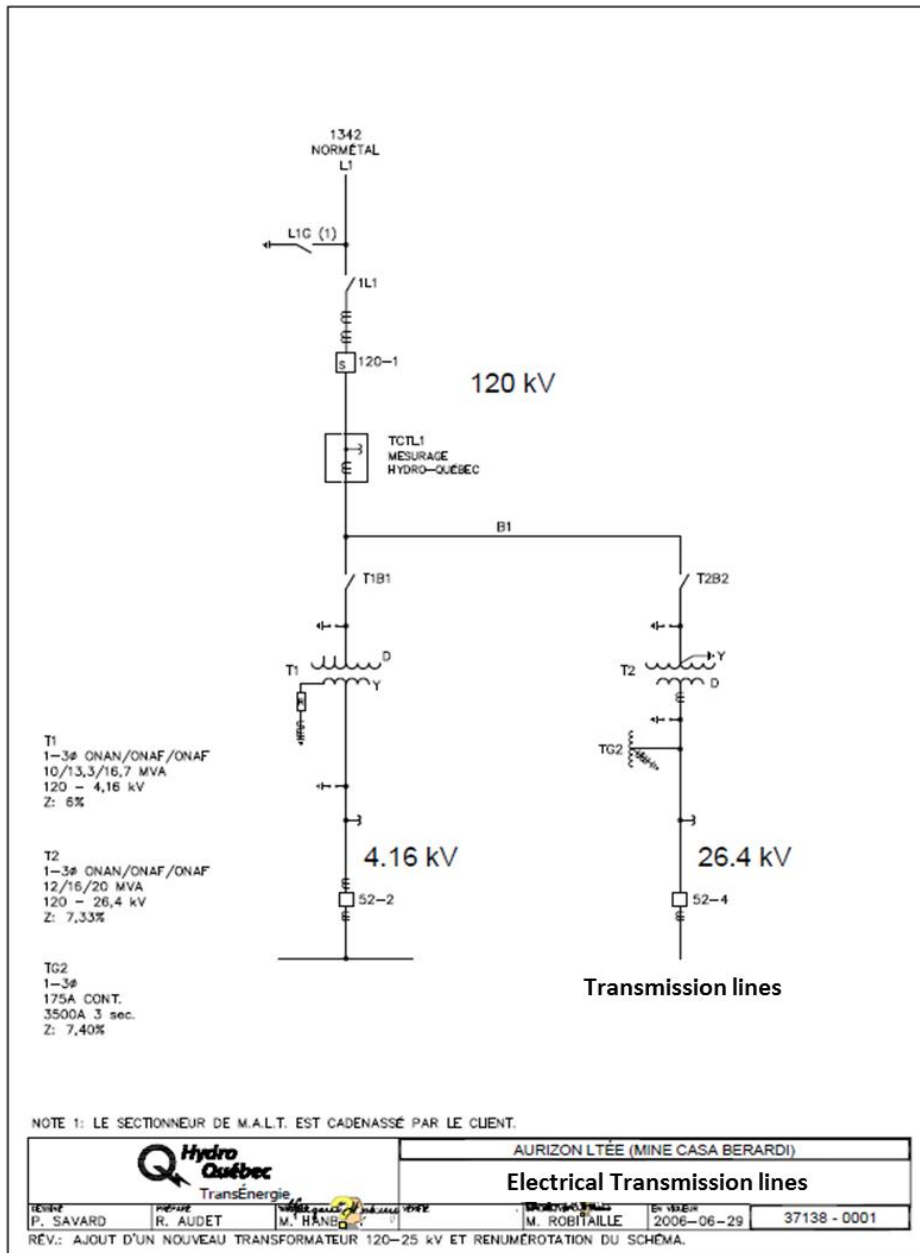

### 13.3.6 PERSONNEL

The Casa Berardi workforce consists of company personnel and contractors. The Hecla personnel and contractor lists for mining operations at Casa Berardi are presented in Table 13-3.

193  
193

**Table STYLEREF 1 \s 13-. Personnel Requirements by Year**

	2024	2025	2026	2027	2028	2029	2030	2031	2032	2033	2034	2035	2036	2037
Plan Employees	541	251	251	162	147	148	178	252	252	252	252	252	247	238
UG Mine	184	0	0	0	0	0	0	0	0	0	0	0	0	0
OP Mine	79	85	85	16	85	85	85	85	85	85	85	85	85	85
UG Maint	78	0	0	0	0	0	0	0	0	0	0	0	0	0
OP Maint	25	25	25	11	20	20	22	25	25	25	25	25	25	25
Mill	91	84	84	84	0	0	22	84	84	84	84	84	83	82
GA	84	57	57	51	42	43	49	58	58	58	58	58	54	46
Plan Contractor	295	103	103	83	83	103	103	103	103	103	103	103	103	103
Total	836	354	354	245	230	251	281	355	355	355	355	355	350	341

194  
194

The number of Hecla employees required for the Casa Berardi mining operation is expected to decrease in 2025 after the closing of the underground operation. Additionally, the number of personnel required will dip in 2027 through 2030 as surface mining pauses during a mill expansion. The number of contractors varies year to year depending on labor requirements at the mine.

Underground production and lateral development is carried out by Hecla personnel, while contractors conduct vertical raise development. Some contractor personnel are utilized in the processing plant, core logging facilities, maintenance, and surface drill and blast operations. Operators and technical staff work a schedule consisting of seven days of dayshift, seven days of nightshift, and seven days off. General staff work on a four day on, three day off shift cycle.

## 13.4 OPEN PIT MINING OPERATIONS

Open pit operations at Casa Berardi began in January 2016, in the EMCP Pit. This TRS considers the planned F160, Principal, WMCP, and F134 pits. These open pits involve both the recovery of crown pillars above underground mining (i.e., WMCP, and Principal pits) and mining of zones that have not been exploited underground (i.e., F160 and F134 pits).

### 13.4.1 MINING METHOD

Material is mined using conventional open pit mining methods, based on a truck/shovel operation. The rock is drilled, blasted, and loaded by hydraulic shovels into trucks, which deliver the material to a stockpile located near the primary crusher. Distances from the top of the ramp to the ore stockpile range from 300m (F160) to 5000m (WMCP).

Waste materials generated by mining include overburden (i.e., peat, clay, till and sand), waste rock (i.e., clean and low-grade mineralized) and backfill from stopes intercepted during mining (i.e., unconsolidated sand and rock fill). The overburden material is removed and hauled to the Mixed WRF, while peat is stored separately for restoration-revegetation. Higher quality clay has been used for tailings dams, isolation levees and reclamation projects (e.g., cover of tailings in preparation for revegetation). Clean waste rock is used for surface infrastructure work such as roads, levees, tailings dams and foundations for civil engineering constructions. A portion of the clean waste rock is crushed and screened to provide aggregates for roadway construction and maintenance, and for use as abrasives in icy weather conditions. Low-grade material (below cutoff grade) is stockpiled in a different location than the ore. Stope backfill is hauled to the Mixed WRF.

### 13.4.2 OPEN PIT DESIGN

F160 Pit designs employ 7.5m high mining benches, with a catch berm positioned every two benches (i.e., 15m). This allows greater flexibility in regard to blast tonnage and control on pre-shear blasting and excavation of final pit walls. For future pits, 10m high mining benches are designed to optimize production rates. The F160 pit has been mined in phases, with an additional pushback planned.

### 13.4.3 SLOPE PARAMETERS – OVERBURDEN

Overburden slope parameters are based on recommendations from previous geotechnical and mining studies (Itasca, 2020), (Golder, 2009) and (BBA, 2011). The overburden slope parameters vary as function of material type:

195  
195

/ Slopes in clay: 4H:1V (14.1°) – 3H:1V (18.4°).

/ Slopes in till: 2H:1V (26.6°).

In 2018, Hecla re-evaluated the 4H:1V slope angle in the clay material based on in situ observations and data from previous geotechnical characterizations using Rocscience's Slide 7.0 software (Hecla, 2018). Based on this analysis, the use of 4H:1V slopes in clay were demonstrated to be conservative and 3H:1V slopes were proved to be stable. As a result, the east and south overburden slopes of the EMCP Pit were excavated according to Golder Associates Inc.'s (Golder) (2009) recommendation of 4H:1V in clay. The north and west slopes, however, were excavated using a 3H:1V slope in clay. Inclinometers and prisms installed in the overburden confirm the stability of 3H:1V slope in the clay material. A part of the slopes in the EMCP Pit are covered with one meter of waste rock to prevent erosion.

Experience gained from the excavation of overburden in the EMCP Pit has demonstrated that information related to the bedrock-overburden contact was limited to drill hole locations. Although the surface topography is relatively flat, the bedrock contact varies significantly across the site and particularly above the Casa Berardi Fault. At this location the bedrock forms a valley which varies from approximately 40m below surface at the west end of the mine site to 50m below surface at the east end. On either side of the Casa Berardi Fault, the bedrock elevation is higher, rising to 20m below surface on the south side. The variation in the expected contact position (i.e., overburden thickness and topographic bench elevation) has required the Casa Berardi engineering personnel to modify the design in order to compensate for higher or lower pit wall positions.

For the F134, F160, WMCP, and Principal pits, the designs are based on a 3H:1V (14.1°) to 3.5H:1V (15.9°) slope in the clay and sand, and a 2H:1V (26.6°) in the till.

#### 13.4.4 SLOPE PARAMETERS - ROCK

The slope parameters for the final pit wall in the rock are:

/ An Inter Ramp Angle (IRA) of 52.5°.

/ A Bench Face Angle (BFA) of 75°, over a 15m height or two 7.5m high benches in F160 and over a 20m height or two 10m high benches in the remaining pits.

/ A 7.5m wide catch berm every 15m in elevation for F160 and a 10m wide catch berm every 20m in elevation for the remaining pits.

#### 13.4.5 RAMP DESIGN

Ramps for the F160 pit were designed with a nominal 10% centerline gradient. Switchbacks were designed with a centerline gradient of 8% to prevent the inside curvature gradient from becoming excessive. Ramp widths assume the use of rigid-body haul trucks with a width of 5.6m, although articulated trucks are planned to be used for overburden and may be used in other areas as needed. A 25.0m width was used for ramps with two-way traffic. This provides for a running width of three times the truck operating width and includes a 1.1m high safety berm. In the lower portions of the pit designs, where the stripping ratio is minimal, ramps were narrowed to 14.5m for one-lane traffic use.

Same parameters apply for the Principal, WMCP, and F134 except for the width. The ramps are 27m width because they are designed for 150-tonne rigid-body with an operating width of 7.0m and includes a 1.45m high safety berm. As in F160, one-lane ramp ramps were utilized with a minimum width of 17.0m.

196  
196

#### 13.4.6 UNDERGROUND WORKINGS

The previous EMCP Pit intercepted underground openings in the pit floor. These openings include unfilled drifts and raises, as well as backfilled stopes. Stope backfill is unconsolidated sand and rock fill. These excavations are largely isolated from the accessible areas of the underground East Mine by a series of hydrostatic barricades. The same types of openings will be encountered in the Principal and WMCP pits.

Procedures are in place for the definition of safety perimeters for specific mining activities, such as drilling, loading, and excavating, and for the movement of vehicles and personnel in proximity to these excavations or their remaining crown pillars. The use of C-ALS surveys and production drilling data (e.g., breakthrough locations) are used to confirm the survey data and 3D models of the underground excavation. To date, no issues have been encountered related to the underground excavations. Underground mining is planned to be completed prior to the start of Principal and WMCP.

The F134 and F160 Pit projects will not intersect any underground excavations. These open pits are considered to have no impact on simultaneous underground operations and do not require any special precautions to be taken.

#### 13.4.7 OPEN PIT MINING EQUIPMENT

Mining equipment is currently operated and maintained by a contractor until 2024. The current equipment fleet is summarized in Table 13-4. The projected Owner equipment fleet is summarized in Table 13-5.

197  
197

**Table STYLEREF 1 \s 13-. Mine Equipment List Open Pit**

<b>Equipment Type</b>	<b>Nominal Capacity</b>	<b>Contractor Fleet (Actual)</b>	<b>Hecla Fleet (Actual)</b>	<b>Hecla Fleet (Peak)</b>
Hydraulic excavator	7.0m <sup>3</sup>	2	1	2
	3.5m <sup>3</sup>	2	-	-
	2.3m <sup>3</sup>	-	2	2
	1.8m <sup>3</sup>	2	-	-
	3.1m <sup>3</sup>	2	-	-
	2.0m <sup>3</sup>	1	-	-
Front-end loader	11.5m <sup>3</sup>	-	1	2
	7m <sup>3</sup>	-	2	2
	3.2m <sup>3</sup>	-	1	1
	4.4m <sup>3</sup>	1	-	-
Rigid-frame truck	92.2t	-	4	13
	63.0t	8	-	-
Articulated truck	55.0t	-	4	4
	41.0t	14	-	-
Dozer	360hp	-	2	4
	325hp	2	-	-
	215hp	2	-	-
Grader	5.5m	-	2	2
	4.3m	3	-	-
Mechanic service truck		2	1	4
Water truck		2	1	2
Fuel truck		2	1	1
Sand truck		-	1	1
Flatbed truck		1	1	1

#### 13.4.8 GEOTECHNICAL/HYDROGEOLOGICAL CONSIDERATIONS

The general soil stratigraphy encountered in geotechnical boreholes varies from east to west across the Property, grading from an esker, composed predominately of granular material (in vicinity of the Principal Pit), to a stratified cohesive deposit over glacial till. The esker has been identified over more than 75km, with a north-south orientation. A geotechnical study (Golder, 2010) confirmed the occurrence of the esker within the vicinity of the preliminary Principal Pit, where the thickness may reach more than 50m. Golder (2010) did not, however, allow for the identification of the esker limits, which have later been defined in more detail by others.

The presence of the esker in the vicinity of the preliminary Principal Pit may potentially result in inflows and groundwater contamination during project operations. The primary source of potential contamination being the leaching of metals into groundwater, primarily arsenic, from the waste rock pile.

During 2021, SRK Consulting (Canada) Inc. (SRK), carried out a hydrogeology field investigation program (SRK, 2021) to install piezometers and evaluate conditions for the WMCP, Principal, F134, and F160 pits. This program followed up with numerical groundwater modelling of the Principal Pit for passive inflow predictions and made recommendations to manage expected inflow rates during mining. One of the key recommendations proposed was to commence pumping approximately 18 months prior to the start of mining to reduce the ongoing pumping rate during the mining operations. Stripping of the Principal Pit is scheduled to commence in 2024. The final eight years of mine production will come from the Principal Pit followed by the WMCP Pit and it will be essential to maintain efficient dewatering during this period.

The list of studies carried out for the Casa Berardi underground mines to address geotechnical, geomechanical, hydrological, and hydrogeological conditions are indicated in. Similar studies carried out for the surface open pit mines are summarized in Table 13-5.

**Table STYLEREF 1 \s 13-. Geotechnical, Geomechanical, Hydrological and Hydrogeological Studies (Underground Mines)**

Study	Year	By	Type	Objective	Results Summary	Report Reference Name
West Mine						
1	1999	CANMET	Geomechanics	In situ stress measurements	Stress measurements were taken at two locations in the West Mine, providing the regional stress tensor.	Canmet (1999)
2	2017	Hydro-Resources	Hydrogeology	Crown Pillar	Determined hydrological properties in the WMCP situated above the underground principal zone and identified prominent water bearing faults.	Hydro-Resources Inc. (2017)
3	2019	Hecla	Geomechanics	Ground Control Management Plan (GCMP)	Establishes common procedures developed for identifying, evaluating, communication and monitoring geotechnical risks (developed by Hecla).	Hecla Québec (2019)
4	2019	Hecla	Geomechanics	Backfill	Demonstrated the backfilling requirements for plug and mass strengths.	Alcott et al. (2019)
East Mine						
1	2015	Hecla	Geomechanics	Reopening East Mine Operations	Demonstrated the impact of mining the lower East Mine on the surface.	Hecla Québec (2015)
2	2019	Hecla	Geomechanics	GCMP	Establishes common procedures developed for identifying, evaluating, communicating and monitoring geotechnical risks (developed by Hecla).	Hecla Québec (2019)

**Table STYLEREF 1 \s 13-. Geotechnical, Geomechanical, Hydrological and Hydrogeological Studies (Open Pit Mines)**

Study	Year	By	Type	Objective	Results Summary	Report Reference Name
EMCP Pit						
1	2020	Itasca	Geomechanics	Slope Angle In Rock	Determined the optimal slope angles in rock, based on oriented core drilling/logging and additional rock laboratory tests.	Itasca (2020)
2	2017	Hydro-Resources	Hydrogeology	Water Table	Established the water state in/near the EMCP, demonstrating the draining capability of the East Mine (under draining the clay overburdens).	Hydro-Resources Inc. (2017)
3	2018	Hecla	Soil	Slope Angles in Overburden	Confirmed slope angles in overburden based on operational observations, recalibrated to numerical modeling response.	Hecla Québec (2018)
4	2019	Hecla	Geotechnical	GCMP	Establishes common procedures developed for identifying, evaluating, communication and monitoring geotechnical risks (developed by Hecla).	Hecla Québec (2019)
F160 Pit						
1	2013	Golder	Geomechanics	Slope Angle in Rock	Determined the preliminary slope angles in rock, based on oriented core drilling/logging and numerical modeling.	Golder (2013)
2	2019	Hecla	Geotechnical	GCMP	Establishes common procedures developed for identifying, evaluating, communication, and monitoring geotechnical risks (developed by Hecla).	Hecla Québec (2019)

201  
201

Study	Year	By	Type	Objective	Results Summary	Report Reference Name
3	2021	ConeTec	Soil	Determining Soil Strength Properties	Factual report establishing soil strength properties thru seismic piezocone penetration testing (SCPTU).	ConeTec (2021)
4	2020	Itasca	Soil	Slope Angles in Overburden	Numerical analysis of slope angle in clay, for saturated overburden conditions.	Itasca (2020)
5	2020	Hydro-Resources	Hydrogeology	Water Table	Preliminary assessment of the water table near the F160 Pit, with a crude assessment of well locations to depressurize the till overburden layer.	Hydro-Resources Inc. (2020)
6	2021	SRK	Hydrogeology	Gap Analysis for Hydrology and Hydrogeology	Performed a gap analysis, reviewing all relevant past studies, to establish future requirements to meet permitting and/or feasibility level designs.	SRK (2021a)
7	2021	SRK	Soil	Gap Analysis for Geotechnical Soil and Stratigraphy	Performed a gap analysis, reviewing all relevant past studies, to establish future requirements to meet permitting and/or feasibility level designs.	SRK (2021e)
8	2021	SRK	Rock	Gap Analysis for Geomechanical Rock Stability	Performed a gap analysis, reviewing all relevant past studies, to establish future requirements to meet permitting and/or feasibility level designs.	SRK (2021g)
9	2021	SRK	Hydrogeology	Hydrogeology in Rock	Determined the permeability of the rockmass.	SRK (2021f)
Principal Pit						
1	2011	Golder	Soil	Slope Angles in Overburden	Initial numerical analysis of slope angle in clay, for saturated overburden conditions.	Golder (2011)

202  
202

Study	Year	By	Type	Objective	Results Summary	Report Reference Name
2	2020	Geophysiqhe Sigma	Soil	Overburden Thickness and Stratigraphy	Established, thru geophysics, overburden thickness/stratigraphy in the Principal zone.	Geophysiqhe Sigma (2020)
3	2021	ConeTec	Soil	Determining Soil Strength Properties	Factual report establishing soil strength properties thru SCPTU.	ConeTec (2021)
4	2021	SRK	Hydrogeology	Evaluate the Passive Ground Water Inflow into the Principal Pit	Established the esker's hydrological characteristic (drawdown and zone of influence) thru long term pump tests and evaluated the preliminary pumpability performance. Related the observation to numerical modeling to forecast passive inflows of groundwater into the Principal Pit, per extraction phase.	SRK (2021a)
5	2021	SRK	Hydrogeology	Gap Analysis for Hydrology and Hydrogeology	Performed a gap analysis, reviewing all relevant past studies, to establish future requirements to meet permitting and/or feasibility level designs.	SRK (2021b)
6	2021	SRK	Soil	Gap Analysis for Geotechnical Soil and Stratigraphy	Performed a gap analysis, reviewing all relevant past studies, to establish future requirements to meet permitting and/or feasibility level designs.	SRK (2021e)
7	2021	SRK	Rock	Gap Analysis for Geomechanical Rock Stability	Performed a gap analysis, reviewing all relevant past studies, to establish future requirements to meet permitting and/or feasibility level designs.	SRK (2021g)
8	2021	SRK	Hydrogeology	Hydrogeology in Rock	Determined the permeability of the rockmass.	SRK (2021d)
WMCP Pit						

203  
203

Study	Year	By	Type	Objective	Results Summary	Report Reference Name
1	2020	ConeTec	Soil	Determining Soil Strength Properties	Factual report establishing soil strength properties thru SCPTU.	ConeTec (2021)
2	2021	SRK	Hydrogeology	Gap Analysis for Hydrology and Hydrogeology	Performed a gap analysis, reviewing all relevant past studies, to establish future requirements to meet permitting and/or feasibility level designs.	SRK (2021a)
3	2021	SRK	Soil	Gap Analysis for Geotechnical Soil and Stratigraphy	Performed a gap analysis, reviewing all relevant past studies, to establish future requirements to meet permitting and/or feasibility level designs.	SRK (2021h)
4	2021	SRK	Rock	Gap Analysis for Geomechanical Rock Stability	Performed a gap analysis, reviewing all relevant past studies, to establish future requirements to meet permitting and/or feasibility level designs.	SRK (2021g)
5	2021	SRK	Hydrogeology	Hydrogeology in Rock	Determined the permeability of the rockmass.	SRK (2021d)

#### 13.4.9 MATERIAL MANAGEMENT

Over the LOM, open pit operations will generate over 234Mt of material. This material will be comprised of overburden, ore, low-grade material, clean waste and backfill, and will be extracted from up to three different open pits at any one time at different stages of development.

Owing to the complexity associated with handling different types of material with different pits, a robust production plan needs to be supported with a robust waste management program. Casa Berardi's LRP has been built to manage the infrastructure material quantities. Shortage in any type of material could have negative effects on the mine plan if critical infrastructure cannot be put into place in a timely manner. Correcting these shortages will also result in increased costs which would be difficult to control. Accordingly, the construction of WRF infrastructure has been scheduled to start when building materials are available, as opposed to when a need for storage arises. At this time, different scenarios are being studied regarding the waste rock disposal. The current plan is to utilize backfilling in EXCP/XMCP and Principal as well as the creation of a WRF in the north of the property.

204  
204

#### 13.4.10 WASTE ROCK CHARACTERIZATION

Maxxam Analytical Laboratory performed the following tests on waste rock samples:

- / Acid generation potential.
- / Metal content (partial digestion).
- / Leaching according to EPA-1311 test method (acetic acid).
- / Leaching according to EPA-1312 test method (nitric and sulfuric acid – acid rain).
- / Leaching according to CTEU-9 test method (water).

Based on these analyses, the waste rock has been identified as non-acid generating but has been classified as leachable according to the Québec Directive 019 criteria.

RESPEC notes, however, that the contents measured are below the criteria for the classification as a high-level risk mining waste.

The waste rock has been classified in two distinct categories, clean and low-grade mineralized. Clean waste rock can be used for construction, however, low-grade mineralized material cannot. Low-grade mineralized material is defined as the 10m envelope of material surrounding mineralization. This material must be buried with either clay or clean waste rock, at the Mixed WRF, to prevent it from being in contact with the air.

#### 13.4.11 WASTE ROCK FACILITY LOCATIONS AND CONSTRUCTION

The following criteria have been used for the selection of potential waste rock and overburden storage sites:

- / Avoid material storage over wetlands (loading capacity).
- / Avoid material storage in streams and surface water bodies.
- / Limit transport distance within the mining pit.

Mixed WRFs have been designed as an engineered waste disposal complex capable of containing low cohesive material such as clay materials. The Mixed WRF uses a crown shape infrastructure, that acts as recipient for the clays. Low-grade mineralized waste rock and till are used to build containment cells within the crown. Each cell is accessed by a series of temporary roadways and dumping fronts, constructed using waste rock. These temporary infrastructures are ultimately buried in clay or covered by clean waste rock, as the WRF is finally capped, in the last step before full reclamation. The construction of the Mixed WRF is strictly controlled to allow for uniform deposition of waste materials in one meter lifts over its entire footprint.

In addition to the existing Mixed WRFs #1, #2, and #3, located to the southeast of the EMCP Pit, preliminary Mixed WRF facilities are planned, in the vicinity of the preliminary WMCP and Principal pits. Final locations, capacity, and configurations have not been finalized and will depend on future long-term mine plans.

Figure 13-6 presents a general plan of the Casa Berardi site and indicates the location of the actual WRF complex (i.e., HM3) and the preliminary WRF sites (i.e., HMF). Whenever possible, waste will be used to backfill the open pits that have been exhausted. Currently the operation is backfilling the EMCP Pit and backfilling of the Principal Pit is planned for 2033. Approximately 40Mt of material extracted from the WMCP Pit will be used to backfill the Principal Pit. Backfilling of the open pits will depend on the timing of their completion and on the haulage distances between the WRF site and the active pit. Figure 13-9 describes the dumping sequence as a function of material type for each open pit projects.

**Figure STYLEREF 1 \s 13-. Open Pit and Waste Rock Locations**

206  
206

RSI-M0206.22001

---

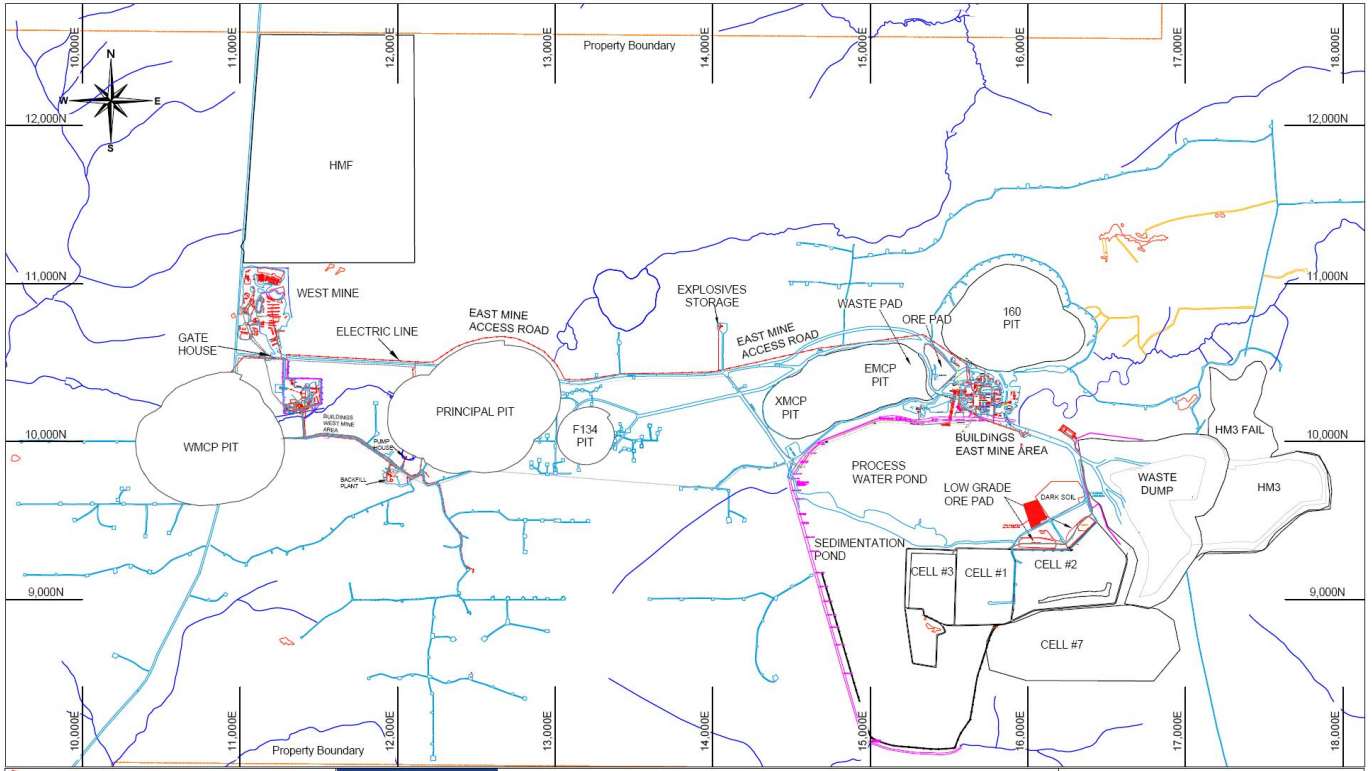

	<b>RESPEC Reno Office</b> 775.856.5700		<b>CASA BERARDI MINE</b> <b>QUEBEC CANADA</b>	Casa Berardi Mine Surface Infrastructure Map Date: 31 January 2024 Scale: As Shown Coordinate System: Local Mine Grid - Meters
--	---	--	--	--

207  
207

RSI-M0206.22001

Table STYLEREF 1 \s 13-. Dumping Sequencing

Area	Material	2022	2023	2024	2025	2026	2027	2028	2029	2030	2031	2032	2033	2034	2035	2036	2037
EMCP-EXF	Overburden																
	Rock Waste		MH3/EM CP fill	EMCP fill													
F134	Overburden																
	Rock Waste																
F160	Overburden	MH3/EM CP fill	MH3/EM CP fill	EMCP fill													
	Rock Waste	MH3/EM CP fill	MH3/EM CP fill	EMCP fill	MHF/EM CP fill	MHF/EM CP fill	MHF	MHF									
WMCP	Overburden							MHF	MHF	MHF	MHF						
	Rock Waste							MHF	MHF	MHF	MHF	MHF	PRIN fill	PRIN fill	PRIN fill	PRIN fill	PRIN fill
PRINCIPAL	Overburden				MHF	MHF	MHF	MHF									
	Rock Waste					MHF	MHF	MHF	MHF	MHF	MHF						

208  
208

The design criteria for the WRFs are to:

- / Maximize capacity based on the bearing capacity of the ground, to reduce the environmental impact of the WRF footprints on the site.
- / Whenever possible, backfill completed open pits. It must be noted that hauling distances have a major impact on the economic viability of the open pit projects. Some open pits will be left unfilled, owing to uneconomical hauling distances.
- / Optimize pit scheduling to allow waste materials generated by mining to be used for the dump site infrastructure (e.g., access roads).
- / When backfilling open pits that intersect underground excavations, where possible use only free-draining materials. If overburden is used for backfill, ensure a free-draining area (drain) from the top to the bottom of the pit.

## 13.4.12 OVERVIEW OF OPEN PITS

### 13.4.12.1 F160 PIT

The F160 Pit design is based on:

- / Slopes in clay: 3H:1V (18.4°) to 3.5H:1V (15.9°).
- / Slopes in till: 2H:1V (26.6°).
- / Slopes in rock: Inter Ramp Angle (IRA) of 52.5°.
- / No underground excavations will be intercepted.
- / Mining the final phase currently.

A plan view of the ultimate F160 Pit is presented in Figure 13-7.

209  
209

Figure STYLEREF 1 \s 13-. Plan View of the F160 Pit Project

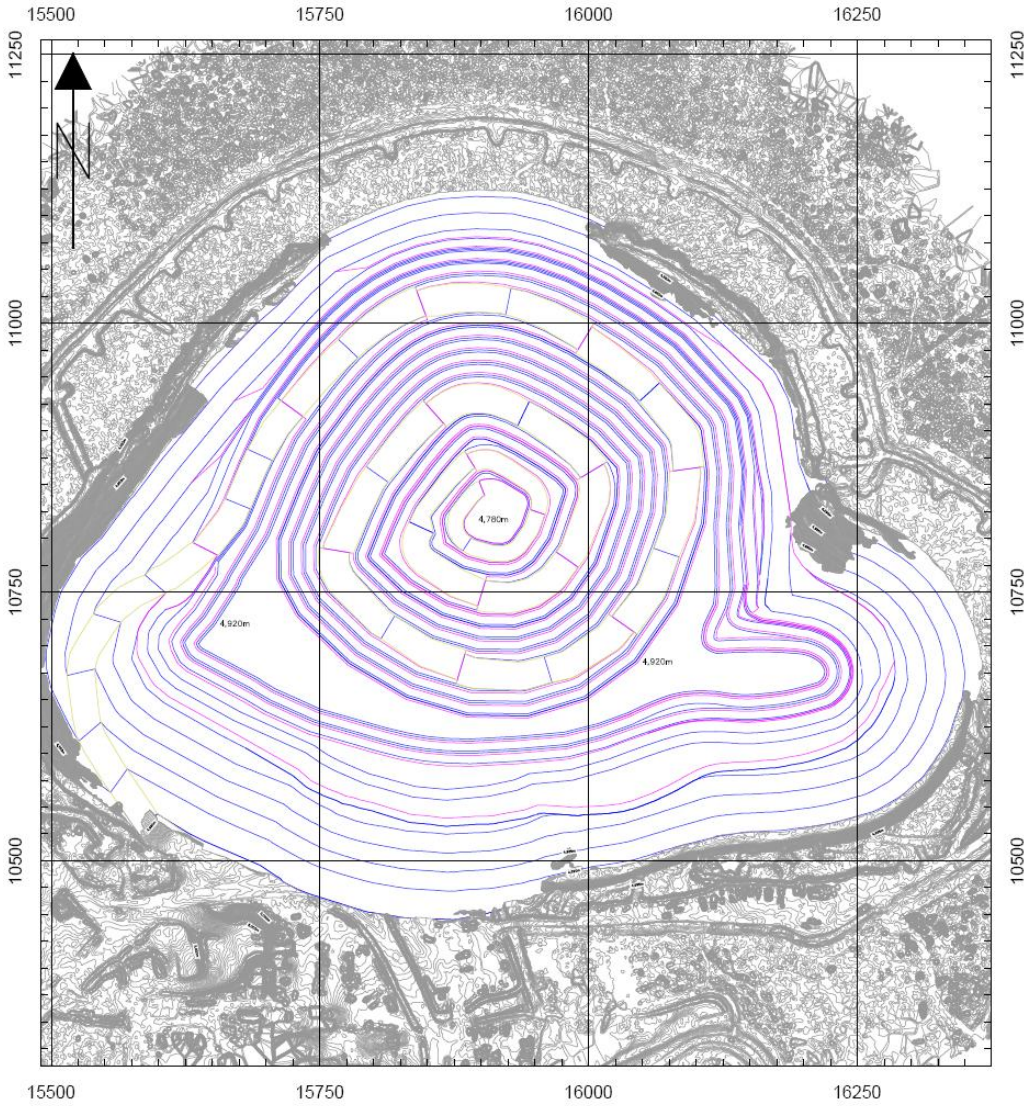

		F160 Ultimate Pit Map	
			Date: 12 December 2023 Scale: As Shown Coordinate System: Local Mine Grid - Meters
RESPEC Reno Office 775.856.5700		CASA BERARDI MINE QUEBEC CANADA	

The F160 Pit is planned for mining over the period from 2024 to 2026 and includes a total estimated 3.8Mt of ore.

210  
210

### 13.4.12.2 F134 PIT

The F134 Pit design is based on:

- / Slopes in clay: 3H:1V (18.4°).
- / Slopes in till: 2H:1V (26.6°).
- / Slopes in rock: IRA of 52.5°.
- / No underground excavations will be intercepted.
- / Mining to be carried out in a single phase.

A plan view of the ultimate F134 Pit is presented in Figure 13-8.

**Figure STYLEREF 1 \s 13-. Plan View of the F134 Pit (Ultimate Pit Shell)**

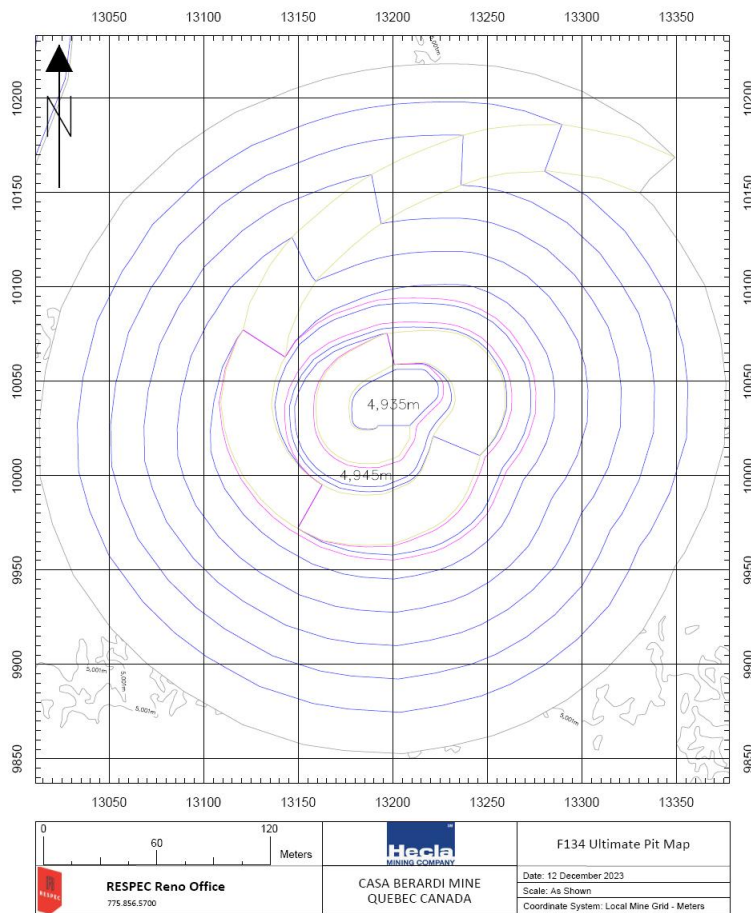

The F134 Pit is planned to be mined in 2037 and contained approximately 90kt of ore.

### 13.4.12.3 WMCP PIT

The WMCP Pit design is based on:

- / Slopes in clay: 3H:1V (18.4°).
- / Slopes in till: 2H:1V (26.6°).
- / Slopes in rock: IRA of 52.5°.
- / Underground excavations, including the main ramp, will be intercepted in the east and north walls.
- / Geotechnical considerations: Casa Berardi and Auxiliary Faults will intersect the final west and north-east wall.
- / Stripping of this pit is planned to occur beginning in 2030.

The plan view of the ultimate WMCP Pit is presented in Figure 13-9.

212  
212

Figure STYLEREF 1 \s 13-. Plan View of the WMCP Pit Project (Ultimate Pit Shell)

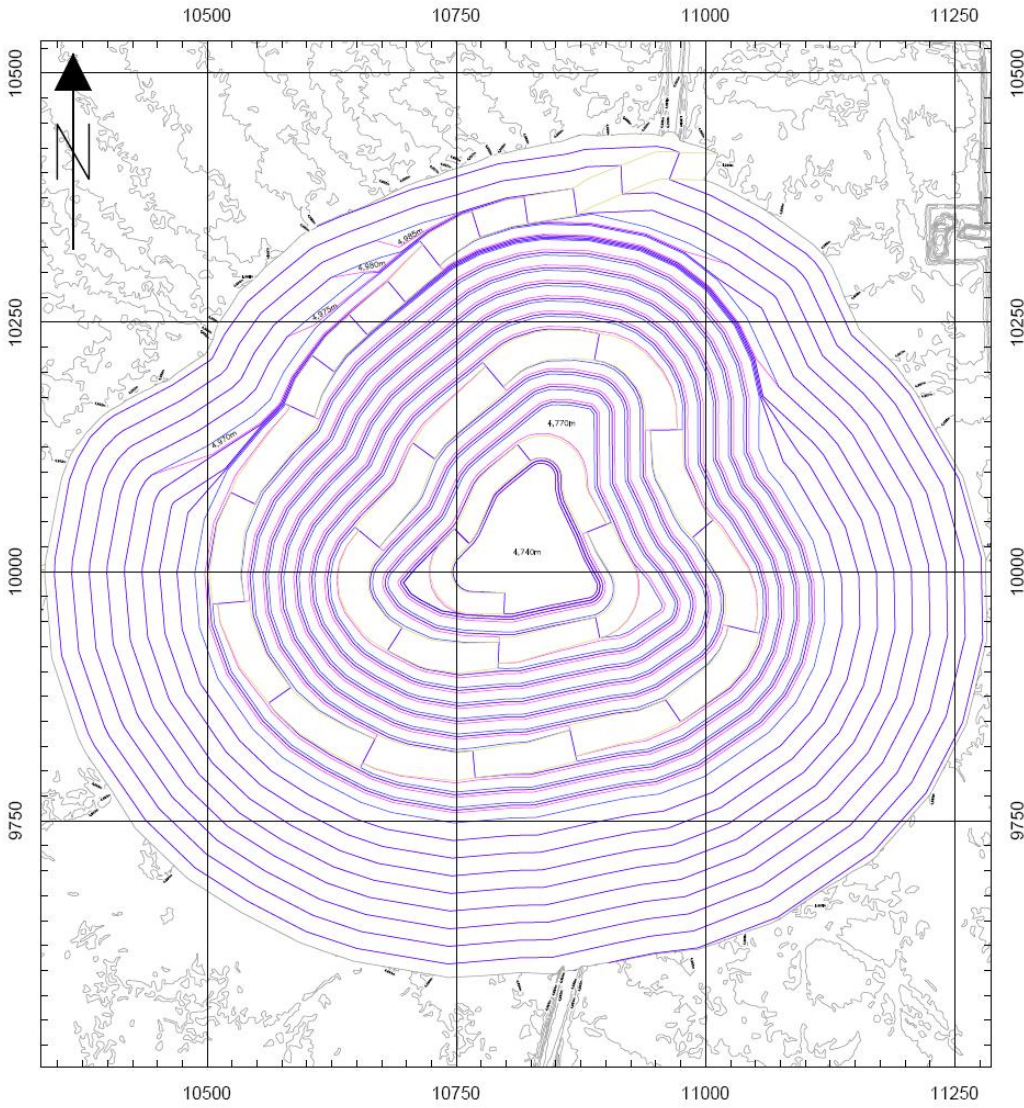

		WMCP Ultimate Pit Map
 <b>RESPEC Reno Office</b> 775.856.5700	CASA BERARDI MINE QUEBEC CANADA	Date: 12 December 2023 Scale: As Shown Coordinate System: Local Mine Grid - Meters

213  
213

The WMCP Pit is planned to be mined in the final LOM years. Overburden stripping will commence in 2031 whereas ore mining will occur from 2030 until 2037 for a total of 4.9Mt ore. During 2035 and 2036, WMCP will be the only pit in production.

#### 13.4.12.4 PRINCIPAL PIT

The Principal Pit design is based on:

- / Slopes in clay and sand: 3H:1V (18.4°).
- / Slopes in till: 2H:1V (26.6°).
- / Slopes in rock: IRA of 52.5°.
- / Underground excavations will be intercepted in the pit bottom.
- / Geotechnical considerations: excavation in proximity to an esker; inflow and contamination controls.

The plan view of the ultimate Principal Pit is presented in Figure 13-10.

214  
214

Figure STYLEREF 1 \s 13-. Plan View of the Principal Pit Project (Ultimate Pit Shell)

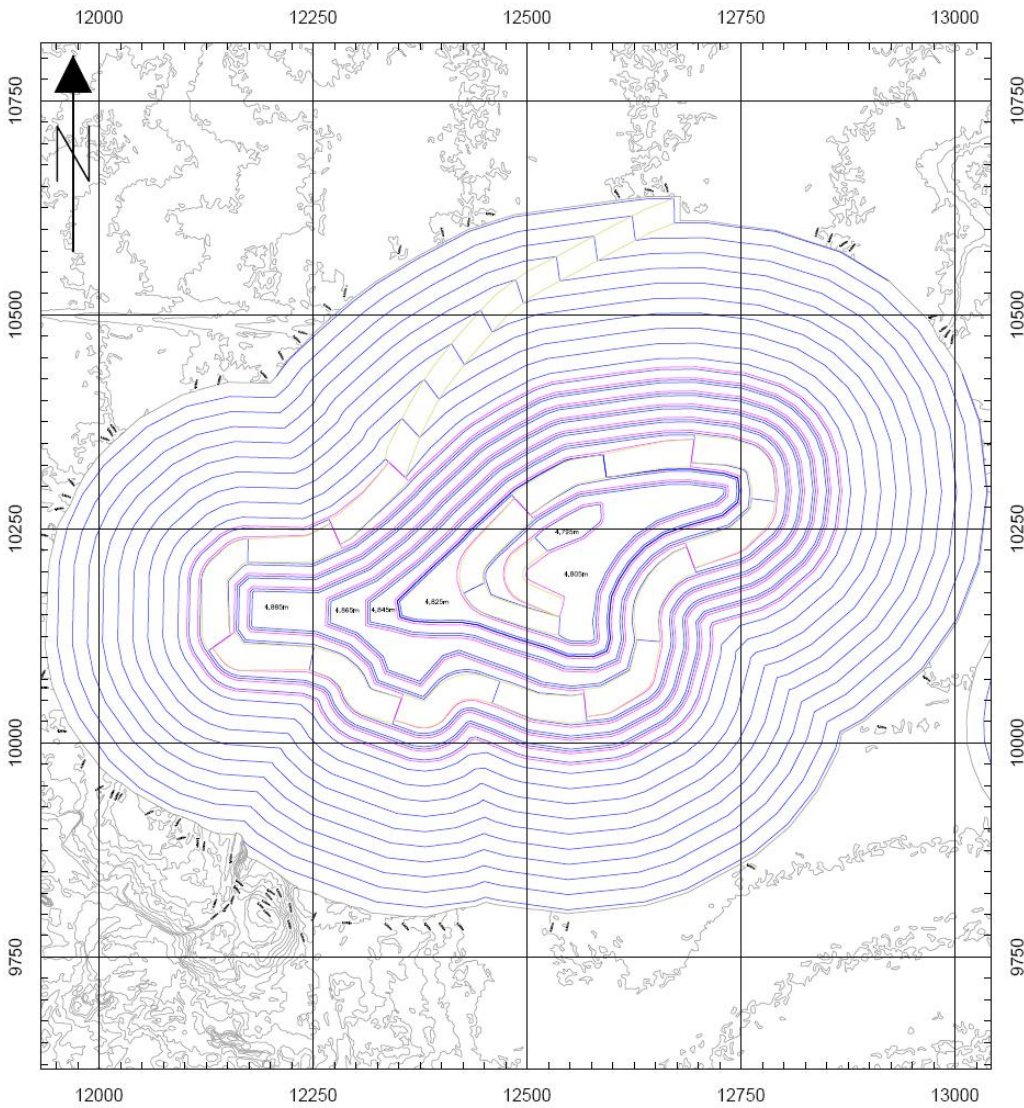

		<p>Principal Ultimate Pit Map</p>
 <p><b>RESPEC Reno Office</b> 775.856.5700</p>	<p>CASA BERARDI MINE QUEBEC CANADA</p>	<p>Date: 12 December 2023 Scale: As Shown Coordinate System: Local Mine Grid - Meters</p>

The Principal Pit stripping will begin in 2028, and ore production is planned to be mined over the period from 2030 to 2034 for a total of 5.4Mt.

215  
215

## 13.5 LONG-RANGE PLAN

Hecla's planning practice includes the development of an LRP. The LRP is based upon the Mineral Reserves plus a portion of the Mineral Resources. It is an internal Hecla document and is used as a guide for management's long-term production planning and expectations. The LRP includes operating cost requirements for the additional tonnes mined (i.e., Mineral Resources), as well as capital provisions for development, mine infrastructure and equipment for exploitation of the Mineral Reserve, and for conversion of the Mineral Resources that were included within the LRP. If mine production does not extend beyond the known Mineral Reserves, these costs would be less than the amount included in the LRP. The LRP is updated every year with the new information available.

## 13.6 LIFE OF MINE PLAN

The LOM plan for Casa Berardi closely follows the LRP with the Inferred Mineral Resources removed to ensure that only Mineral Reserves have been included for the economic analysis. The LOM plan includes 209kt grading 4.84g/t Au from underground and 14.2Mt grading 2.71 g/t Au from open pits, that will result in total recovered gold of 1.05Moz Au over the LOM.

Underground production is forecasted to average approximately 1,200tpd for 2024, while the open pits will average approximately 4000tpd over a 7-year period from 2030 to 2037 under the present operating plan, this excludes the years 2027 to 2029 as waste stripping years. In 2028 stripping on the Principal pit will begin, and mill material will be reached in 2030 and will level out at 1.6Mtpa in 2031 until the end of the mine life. Production will be provided from the open pits only starting in 2025 until 2037.

The processing plant will average a throughput of 3,500tpd over the LOM.

Silver production is estimated as 24% of the gold production based upon operating records and the silver revenue is included in the LOM plan financial analysis.

Table STYLEREF 1 \s 13-. LOM Production Forecast

Description	Units	Total	2024	2025	2026	2027	2028	2029	2030	2031	2032	2033	2034	2035	2036	2037
Days	Day		366	365	365	365	366	365	365	365	366	365	365	365	366	365
UG Production	000 t	209	209	-	-	-	-	-	-	-	-	-	-	-	-	-
OP Production	000 t	14,174	1,101	1,300	1,300	75	-	-	383	1,600	1,600	1,600	1,600	1,600	1,600	413
OP Waste & OB	000 t	219,455	22,795	7,500	18	-	9,752	19,345	29,811	29,838	30,049	30,171	26,910	6,009	3,171	4,086
Processing	000 t	14,383	1,310	1,300	1,300	75	-	-	383	1,600	1,600	1,600	1,600	1,600	1,600	413
Grade UG	g/t Au	4.84	4.84	-	-	-	-	-	-	-	-	-	-	-	-	-
Grade OP	g/t Au	2.72	1.74	1.79	1.86	1.86	-	-	3.14	3.22	3.21	2.94	3.04	3.12	2.88	2.54
Grade UG+OP	g/t Au	2.75	2.24	1.79	1.86	1.86	-	-	3.14	3.22	3.21	2.94	3.04	3.12	2.88	2.54
Gold Contained	000 oz Au	1,270	94	75	78	4	-	-	39	166	165	151	156	160	148	34
Mill Recovery	%	81.6%	89.5%	88.6%	88.8%	88.8%	0.0%	0.0%	83.1%	83.3%	83.3%	81.8%	77.6%	76.3%	75.7%	76.8%
Gold Production	000 oz Au	1,037	84	66	69	4	-	-	32	138	137	124	121	122	112	26

217  
217

## 14.0 PROCESSING AND RECOVERY METHODS

This section was contributed by SLR. The SLR QP has reviewed the information disclosed in this section and takes full responsibility for this information.

### 14.1 INTRODUCTION

Gold extraction from the mill feed will be performed in the current operating mill. Historical operation and performance data for the mill is summarized in Section 10.0 of this TRS. This information in combination with metallurgical test results is used to predict mill recovery performances. These performances are based on the current plant as of December 31, 2023. A description of the overall process plant is presented in the following subsections.

### 14.2 PROCESS DESCRIPTION

The Casa Berardi mill processes 3,730tpd, with future maximum production of 4,400tpd. Gold is recovered by Gravity Concentration and Carbon In Leach (CIL) processes. These processes were selected to optimize the recovery of free gold and reduce the preg-robbing effect of graphitic carbon on the cyanide leach process. Individual circuits within the process are detailed in subsequent sections of this chapter. Figure 14-1 below presents the flowsheet of the processing facility.

**Figure STYLEREF 1 \s 14-. Mill Flowsheet**

218  
218

RSI-M0206.22001

---

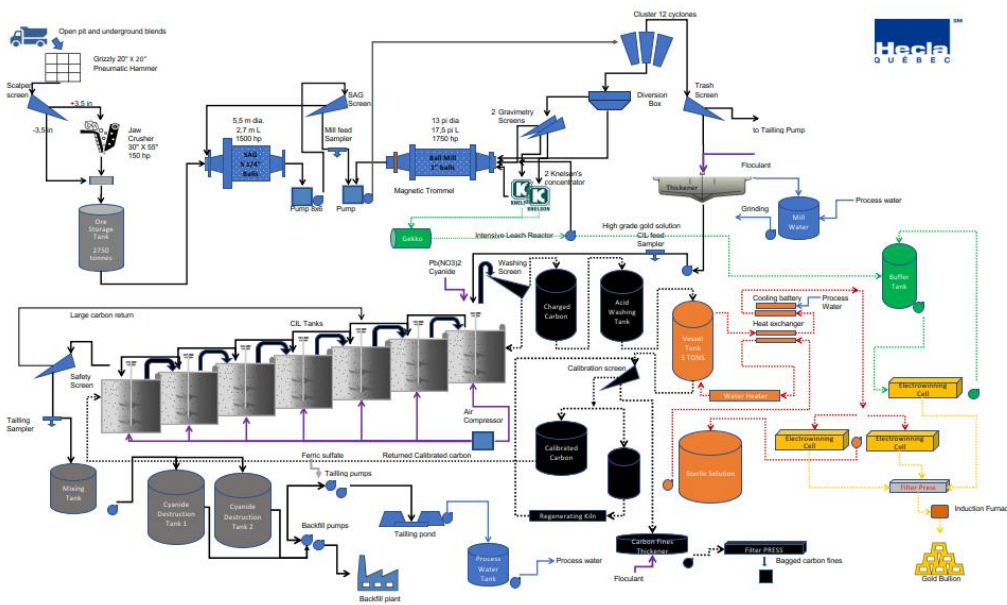

### 14.2.1 CRUSHING

Ore is hauled by truck from the West Mine headframe complex and the open pit to the crusher dump pocket, which is equipped with a static grizzly and a pneumatic hammer to break any oversize material. Ore passing the grizzly is screened again on the scalping screen. Oversize ore is fed to a jaw crusher and its discharge rejoins the scalping screen undersize. Crushed ore is stored in the ore storage bin.

### 14.2.2 GRINDING

Ore is conveyed from the storage bin to the SAG mill. The SAG mill feed conveyor is equipped with a scale to monitor and control the ore supply to the SAG mill, and a moisture analyzer to determine the moisture content of the mill feed and calculate dry feed tonnage. Dry quick lime is added onto the SAG mill feed chute for downstream pulp pH control, and mill water is added to the SAG mill feed chute to pulp the ore. The SAG mill operates in closed circuit with the SAG screen, discharging into the SAG screen pump box and pumping onto the SAG screen. SAG screen oversize material is returned to the SAG mill for further reduction and screen undersize flows to the cyclone pump box.

The ball mill operates in closed circuit with the cyclones cluster. The ball mill discharges to the cyclone feed pump box and the material is pumped to the cyclones. Since the last report, the classification circuit was modified from a two-stage cyclone system to a single-stage cyclone system to manage the grinding circuit mass flow more efficiently. The cyclone underflow is fed by gravity to a distribution box to divert flow to the gravity circuit or to the ball mill for further size reduction. The diversion valve is operated to supply maximum feed to the gravity circuit. The

219  
219

cyclones overflow reports to the production thickener, through a trash screen to remove debris. Trash screen oversize is sent to the tailings pump and the undersize feeds the production thickener.

#### 14.2.3 GRAVITY CIRCUIT

The gravity circuit feed, which is fed from the cyclone underflow, is split to feed two parallel gravity circuits. Each circuit consists of a vibrating screen and a gravity concentrator. The screen oversize from each circuit reports back to the ball mill and the screen undersize feeds a gravity concentrator. The concentrator's tailings discharges to the ball mill feed chute. The gravity concentrate flows to an intensive leach reactor (ILR) for leaching. To promote gold leaching and control the pH, hydrogen peroxide, cyanide, and caustic soda are added to the ILR unit from their respective tanks using dosing pumps. The high-grade pregnant gold solution from the ILR unit is pumped to the electrowinning buffer tank and the tailings report to the ball mill feed chute.

#### 14.2.4 CIL CIRCUIT

The production thickener is fed the cyclone overflow material after passing through the trash screen. Process water recycled from the tailings pond is added to the thickener feed well. The thickener overflow feeds the mill water tank for use in the process and the thickener underflow is pumped to the first CIL tank. CIL feed is sampled on the production thickener underflow stream. A CIL circuit is used to recover gold instead of a carbon-in-pulp circuit to hinder preg-robbing due to graphite in the ore and to maximize gold recovery by placing the gold in solution in contact with activated carbon immediately. The circuit comprises seven CIL tanks in series.

To promote gold leaching, a cyanide solution and lead nitrate is added to the #1 CIL tank. Compressed air is added to each CIL tank. Gold is leached from the ore and adsorbed onto activated carbon. Carbon is added in the #7 CIL tank and is pumped in counter-current fashion from the #7 CIL tank to the #1 CIL tank. Screens at the discharge of each CIL tank prevent carbon from overflowing from tank to tank with the pulp. The #7 CIL tank overflows onto a safety screen to recover any fugitive carbon. Recovered carbon is bagged to return in the circuit or sent to a refinery to recover the gold. The safety screen undersize is sampled and reports to the mixing tank. Fine quicklime is added to the mixing tank to prepare for cyanide destruction. Residual pulp from the CIL mixing tank is pumped to the two cyanide destruction tanks in series with sulfur dioxide and copper sulfate in the first tank. Compressed air is added to both tanks to destroy residual cyanide with agitation. After cyanide destruction, the treated pulp is pumped to the paste backfill plant or the tailings pond. Ferric sulfate is also added to the tailings material to reduce arsenic content in the solution.

#### 14.2.5 CARBON CIRCUIT

The carbon, elution, and electrowinning circuits operate in batches unlike the CIL continuous process. Loaded carbon is pumped from the #1 CIL tank onto a washing screen. Loaded carbon from the washing screen falls into the loaded carbon tank while the pulp and residual cyanide solution return to the #1 CIL tank or #2 CIL tank. When carbon collection is completed, loaded carbon is transferred to the elution vessel. After elution, eluted carbon is transferred to the acid washing tank where hydrochloric acid is added and carbon is soaked for two hours to remove inorganic contaminants. When the acid wash is completed, the unloaded carbon is rinsed with process water to return to a neutral pH before being screened and sent either to the calibrated carbon tank or the regenerating kiln. Calibration screen undersize is sent to the carbon fines thickener. Carbon fines are recovered at the underflow, filtered using a filter press, and bagged. At the regenerating kiln, the carbon is heated to remove organic

220  
220

contaminants. The kiln discharges in a quench tank and carbon is pumped back onto the calibration screen. Calibrated carbon is pumped back into the #7 CIL tank from the calibrated carbon tank. Fresh activated carbon is also added to the CIL circuit using the calibration screen after being processed via an attrition tank. Carbon moves in the circuit using a water eductor system.

#### 14.2.6 ELUTION AND ELECTROWINNING CIRCUITS

The elution circuit uses the Zadra process, where caustic soda is added to process water in the barren solution tank to prepare for elution. The barren solution is pumped through a heat exchanger and a water heater before arriving at the bottom of the elution vessel. Under the correct pressure and temperature conditions in the elution vessel, gold desorbs from the loaded carbon and dissolves in the elution solution. The pregnant solution flows from the top of the elution vessel through the heat exchanger and cooling battery toward the electrowinning cells. The heat exchanger recovers heat from the pregnant solution to warm up the barren solution. The cooling battery completes the pregnant solution cooling to a safe temperature and pressure for electrowinning using process water at an ambient temperature.

Two electrowinning cells recover dissolved gold from the pregnant solution by deposition on its cathode plates to form a gold sludge. Barren elution solution is pumped from the electrowinning cells to the barren solution tank. During an elution cycle, elution solution flows continuously through the circuit. A third electrowinning cell, in loop with the ILR buffer tank, is dedicated to the ILR gold solution. When an elution cycle is over, gold sludge is recovered from the electrowinning cells, filtered, and dried before being smelted in the induction furnace and poured into gold doré at the gold room.

#### 14.2.7 MAJOR EQUIPMENT LIST

Table 14-1 presents a list of major equipment and its characteristics.

**Table 14-1. Major Equipment List**

Equipment	Characteristics
	Crushing
Grizzly Screen	Static, 5m x 4.2m with 571.5mm x 489mm opening
Rock Breaker	Hydraulic hammer
Scalping Screen	Vibrating, 1.5m x 2m with 89mm opening and 11.2kW motor
Jaw Crusher	762mm x 1400mm opening with 150hp motor
Ore Storage Bin	14m diameter, 19m high with 3,000t capacity
	Grinding
SAG Mill	5.5m diameter x 2.7m EGL with 1,130kW motor
SAG Screen	Vibrating, 1.8m x 2.9m with 5mm x 16mm opening and 2 x 3.7kW motors
Ball Mill	4.0m diameter x 5.3m length with 1,325kW motor

221  
221

Equipment	Characteristics
Cyclones	250mm diameter Metso, ten operating, two standby units
Trash Screen	Vibrating, 1.15m x 2.5m with 700 micron opening and 1.8kW motor
Gravity Circuit	
Gravity screens	Vibrating, 1.8m x 4.3m with 3mm x 20mm opening and 2 x 3hp motors
Gravity Concentrators	Two 762mm diameter Knelson concentrators
Intensive Leach Reactor	2.27m larger x 4.4m length Gekko Leach unit with tanks
Gravity Electrowinning cell	3.26m <sup>3</sup> cells with eight cathodes
CIL	
Production Thickener	34m diameter with high rate type feedwell
CIL Tanks	Seven 700m <sup>3</sup> capacity tanks
CIL Agitators	One 3.45m diameter double impeller with 37kW motor for each tank
CIL Screens	Two Westech 4m <sup>2</sup> and three Westech 3.8m <sup>2</sup> screens
Safety Screen	Vibrating, 1.2m X 2.4m with 20 mesh opening and 3.7kW motor
Tailings Mixing Tank	One 27m <sup>3</sup> capacity tank with 30kW agitator
Cyanide Destruction Tank	Two 322m <sup>3</sup> capacity tanks with 149kW agitator
Carbon Circuit	
Loaded Carbon Washing Screen	Vibrating, 1.2m x 2.4m with 20 mesh opening and 3.7kW motor
Loaded Carbon Tank	One 5.5t of carbon capacity
Acid Washing Tank	One 5.5t of carbon capacity
Carbon Calibration Screen	Vibrating, 1.2m x 2.4m with 16 mesh opening and 3.7kW motor
Carbon Calibrated Carbon Tank	One 15.8m <sup>3</sup> capacity tank
Regenerating Kiln	0.76m diameter, 7.3m length with 350kW of heating capacity
Carbon Fines Thickener	One 5m diameter with high-rate type feedwell
Carbon Fines Filter Press	One 23.5m <sup>2</sup> of filtration with 20 chambers
Elution	
Elution Vessel	One 1.68m diameter tank 5.5t carbon capacity
Water Heater	870kW capacity water heater
Barren Solution Tank	One 153m <sup>3</sup> capacity tank
Electrowinning Cells	Two 4.53m <sup>3</sup> cells with 12 cathodes each
Refinery	
Filter Press	One 24.8m <sup>2</sup> of filtration with 21 chambers

Equipment	Characteristics
Induction Furnace	One 750lbs capacity with 125kW

### 14.3 ENERGY, WATER, AND PROCESS MATERIALS REQUIREMENTS

Power requirements for the processing facilities are not anticipated to change significantly in the foreseeable future from the current power requirements (approximately 7MW).

Make-up water is supplied from the process water pond. Water consumption is not expected to change significantly from the recent historical annual water usage (2.3 million m<sup>3</sup>) and no supply concerns have been noted.

Key reagents used in the process include quick lime, cyanide, caustic soda, ferric sulfate, fine quick lime, copper sulfate, hydrochloric acid, and sulfur dioxide. Reagent consumption is presented in Table 14-2.

223  
223

**Table STYLEREF 1 \s 14-. Reagent Consumption 2023**

<b>Reagent</b>	<b>kg/t</b>
Hydrochloric acid	0.027
Caustic soda	0.275
Copper sulfate	0.176
Iron sulfate	1.134
Sulfur dioxide	0.843
Lead nitrate	0.128
Carbon	0.039
Sodium cyanide	0.504
Fine Limestone	0.711
Coarse Limestone	0.772
Hydrogen peroxide	0.029
Flocculant	0.004

## 14.4 PERSONNEL

The total processing plant personnel required for 2024 operations is 91 Hecla employees, with an additional 11 mill maintenance contractors required. Required personnel will fluctuate throughout the remainder of the mine life, depending on operations needs but will generally remain at approximately 84 employees and 11 mill maintenance contractors, with the exception of 2028 through 2030, during a planned mill shutdown and expansion.

224  
224

## 15.0 INFRASTRUCTURE

Casa Berardi is a producing mine and has developed infrastructure to support the onsite operations. There are well-maintained gravel and paved roads that provide access to the property and there is a network of roads on the site to service the mine areas and various facilities. Water sources have been developed for the operation of the onsite surface and underground mines and power is supplied from the grid.

### 15.1 ROADS AND LOGISTICS

A 38km all season gravel road that provides access to the Casa Berardi Property branches off from the paved road (provincial roads 101 and 111) linking La Sarre and the Selbaie Mine approximately 21km north of the village of Villebois.

On the Property, a gravel road links the East and West mine areas and exploration roads provide access to the rest of the Property to the east and west of the active parts of the Property (Figure 15-1). A production road and a staff road are in use as discussed in Section 4.5. Roads will be relocated as required for the development of Principal, WMCP, and F134 pits and are presented in Figure 15-1.

A 5-kilometer track drift joins the East and West mine areas and will provide access to the planned Principal Mine at the 280m level. After the East Mine was closed, a bulkhead was constructed on the track drift to control water flow to the West Mine. There is currently no additional surface infrastructure related to the planned Principal Mine area which is located between the East and West Mines.

225  
225

**Figure STYLEREF 1 \s 15-. Surface Infrastructure (Current and Preliminary)**

226  
226

RSI-M0206.22001

---

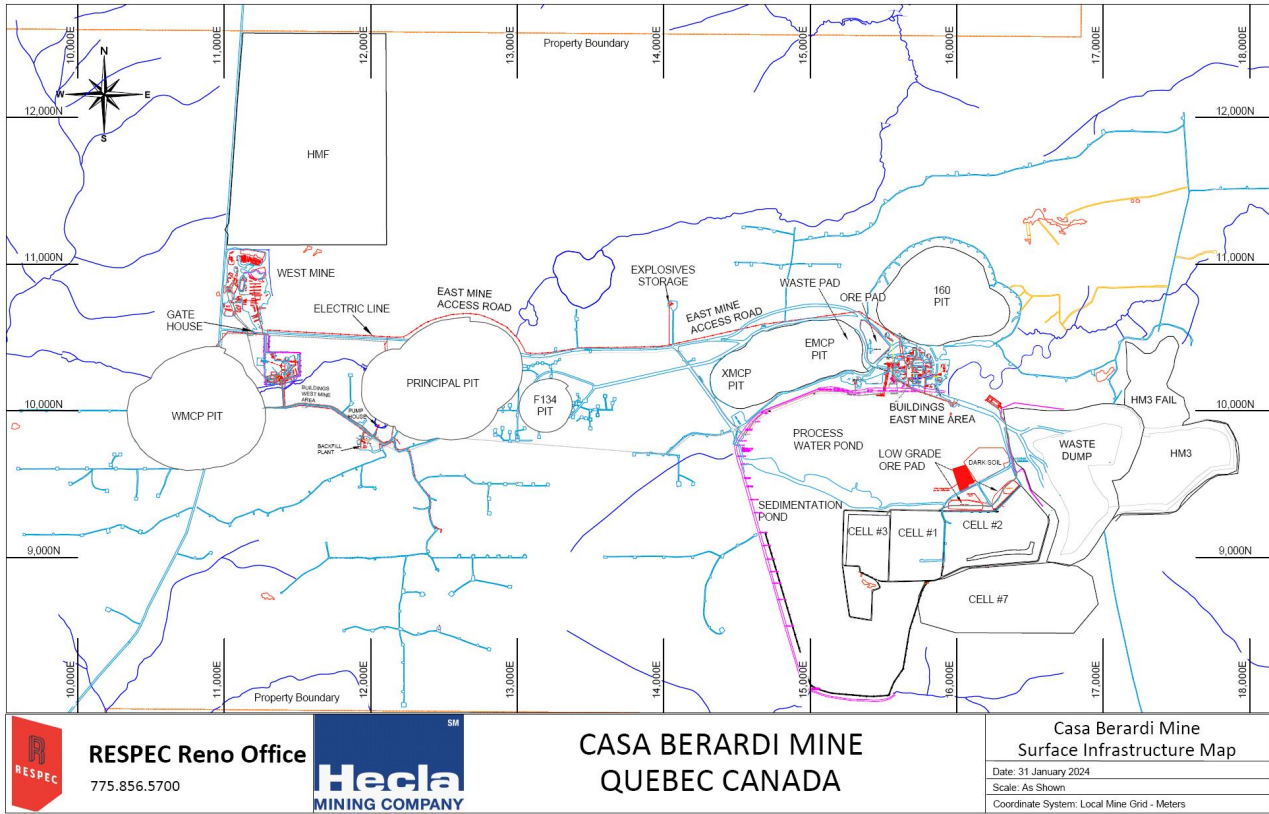

227  
227

RSI-M0206.22001

### Mine Layout

Tailings and waste rock management, waste generated at the site, water supply and usage, power supply, and fuel are discussed in Sections 15.1.1 through 15.1.8. The current and preliminary major infrastructure areas are presented in Figure 15-1 through Figure 15-3.

The active mining portion of the Casa Berardi Property is in the central part of the overall land package Figure 15-2 portion of the property is divided into the East and West mine areas which include most of the surface infrastructure, open pits, and underground mines.

Existing surface and underground infrastructure at the East Mine area (Figure 15-2) include the following:

- / A nominal 3,730tpd mill, with the ability to process 4,400tpd.
- / F160, EMCP, and XMCP open pits.
- / TSF with five tailings cells, a polishing pond, a sedimentation pond, and a process water pond.
- / Two-story administrative building with offices, warehouse, dry, laboratory, two heavy equipment maintenance garages, millwright shop, and electrical shop (main building, East Mine are in Figure 15-2).
- / Two core shacks.
- / Water pumping station.
- / Hoistroom, a headframe, and a 381m deep shaft (with no hoist).
- / Mine access decline and a series of ramp-connected levels.
- / Three petrol tanks with pump gas and fuel.
- / One mineralized rock stockpile.
- / One waste and till-clay pile.

**Figure STYLEREF 1 \s 15-. East Mine Surface Infrastructure**

229  
229

RSI-M0206.22001

---

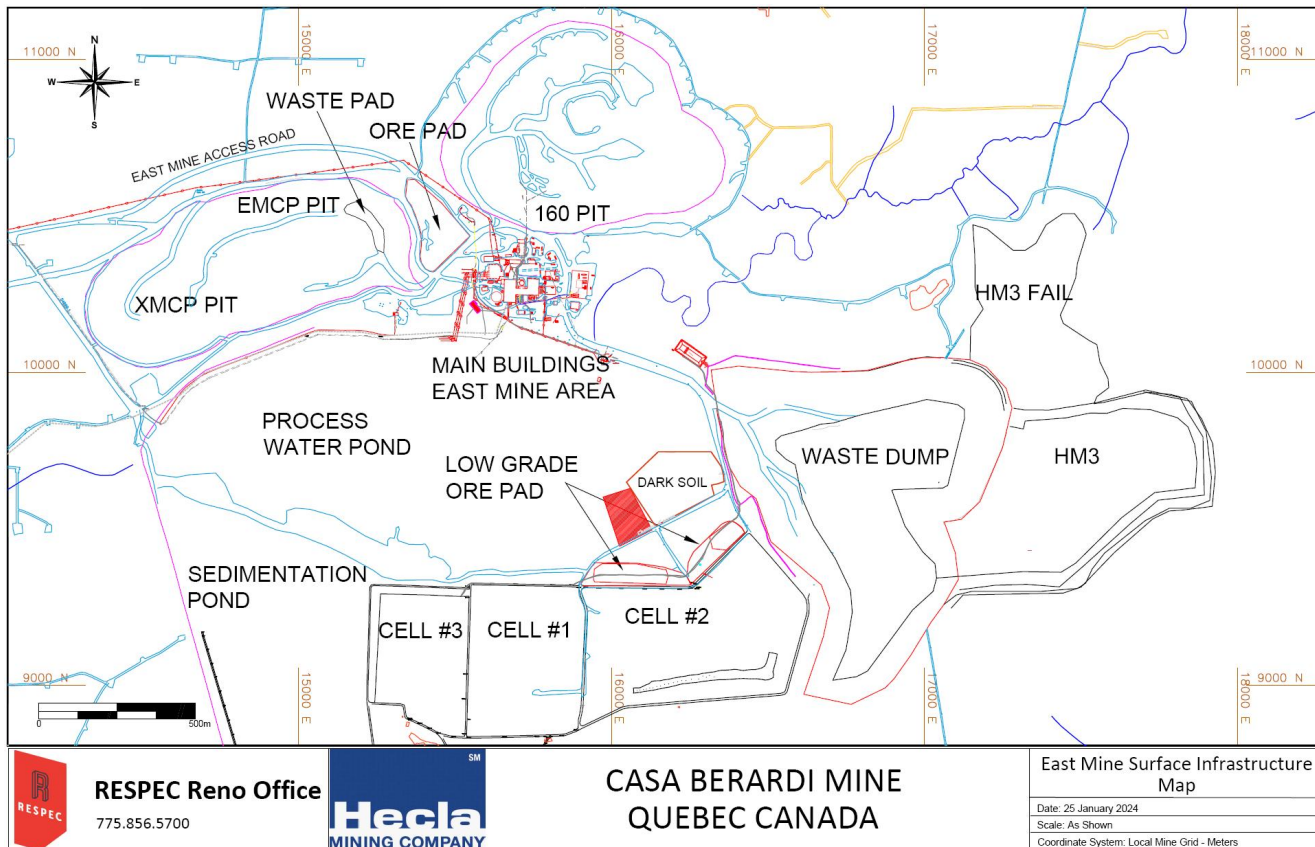

**RESPEC Reno Office**  
775.856.5700



**CASA BERARDI MINE**  
**QUEBEC CANADA**

East Mine Surface Infrastructure  
Map

Date: 25 January 2024  
Scale: As Shown  
Coordinate System: Local Mine Grid - Meters

230  
230

RSI-M0206.22001



Existing surface and underground infrastructure at the West Mine (Figure 15-3) include the following:

- / Backfill plant, including a compressor room and a ventilation raise intake.
- / Settling ponds.
- / Pumping station.
- / A 380m<sup>2</sup> garage.
- / Two dry houses with offices.
- / Emergency building for mine rescue and infirmary.
- / Warehouse.
- / Core storage area.
- / Gatehouse.
- / Mine access decline providing access to the West Mine and Principal areas.
- / Hoistroom, headframe, and mine shaft to the 1,080-meter level.
- / A 140tph paste backfill plant and a cement plant with tailings feed line from the mill and distribution holes to the underground.
- / Mine ventilation fans and mine air heater with ventilation raise to the mine workings.
- / One WRF and one ore rock pile.

**Figure STYLEREF 1 \s 15-. West Mine Surface Infrastructure**

233  
233

RSI-M0206.22001

---

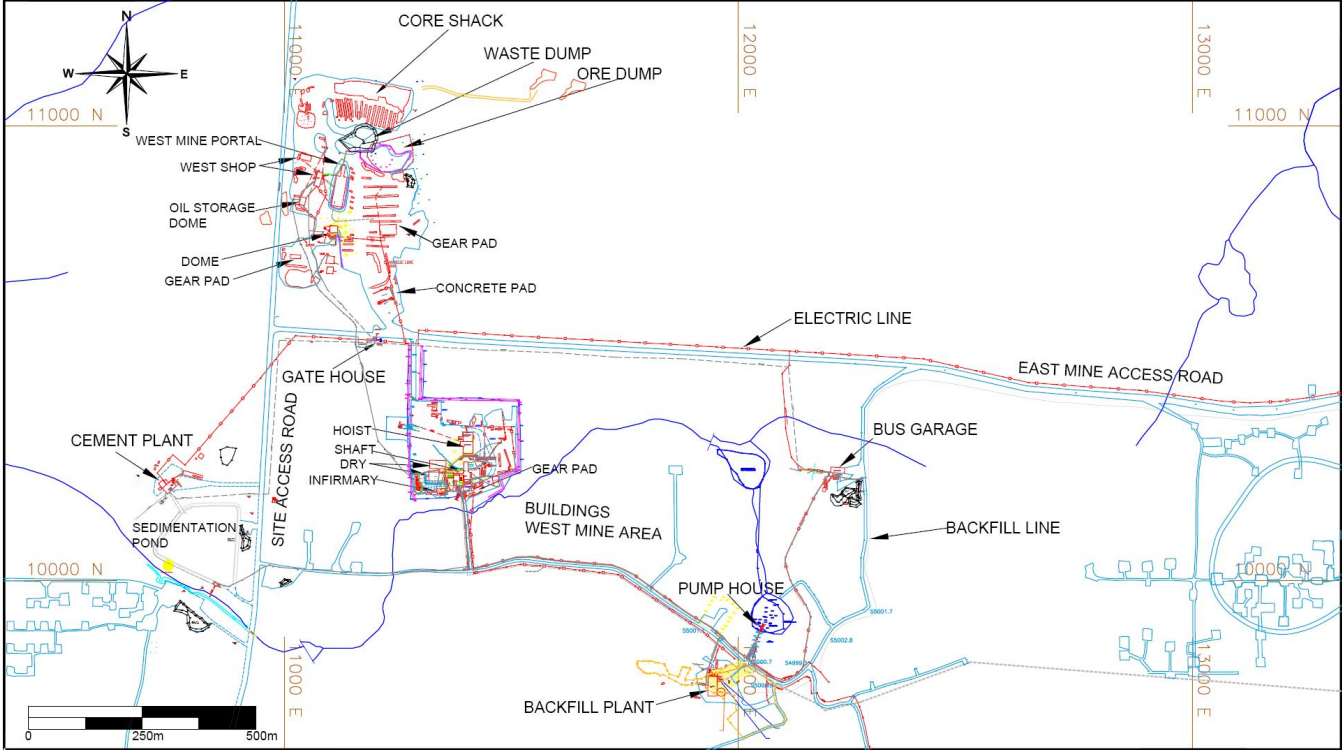

**RESPEC**  
**RESPEC Reno Office**  
 775.856.5700

**Hecla**  
 MINING COMPANY

**CASA BERARDI MINE**  
**QUEBEC CANADA**

**West Mine Surface Infrastructure**  
**Map**

Date: 25 January 2024  
 Scale: As Shown  
 Coordinate System: Local Mine Grid - Meters

234  
 234

### 15.1.1 TAILINGS MANAGEMENT AND FACILITIES

The site includes an existing tailings storage facility (TSF) with five tailings cells (Cells #1 through #4 and Cell #7), a polishing pond, a sedimentation pond for settling iron arsenate precipitates, and a process water pond (Figure 15-4).

Figure STYLEREF 1 \s 15-. Surface Plan Tailings and Waste Rock Facilities

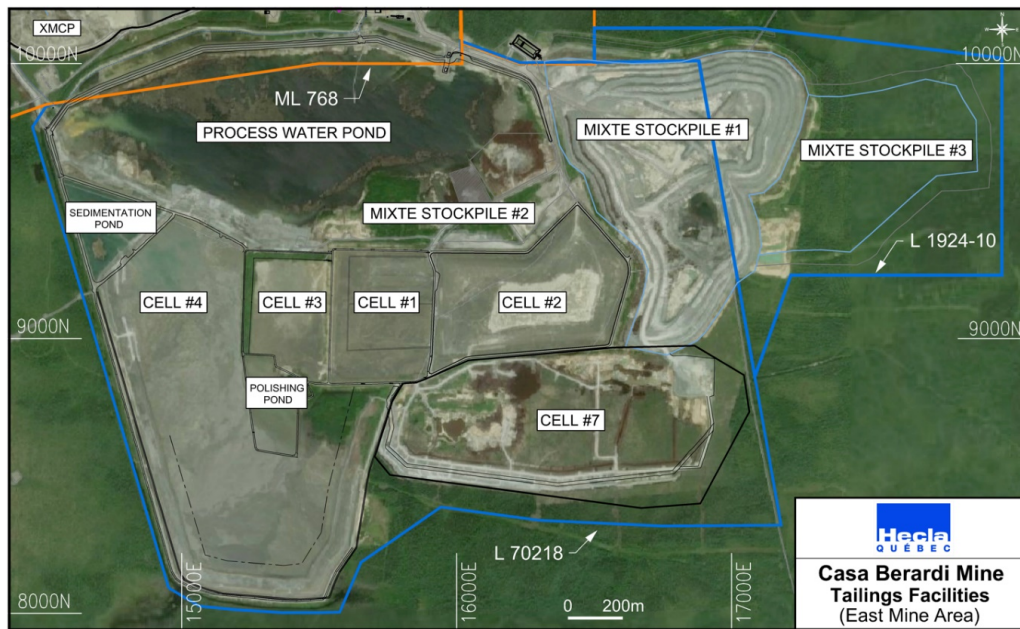

In 2022, approximately 9% of the mine tailings were used in the mine backfill and approximately 8% were used for mine backfill in 2023. This cycle of mine tailings utilization will continue until closure of the underground mine in 2024. Tailings that are not used for mine backfill are placed on the surface at the TSF. Permits are in place for mine water management and operation of the TSF. The monitoring system associated with the TSF includes surface and groundwater monitoring, water level monitoring, geochemical and geotechnical monitoring, and regular inspections. An operation, maintenance, and surveillance (OMS) manual has been developed for the TSF.

Tailings deposition is currently ongoing in Cell #7. Cells #1 through #4 are no longer used for deposition, being at their design capacity and Cells #1 through #3 are currently in the process of progressive reclamation.

Cell #7 was constructed in 2019 and has undergone additional lifts in 2021 through 2023 to accommodate mill tailing disposal needs. Additional lifts will be constructed as needed to accommodate production.

235  
235

The F160 Pit will become a tailings disposal site after the completion of Cell #7. Studies are underway to develop the F160 for this purpose. Given the permitting history at Casa Berardi and the high standards of practice followed by Hecla, the company believes that obtaining necessary permits for expanding the required TSFs will not present any issues.

### 15.1.2 WASTE ROCK MANAGEMENT AND STOCKPILES

Casa Berardi is permitted to store waste rock on the surface. The waste rock has been regularly monitored (sampled and analyzed) for its acid-generating potential since 2008. There has been no indication that it is acid generating.

### 15.1.3 Waste rock and overburden

Overburden (till, clay, and organics) from the F160 Pit are currently disposed of in the mined out EMCP pit. A new waste disposal facility is expected to be constructed for storage of waste materials from the planned Principal, WMCP, and F134 pits, as shown in The active mining portion of the Casa Berardi Property is in the central part of the overall land package Figure 15-2 portion of the property is divided into the East and West mine areas which include most of the surface infrastructure, open pits, and underground mines.

Existing surface and underground infrastructure at the East Mine area (Figure 15-2) include the following:

- / A nominal 3,730tpd mill, with the ability to process 4,400tpd.
- / F160, EMCP, and XMCP open pits.
- / TSF with five tailings cells, a polishing pond, a sedimentation pond, and a process water pond.
- / Two-story administrative building with offices, warehouse, dry, laboratory, two heavy equipment maintenance garages, millwright shop, and electrical shop (main building, East Mine are in Figure 15-2).
- / Two core shacks.
- / Water pumping station.
- / Hoistroom, a headframe, and a 381m deep shaft (with no hoist).
- / Mine access decline and a series of ramp-connected levels.
- / Three petrol tanks with pump gas and fuel.
- / One mineralized rock stockpile.
- / One waste and till-clay pile.

Figure 15-2 (mixed stockpiles). The new waste disposal facility will require additional permits, which Hecla believes will not present a material issue.

#### 15.1.4 OTHER WASTES

All other waste (hazardous materials) produced at the site are disposed of in accordance with regulatory requirements and legislation. No modifications to the current mine practices will be necessary for future operations.

#### 15.1.5 WATER SUPPLY

Fresh water supply is from groundwater production wells and groundwater collected in a series of underground seep collection areas.

Water management (mine, surface, and tailings) and effluent treatment are discussed in Section 17.0.

#### 15.1.6 WATER USE

Groundwater is utilized for underground operations at the West mine area, in the paste backfill plant, and the cement plant. It is also used as potable water at the plant site facilities.

The primary source of water for plant operations is the reclaim water from the process water pond (recycled water). Fresh water has limited use at the plant.

#### 15.1.7 POWER AND ELECTRICAL

Electrical power is supplied to the site by a 55km, 120kV power line from the town of Normétal. The electrical line will be relocated as necessary with the development of future pits.

#### 15.1.8 FUEL

Three fuel tanks are located near the EMCP Pit as discussed in Section 15.1.3. Fuel tank locations will be reviewed as engineering design progresses for the planned Principal, WMCP, and F134 pits.

## 16.0 MARKET STUDIES

Casa Berardi is in operation and has been operating steadily since 2006 producing gold and silver in doré bars.

### 16.1 MARKETS

#### 16.1.1 OVERVIEW

Gold supply is approximately 165 million ounces, with mine production contributing 75% of gold supply and recycling accounting for the remaining 25%. In terms of gold demand, jewelry fabrication accounts for approximately 55% of total demand while Investment in physical bars, coins and Exchange Traded Funds is at 25% of overall demand. Gold's use in technology applications was around 11 million ounces, or 8% of total demand in 2021, according to the World Gold Council. Accommodative fiscal and monetary policies globally due to COVID-19 lent support to investment demand for gold in 2020 as gold prices reached record levels in 2020.

Silver demand is primarily composed of industrial demand, which accounts for 50% of total silver demand of 1 billion ounces. Investment demand (physical and exchange traded products) and jewelry and silverware account for 25% share each, respectively. Silver has the highest electrical conductivity of all metals and this property positions silver as a unique metal for a multitude of uses in electronic circuitry in automotive and electronics. Silver's use in photovoltaic cells has also seen a rapid expansion in the past five years and is expected to be one of the key growth areas in green energy.

#### 16.1.2 COMMODITY PRICE PROJECTIONS

Metal prices used in the estimation of Mineral Resources and Mineral Reserves is determined by Hecla's corporate office in Coeur d'Alene, Idaho, USA. Casa Berardi Mineral Reserves are estimated using a price of US\$1,850/oz Au for the underground and US\$1,650/oz Au for the open pit, while gold Mineral Resources are estimated using a price of US\$1,750/oz Au. Due to the limited life of mine for the underground Hecla utilized a short-term metal price to state reserves.

Table 16-1 shows the realized metal prices Hecla has received for sales of its products.

Table STYLEREF 1 \s 16-. Hecla Historical Average Realized Metal Prices

Metal Prices	2021	2022	2023	3-Year Avg.
Silver (\$/oz)	25.24	21.48	22.97	23.23
Gold (\$/oz)	1,796	1,801	1,944	1,847

The economic analysis performed in the LOM plan assumes a constant gold price of US\$1,950/oz Au and US\$22.00/oz Ag based upon analysis of consensus metal price forecasts by financial institutions. Based on

238  
238

macroeconomic trends, RESPEC accepts the basis for using the higher metal prices for completing the economic analysis.

## 16.2 CONTRACTS

### 16.2.1 REFINING

Hecla currently has a refining agreement with Asahi Refining Canada (Asahi) whereby the refined gold and silver is refined and credited to Hecla's account at Asahi. The doré bars produced at Casa Berardi are refined at Asahi's facilities in Brampton, Ontario, Canada.

Gold and silver bullion is sold through commercial banks or metal traders via a sale contract at spot prices. Settlement of funds from bullion sales occurs two business days after the contract date.

The terms and conditions of the refining and bullion sales contracts are typical and consistent with standard industry practice and would be similar to contracts for the supply of gold elsewhere in North America.

### 16.2.2 OTHER CONTRACTS

Casa Berardi is in operation and has been operating steadily since 2006. There are numerous contracts in place for items including the operation of the F160 Pit, service contracts related to the operation, underground mine development contracts, and contracts for supplies. These are usual contracts for an operating mine.

## 17.0 ENVIRONMENTAL STUDIES, PERMITTING, AND PLANS, NEGOTIATIONS, OR AGREEMENTS WITH LOCAL INDIVIDUALS OR GROUPS

### 17.1 ENVIRONMENTAL CONSIDERATIONS

Casa Berardi is an operating mine, and the Property was formerly the subject of environmental baseline studies and reviews prior to the start of operations in 2006. Additional studies were carried out for the F160 Pit including a hydrogeology study in 2019, a bird and amphibian study in 2017, and a fish habitat water quality and sediment study in 2017.

The primary mine waste products produced at the site are tailings from the onsite mill, waste rock, and clay and tilt from stripping. Tailings and waste rock disposal are discussed in Sections 15.1.1 and 15.1.2 of this TRS.

Hecla is committed to operating in compliance with all regulations and standards of good practice for environmental, health, and safety. To uphold this commitment, Hecla has developed corporate policies for environmental and health and safety practices and has prepared a detailed management plan to facilitate the continuous improvement of its environment and health and safety performance. An Environmental Management System (EMS) is currently in place and audited periodically.

Hecla participates in the Towards Sustainable Mining (TSM) initiative of the Mining Association of Canada and Québec Mining Association. In 2016, the Québec Mining Association evaluated the sustainable mining development initiative at the Property. An action plan has been put in place for the eight protocols of the initiative, including tailings management, Indigenous Peoples and community outreach, biodiversity conservation management, climate change, water management, energy use and greenhouse gas (GHG) emissions management, health and safety, crisis management planning, and the prevention of child and forced labor. Since 2016, Hecla has continued to work on the implementation and improvement of management systems. RESPEC understands that an external audit was completed at the end of 2022, with the objective of improving performance while ensuring that primary mining risks are managed responsibly at the mine facilities.

The current LOM plan includes extraction of mineralized material from the active F160 Pit, planned mining of the preliminary Principal, WMCP, and F134 pits, backfilling of the EMCP Pit, and upgrades to the milling facilities. The preliminary designs for the Principal, WMCP, and F134 pits are flexible and allow for modifications to improve performance as needed. Almost all future mining activities will be from surface operations with the remaining underground mining activities ending in 2024. The mine and facilities designs meet current standards of practice for the mining industry and continued implementation of the environmental and health and safety procedures ensures that the Casa Berardi Mine is prepared to meet future challenges.

240  
240

## 17.2 WATER MANAGEMENT AND EFFLUENT TREATMENT

### 17.2.1 WATER MANAGEMENT

Casa Berardi has a positive water balance and discharges surplus water as effluent into Kaakakosig Creek. Site water is managed and handled in the TSF and then released to the environment via the PROCESS WATER POND (PWP).

Figure 17-1 presents a simplified illustration of the mine site water management system.

241  
241

RSI-M0206.22001

---

**Figure STYLeref 1 \s 17-. Water Management Flow Sheet**

242  
242

RSI-M0206.22001

---

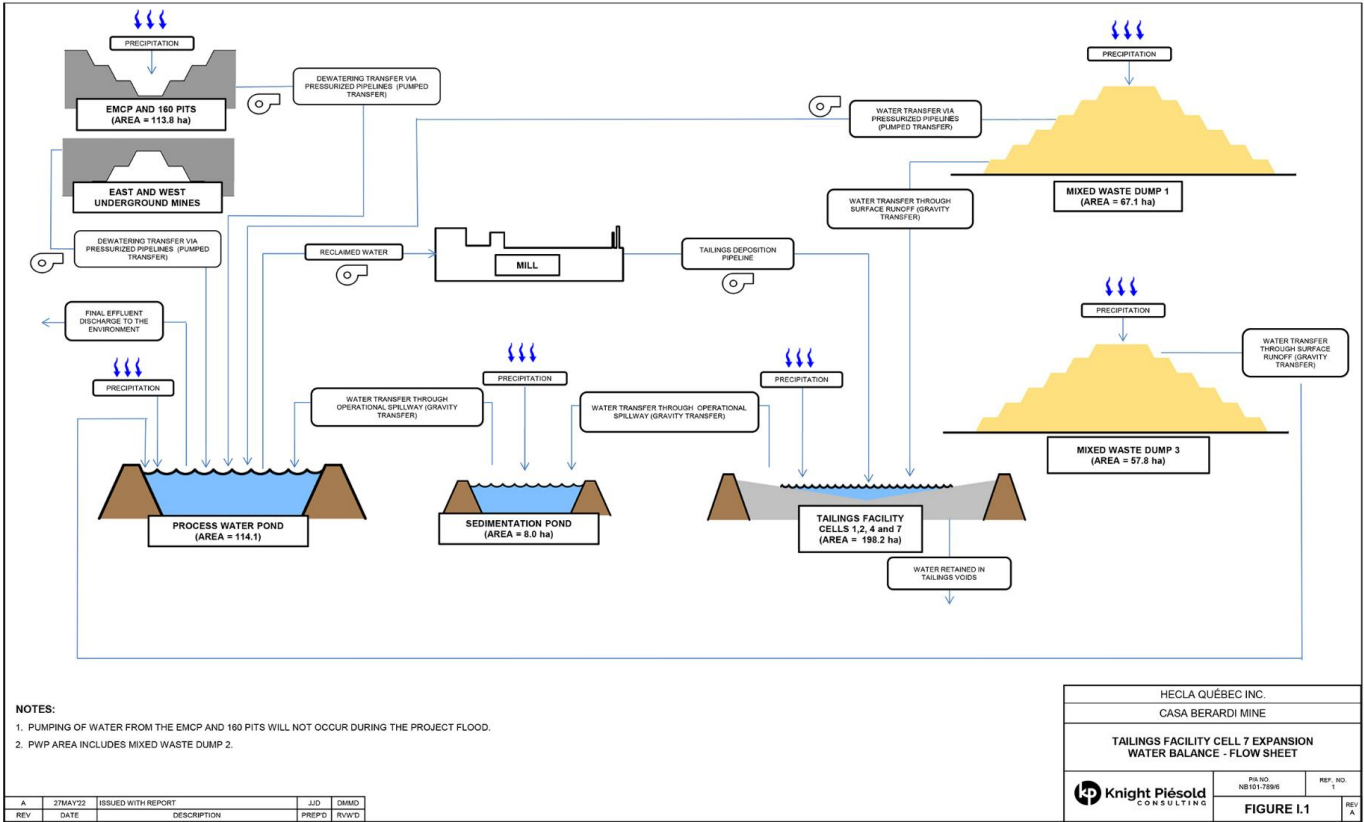

243  
243

## 17.2.2 MINE WATER MANAGEMENT

Mine water from the east and west underground mine dewatering systems is pumped to the surface and treated, when necessary, with ferric sulfate to precipitate arsenic prior to being discharged into the TSF cells. The mine water pumped from open pits is treated, when necessary, in a similar fashion prior to being discharged into the TSF. The mixed ore stockpile contact water is collected and pumped to the TSF. Where practical, the non-contact water is diverted from the site by ditches.

## 17.2.3 TSF WATER MANAGEMENT

Tailings slurry contains elevated levels of cyanide, cyanide metal complexes, cyanide degradation products (cyanate (CNO), thiocyanate (CNS), ammonia (NH<sub>3</sub>)), and arsenic. The primary concern with discharge is elevated levels of these constituents, which could exceed effluent standards and/or cause effluent toxicity.

Casa Berardi uses the SO<sub>2</sub>/air process for cyanide destruction in the slurry discharge prior to release to the TSF. Ferric sulfate is added to the slurry at the exit of the SO<sub>2</sub>/air process, effectively eliminating soluble arsenic from the discharge. While the SO<sub>2</sub>/air process does produce elevated levels of CNO, this compound is not likely to be present in hazardous concentrations, due to its natural degradation to ammonia and other compounds while in the tailings pond. Storage of the water in the tailing ponds, sedimentation pond, and PWP assist in nitrification of the water to reduce ammonia levels.

Hecla is permitted to discharge treated water year-round with no volume limitations. Actual treated water discharge is typically limited to the spring and late fall due to the demand for process water in summer and the inability to meet discharge requirements during the winter. Approximately two to three million cubic meters of process pond water that is not recycled at the mill is discharged annually into Kaakakosig Creek.

The final effluent meets Canada Metal and Diamond Mining Effluent Regulations (MDMER) and the limits outlined in Québec Directive 019 for mining industry discharge. A monitoring program is in place for surface and underground water. Regular monthly monitoring during periods of discharge of final effluent is carried out as required by applicable regulations.

## 17.2.4 ENVIRONMENTAL EFFECTS OF TREATED EFFLUENT

As required by MDMER, Environment Effect Monitoring (EEM) studies are conducted on a regular basis with the analytical results sent to federal regulatory agencies. Monitoring studies began in 2007 and are still in progress. Studies are conducted every three years until the end of mine life.

# 17.3 REGULATORY CHANGE AND ENVIRONMENTAL PERMITS

## 17.3.1 REGULATORY CHANGE

As of August 2018, the Québec territory north of the 49<sup>th</sup> Parallel is no longer subject to the regulation regarding compensation for adverse effects on wetlands and bodies of water under the Environmental Quality Act (R.S.Q., c. Q-2) (the EQA).

244  
244

### 17.3.2 ENVIRONMENTAL PERMITS

All necessary regulatory permits required for the operation of the Casa Berardi Mine, since its construction and that have been transferred or issued to Hecla, are listed in Table 17-1.

245  
245

RSI-M0206.22001

---

**Table STYLEREF 1 \s 17-. Existing Environmental Permits**

<b>Permit #</b>	<b>Permit title</b>	<b>Pursuant</b>	<b>Description</b>	<b>Issued To</b>	<b>Issuance (YYY Y-MM-DD)</b>	<b>Zone</b>
7610-10-01-70016-23	Ore extraction and processing ore	EQA / Section 30	Installation of a secondary crusher(Modified)	Hecla Québec	4/13/2023	Casa Berardi site
22-HQUE-00453	Divert a section of Kaackakosig creek	Fisheries act/Sections 34.4(2)b and 35(2)b)	Divert a section of Kaackakosig creek (Modified)	Hecla Québec	1/31/2023	160 Pit
7610-10-01-70016-23	Ore extraction and processing ore	EQA / Section 30	Cell#7 increasing dyke(Modified)	Hecla Québec	11/29/2022	Casa Berardi site
01-10-0991-20_MOD2	Divert a section of Kaackakosig creek	LCMVF	Divert a section of Kaackakosig creek (Modified)	Hecla Québec	3/8/2022	160 Pit
7610-10-01-70017-43	Open pit 160 (construction and operation)	EQA / Section 30	Expansion of open pit 160 (Modified)	Hecla Québec	2/14/2022	160 Pit
7610-10-01-70016-61	Open pit 160	EQA / Section 30	Expansion of open pit 160 in humid area (Modified)	Hecla Québec	2/14/2022	160 Pit
7610-10-01-70016-23	Ore extraction and processing ore	EQA / Section 30	Cell#7 increasing dyke(Modified)	Hecla Québec	8/20/2021	Casa Berardi site
20-HQUE-00110 - 2021-020	Fisheries Act authorization	Fisheries act/Sections 34.4(2)b and 35(2)b)	Divert a section of Kaackakosig creek (1400 m) to operate 160 open pit	Hecla Québec	7/26/2021	160 Pit

Permit #	Permit title	Pursuant	Description	Issued To	Issuance (YYY Y-MM-DD)	Zone
01-10-0991-20_MOD	Divert a section of Kaackakosig creek	LCMVF	Divert a section of Kaackakosig creek (Modified)	Hecla Québec	7/23/2021	160 Pit
01-10-0991-20	Divert a section of Kaackakosig creek	LCMVF	Divert a section of Kaackakosig creek	Hecla Québec	4/26/2021	160 Pit
7610-10-01-70016-57	Dewatering open pit 160	EQA/Section 30	Installation of 12 dewatering wells at the perimeter of 160 pit (Modified)	Hecla Québec	2/24/2021	160 Pit
7610-10-01-70016-61	Open pit 160	EQA/Section 22	Construction of 160 open pit in Humid area	Hecla Québec	9/16/2020	160 Pit
7610-10-01-70016-57	Dewatering open pit 160	EQA/Section 30	Installation of 12 dewatering wells at the perimeter of 160 pit (Modified)	Hecla Québec	9/15/2020	160 Pit
7610-10-01-70017-43	Open pit 160 (construction and operation)	EQA/Section 30	Open pit 160 (construction and operation)	Hecla Québec	9/15/2020	160 Pit
7610-10-01-70016-48	Raise of the water process pond dyke	EQA/Section 30	Raise of the water process pond dyke (Modified)	Hecla Québec	9/4/2020	Casa Berardi site
7610-10-01-70016-56	Ore crushing	EQA/Section 30	Ore crushing on Casa Berardi site (Modified)	Hecla Québec	7/14/2020	Casa Berardi site
7610-10-01-70016-57	Dewatering of open pit 134	EQA/Section 22	Dewatering 134	Hecla Québec	5/27/2020	134 Pit
7610-10-01-70016-58	Construction and operation of open pit 134 in humid area	EQA/Section 22	Construction and operation of open pit 134 and stockpile #3 in humid area	Hecla Québec	5/27/2020	134 Pit
7610-10-01-70017-43	Open pit 134	EQA/Section 30	Open pit 134 (construction and operation) and stockpile #3	Hecla Québec	5/27/2020	134 Pit

Permit #	Permit title	Pursuant	Description	Issued To	Issuance (YYY Y-MM-DD)	Zone
7610-10-01-70016-51	Raise of internal dyke cell#4	EQA/Section 30	Raise internal dyke in cell#4 third step (Modified)	Hecla Québec	3/27/2020	Casa Berardi site
7610-10-01-70016-51	Raise of internal dyke cell#4	EQA/Section 30	Construction of filter dams in cell#1 (Modified)	Hecla Québec	3/11/2020	Casa Berardi site
7610-10-01-70017-07	Attestation d'assainissement en milieu industriel (permit of operation)		Attestation d'assainissement en milieu industriel (Modified)	Hecla Québec	1/9/2020	Casa Berardi site
7610-10-01-70016-56	Ore crushing	EQA/Section 30	Ore crushing on Casa Berardi site (Modified)	Hecla Québec	10/16/2019	Casa Berardi site
7610-10-01-70017-43	Open pit EMCP	EQA/Section 30	Ore stockpile #2	Hecla Québec	9/13/2019	Casa Berardi site
7610-10-01-70016-23	Ore extraction and processing ore	EQA / Section 30	Adding a tank and a compressor at the cyanide destruction	Hecla Québec	9/11/2019	Casa Berardi site
7610-10-01-70016-56	Ore crushing	EQA/Section 22	Ore crushing on Casa Berardi site	Hecla Québec	6/25/2019	Casa Berardi site
7610-10-01-70016-55	Extension of EMCP	EQA/Section 22	XMCP open pit	Hecla Québec	5/15/2019	XMCP pit
7610-10-01-70016-23	Ore extraction and processing ore	EQA / Section 30	Increase tonnage at the mill (Modified)	Hecla Québec	4/4/2019	Casa Berardi site

Permit #	Permit title	Pursuant	Description	Issued To	Issuance (YYY-MM-DD)	Zone
7610-10-01-70016-54	Expansion of tailing pond cell#7	EQA/Section 22	Construction of cell#7	Hecla Québec	2/27/2019	Casa Berardi site
7610-10-01-70016-51	Raise of internal dyke cell#4	EQA/Section 30	Raise internal dyke in cell#4 works 2018-2019 (Modified)	Hecla Québec	12/19/2018	Casa Berardi site
7610-10-01-70016-53	Closure of cell#2	EQA/Section 22	Construction of a clay cover on cell#2	Hecla Québec	12/19/2017	Casa Berardi site
7610-10-01-70016-23	Ore extraction and processing ore	EQA / Section 122.2	Increase tonnage at the mill (Modified)	Hecla Québec	8/25/2017	Casa Berardi site
7610-10-01-70016-52	Raise dyke cell#4	EQA/Section 22	Raise dyke cell#4	Hecla Québec	8/15/2017	Casa Berardi site
7610-10-01-70016-51	Raise of internal dyke cell#4	EQA/Section 22	Raise internal dyke in cell#4	Hecla Québec	4/5/2017	Casa Berardi site
7610-10-01-70016-50	Use of leachable waste rock for construction in stockpile #1 and in tailing pond	EQA/Section 22	Use of leachable waste rock for construction in stockpile #1 and in tailing pond	Hecla Québec	1/13/2017	Casa Berardi site
7610-10-01-70017-34	Expansion of the ore stockpile at west mine	EQA/Section 122.2	Expansion of the ore stockpile at west mine (Modified)	Hecla Québec	12/20/2016	Casa Berardi site

Permit #	Permit title	Pursuant	Description	Issued To	Issuance (YYY Y-MM-DD)	Zone
7610-10-01-70016-23	Ore extraction and processing ore	EQA / Section 122.2	Increase tonnage at the mill (Modified)	Hecla Québec	10/17/2016	Casa Berardi site
7610-10-01-70016-23	Ore extraction and processing ore	EQA / Section 122.2	Increase tonnage at the mill (Modified)	Hecla Québec	8/3/2016	Casa Berardi site
7610-10-01-70016-48	Raise of the water process pond dyke	EQA/Section 22	Raise of the water process pond dyke	Hecla Québec	6/23/2016	Casa Berardi site
7610-10-01-70016-49	Crushing and screening of waste rock	EQA/Section 22	Crushing and screening of waste rock	Hecla Québec	2/25/2016	Casa Berardi site
7610-10-01-70016-47	Dewatering EMCP	Règlement sur le captage des eaux souterraines/ Section 31.75 and 31.95	Dewatering EMCP and installation of the pumping station	Hecla Québec	1/12/2016	EMCP pit
7610-10-01-70017-43	Open pit EMCP	EQA/Section 22	Open pit EMCP (construction and operation)	Hecla Québec	10/29/2015	EMCP pit
7610-10-01-70016-41	Tailing pond	EQA/Section 122.2	Raise north dyke of cell#4 and water process pond pumping station redevelopment (Modified)	Hecla Québec	10/21/2015	Casa Berardi site
7610-10-01-70016-41	Tailing pond	EQA/Section 122.2	Raise internal dyke in southern part of cell#4 (Modified)	Hecla Québec	8/12/2015	Casa Berardi site

Permit #	Permit title	Pursuant	Description	Issued To	Issuance (YYY-Y-MM-DD)	Zone
7610-10-01-70017-07	Attestation d'assainissement en milieu industriel (permit of operation)		Attestation d'assainissement en milieu industriel (Modified)	Hecla Québec	1/12/2015	Casa Berardi site
7610-10-01-70017-44	Underground water collection at west mine	EQA/Section 31.75	Increasing the capacity of the water collection	Hecla Québec	12/18/2014	Casa Berardi site
7610-10-01-70017-45	Drinking water distribution	EQA/Section 32	Drinking water distribution	Hecla Québec	12/18/2014	Casa Berardi site
7610-10-01-70017-46	Underground water collection at west mine	EQA/Section 31.75	Installation of a new well and water collection at West mine	Hecla Québec	12/18/2014	Casa Berardi site
7610-10-01-70016-46	Construction of 8 pads for drilling in humid area	EQA/Section 22	Construction of 8 pads for drilling in humid area	Hecla Québec	12/15/2014	Casa Berardi site
7610-10-01-70016-43	Increase water collection	EQA/Section 31.75	Increase underground water collection at East mine	Hecla Québec	11/28/2014	Casa Berardi site
7610-10-01-70016-28	Operation of a concrete plant	EQA/Section 122.2	Operation of a concrete plant (transferred)	Hecla Québec	2/5/2014	Casa Berardi site
7610-10-01-70016-39	Oil and water separator	EQA/Section 122.2	Treatment of oily water (transferred to Hecla Québec)	Hecla Québec	2/5/2014	Casa Berardi site

Permit #	Permit title	Pursuant	Description	Issued To	Issuance (YYY Y-MM-DD)	Zone
7610-10-01-70017-28	Oil and water separator	EQA/Section 122.2	Oil and water separator (transferred to Hecla Québec)	Hecla Québec	2/5/2014	Casa Berardi site
7610-10-01-70017-41	Operation of cement plant	EQA/Section 122.2	Operation of a cement plant (transferred to Hecla Québec)	Hecla Québec	2/5/2014	Casa Berardi site
7610-10-01-70016-42	Dewatering and backfill a pond	EQA/Section 22	Dewatering and backfill a man-made pond	Hecla Québec	1/14/2014	Casa Berardi site
7610-10-01-70016-45	Construction access and pads for drilling in humid area	EQA/Section 22	Construction access and pads for drilling in humid area	Hecla Québec	12/19/2013	Casa Berardi site
7610-10-01-70017-36	Operation of a Bekosplit unit	EQA/Section 122.2	Operation of a Bekosplit unit (Modification)	Hecla Québec	11/21/2013	Casa Berardi site
7470-10-01-00006-04	Construction of access road in a humid area	EQA / Section 22	Construction of access and pads for drilling in humid area	Hecla Québec	6/28/2013	West mine
7610-10-01-70016-39	Oil and water separator	EQA/Section 22	Treatment of oily water modification	Aurizon Mines Ltd	6/7/2013	Casa Berardi site
7610-10-01-70016-25	Quarry	EQA / Section 22	Quarry exploitation	Aurizon Mines Ltd	5/10/2013	Casa Berardi site
7610-10-01-70016-44	Construction of access road in a humid area	EQA/Section 22	Construction of access road in a humid area	Aurizon Mines Ltd	3/14/2013	Casa Berardi site

Permit #	Permit title	Pursuant	Description	Issued To	Issuance (YYY Y-MM-DD)	Zone
7610-10-01-70017-40	Operation of a paste backfill plant	EQA/Section 122.2	Construction and operation of a paste backfill plant (Modification)	Aurizon Mines Ltd	3/7/2013	West mine
7610-10-01-70017-40	Operation of a paste backfill plant	EQA/Section 22	Construction and operation of a paste backfill plant transferred on 05-02-2014	Aurizon Mines Ltd	10/29/2012	Casa Berardi site
7610-10-01-70017-41	Operation of cement plant	EQA/Section 22	Operation of a cement plant	Aurizon Mines Ltd	9/26/2012	Casa Berardi site
7610-10-01-70016-41	Tailing pond	EQA/Section 22	Raise and extension of cell# 4 dyke modified on February 5 2014	Aurizon Mines Ltd	5/9/2012	Casa Berardi site
7610-10-01-70016-38	Underground water collection	Règlement sur le captage des eaux souterraines/ Section 31.75	Underground water collection at East mine	Aurizon Mines Ltd	4/2/2012	Casa Berardi site
7610-10-01-70017-39	Underground water collection at west mine	Règlement sur le captage des eaux souterraines/ Section 31	Underground water collection at west mine	Aurizon Mines Ltd	4/2/2012	Casa Berardi site
7470-10-01-00006-03	Construction of access road in a humid area	EQA / Section 22	Construction of access and pads for drilling in humid area	Aurizon Mines Ltd	2/24/2012	West mine
7610-10-01-70016-37	Ore extraction and processing ore	EQA/Section 22	Tailing pond cell#4 construction (modification)	Aurizon Mines Ltd	11/21/2011	Casa Berardi site

Permit #	Permit title	Pursuant	Description	Issued To	Issuance (YYY Y-MM-DD)	Zone
7610-10-01-70017-07	Attestation d'assainissement en milieu industriel (permit of operation)		Attestation d'assainissement en milieu industriel	Aurizon Mines Ltd	11/11/2011	Casa Berardi site
7610-10-01-70017-38	Treatment for domestic wastewater	EQA/Section 32	Treatment for domestic wastewater (Bionest west mine)	Aurizon Mines Ltd	9/21/2011	Casa Berardi site
7610-10-01-70016-39	Oil and water separator	EQA/Section 22	Treatment of oily water	Aurizon Mines Ltd	8/26/2011	Casa Berardi site
7610-10-01-70016-39	Bekosplit	EQA/Section 22	Operation of a Bekosplit unit	Aurizon Mines Ltd	6/17/2011	Casa Berardi site
7610-10-01-70016-40	Bekosplit	EQA/Section 32	Installation of a Bekosplit unit	Aurizon Mines Ltd	6/17/2011	Casa Berardi site
7610-10-01-70017-25	Casa Berardi west mine exploitation	EQA/Section 122.2	Casa Berardi west mine exploitation (Modification)	Aurizon Mines Ltd	2/21/2011	Casa Berardi site
7610-10-01-70017-35	Construction of access road and pad for drilling in a humid area	EQA/Section 22	Construction of access road and pad for drilling in a humid area	Aurizon Mines Ltd	10/17/2010	Casa Berardi site
7610-10-01-70016-37	Ore extraction and processing ore	EQA/Section 22	Tailing pond cell#4 construction modified on February 5 2014	Aurizon Mines Ltd	7/29/2010	Casa Berardi site

Permit #	Permit title	Pursuant	Description	Issued To	Issuance (YYY Y-MM-DD)	Zone
7610-10-01-70017-34	Ore stockpile at west mine	EQA/Section 22	Ore stockpile at west mine	Aurizon Mines Ltd	6/30/2010	Casa Berardi site
7470-10-01-00006-00	Construction of access road in a humid area	EQA / Section 22	Construction of access and pads for drilling in humid area	Aurizon Mines Ltd	1/14/2010	West mine
7610-10-01-70016-33	Oil and water separator	EQA/Section 22	Installation of an oil and water separator in mechanical shop at East mine (modification)	Aurizon Mines Ltd	12/18/2009	Casa Berardi site
7610-10-01-70016-36	Treatment for domestic wastewater	EQA/Section 32	Treatment for domestic wastewater Bionest est modified on February 5 2014	Aurizon Mines Ltd	11/3/2009	Casa Berardi site
7610-10-01-70017-33	Construction of access road in a humid area	EQA/Section 22	Construction of access road in a humid area	Aurizon Mines Ltd	7/17/2009	Casa Berardi site
7610-10-01-70017-31	Oil and water separator West mine	EQA/Section 22	Operation of an oil and water separator West mine Garage Gabriel Aubé	Aurizon Mines Ltd	1/13/2009	Casa Berardi site
7610-10-01-70017-32	Oil and water separator West mine	EQA/Section 32	Installation of an oil and water separator West mine Garage Gabriel Aubé	Aurizon Mines Ltd	1/13/2009	Casa Berardi site
7610-10-01-70016-33	Oil and water separator	EQA/Section 22	Installation of an oil and water separator in mechanical shop at East mine modified on May 2, 2014	Aurizon Mines Ltd	6/26/2008	Casa Berardi site
7610-10-01-70017-27	Treatment for domestic wastewater	EQA/Section 122.2 and 122.3	Treatment for domestic waste (Modification)	Aurizon Mines Ltd	5/29/2008	Casa Berardi site

Permit #	Permit title	Pursuant	Description	Issued To	Issuance (YYY Y-MM-DD)	Zone
7610-10-01-70017-30	Construction of access road in a humid area	EQA/Section 22	Construction of access road in a humid area	Aurizon Mines Ltd	4/9/2008	Casa Berardi site
7610-10-01-70016-32	Installation of a humid dust collector and a dust collector	EQA/Section 48	Installation of a humid dust collector and a dust collector modified on February 5 2014	Aurizon Mines Ltd	4/7/2008	Casa Berardi site
7610-10-01-70016-23	Ore extraction and processing ore	EQA / Section 122.2	Tailing pond filing plan cell# 1, 2 and 3	Aurizon Mines Ltd	12/19/2007	Casa Berardi site
7610-10-01-70017-28	Oil and water separator	EQA/Section 22	Oil and water separator west mine	Aurizon Mines Ltd	10/17/2007	Casa Berardi site
7610-10-01-70017-29	Construction of access road in a humid area	EQA/Section 22	Construction of access road in a humid area	Aurizon Mines Ltd	7/20/2007	Casa Berardi site
7610-10-01-70016-23	Ore extraction and processing ore	EQA / Section 122.2	Increase process water pond dyke	Aurizon Mines Ltd	9/14/2006	Casa Berardi site
7610-10-01-70017-27	Treatment for domestic wastewater	EQA/Section 32	Treatment for domestic waste	Aurizon Mines Ltd	8/15/2006	Casa Berardi site
7610-10-01-70017-26	Installation of a power line of 25 kV	EQA/Section 22	Installation of a power line 25kV in a humid area modified on February 5 2014	Aurizon Mines Ltd	1/26/2006	Mine Oues t
7610-10-01-70016-31	Installation of a fire station	EQA/Section 32	Installation of a fire station in «Lac Sans Nom» (modified)	Aurizon Mines Ltd	9/22/2005	Casa Berardi site

Permit #	Permit title	Pursuant	Description	Issued To	Issuance (YYY Y-MM-DD)	Zone
7610-10-01-70016-31	Installation of a fire station	EQA/Section 32	Installation of a fire station in «Lac Sans Nom» modified on February 5 2014	Aurizon Mines Ltd	7/4/2005	Casa Berardi site
7610-10-01-70016-30	Pipe installation in Koababikawi creek	EQA/Section 32	Installation of 2 pipes in Koababikawi creek for fire station and industrial water modified on February 5 2014	Aurizon Mines Ltd	11/10/2004	Mine Est
7610-10-01-70016-23	Ore extraction and processing ore	EQA / Section 122.2	Increase tonnage at the mill (Modification)	Aurizon Mines Ltd	9/10/2001	Casa Berardi site
7610-10-01-70017-25	Casa Berardi west mine exploitation	EQA/Section 122.2	Casa Berardi west mine exploitation (Modification)	Aurizon Mines Ltd	10/27/2000	Casa Berardi site
7610-10-01-70016-21	Diversion of Kaackakosig creek	EQA / Section 22	Diversion of Kaackakosig creek Casa Berardi East, transferred to Aurizon mines on September 14 1998, transferred to Hecla on February 5 2014	Aurizon Mines Ltd	9/14/1998	Casa Berardi site
7610-10-01-70016-23	Ore extraction and processing ore	EQA / Section 24	Ore extraction and processing ore transferred to Aurizon Mines Ltd	Aurizon Mines Ltd	9/14/1998	Casa Berardi site
7610-10-01-70016-24	Clay borrow pit	EQA / Section 24	Clay borrow pit exploitation (transferred)	Aurizon Mines Ltd	9/14/1998	Casa Berardi site
7610-10-01-70016-25	Quarry	EQA / Section 24	Quarry exploitation (transferred)	Aurizon Mines Ltd	9/14/1998	Casa Berardi site

Permit #	Permit title	Pursuant	Description	Issued To	Issuance (YYY Y-MM-DD)	Zone
7610-10-01-70016-26	Clay borrow pit	EQA/Section 24	Clay borrow pit exploitation (transferred)	Aurizon Mines Ltd	9/14/1998	Casa Berardi site
7610-10-01-70017-25	Casa Berardi west mine exploitation	EQA/Section 24	Casa Berardi west mine exploitation (transferred)	Aurizon Mines Ltd	9/14/1998	West mine
7610-10-01-70016-23	Ore extraction and processing ore	EQA / Section 22	Ore extraction and processing ore (Modification)	TVX Gold and Golden Knight Resources	2/19/1998	Casa Berardi site
7610-10-01-86019-00	Operation of cement plant	EQA/Section 22	Operation of a cement plant transferred to Aurizon Mines Ltd on September 14,1998 (761010-01-70016-28)	TVX Gold	11/6/1995	Casa Berardi site
7610-10-01-70016-00	Clay borrow pit	EQA / Section 22	Clay borrow pit exploitation	Les mines Casa Berardi	9/18/1995	Casa Berardi site
7610-10-01-70016-26	Clay borrow pit	EQA/Section 22	Clay borrow pit exploitation	TVX Gold	9/18/1995	Casa Berardi site
7610-10-01-70016-24	Clay borrow pit	EQA / Section 22	Clay borrow pit exploitation	TVX Gold	8/7/1995	Casa Berardi site
7610-10-01-70016-25	Quarry	EQA / Section 22	Quarry exploitation (transferred)	TVX Gold	8/7/1995	Casa Berardi site
7610-10-01-70016-23	Ore extraction and processing ore	EQA / Section 22	Ore extraction and processing ore	TVX Gold and Golden Knight Resources	12/23/1992	Casa Berardi site

Permit #	Permit title	Pursuant	Description	Issued To	Issuance (YYY Y-MM-DD)	Zone
7610-10-01-70017-00	Casa Berardi west mine exploitation	EQA/Section 22	Casa Berardi mine west mine exploitation transferred to Hecla Québec on February 5, 2014	Hecla Québec	7/2/1992	Casa Berardi site
7610-10-01-70016-09	Storage for dangerous waste	EQA / Section 22	Storage for dangerous waste transferred to TVX gold and Golden Knight Resources on June 19, 1992	TVX Gold and Golden Knight Resources	6/19/1992	Casa Berardi site
7610-10-01-70016-22	Storage for dangerous waste	EQA / Section 22	Storage for dangerous waste	Les mines Casa Berardi	1/18/1991	Casa Berardi site
7610-70049-00	Exploitation and operation of Casa Berardi west	EQA/Section 22	Exploitation and operation of Casa Berardi west	Inco Gold	6/29/1990	Casa Berardi site
7610-10-01-70016-21	Diversion of Kaackakosig creek	EQA / Section 22	Diversion of Kaackakosig creek Casa Berardi East	Inco Gold	2/19/1990	Casa Berardi site
7610-10-01-70017-22	Treatment for domestic wastewater (projet C)	EQA/Section 32	Treatment for domestic wastewater (projet C)	TVX Gold and Golden Knight Resources	9/10/1987	Casa Berardi site
7610-10-01-70017-21	Treatment for domestic wastewater at Golden Pond West	EQA/Section 32	Treatment for domestic wastewater at Golden Pond West	TVX Gold and Golden Knight Resources	7/26/1987	Casa Berardi site

### 17.3.3 ENVIRONMENTAL IMPACT ASSESSMENT

As described in Section 17.1, the current LOM plan incorporates the conclusion of underground mining activities during 2024 and mining of the F160 Pit into 2026. The planned development of the preliminary Principal, WMCP, and F134 pits along with their associated waste dumps and other surface infrastructure has the potential to trigger an Environmental Impact Assessment (EIA) for the Property. Hecla plans to initiate the process of this evaluation in April 2024 by submitting the project notice to the Provincial Ministère de l'Environnement, de la Lutte contre les changements climatiques, de la Faune et des Parcs (MELCCFP). The notice will include an overview of the proposed development and a description of the plan of operations. Baseline studies, which have been ongoing at the Property since 2019 for normal operational monitoring, will provide data that will inform future mine permit applications, operational plans, and portions of the EIA. The overall EIA process typically takes several years to complete and considers the potential environmental, health, and social and economic impact of a proposed project, including the benefits of the project. Hecla expects multiple regulatory agencies to be involved with the process along with public comment periods.

## 17.4 MINE RECLAMATION AND CLOSURE

The most recent reclamation and closure plan was submitted in October 2019 and accepted in September 2020. This plan covers the global reclamation of the mine site, including the restoration of the EMCP, XMCP and F134 pits. It also includes the reclamation of Mixed Stockpile #3 and the construction of the first stage of Cell #7 of the tailings compound, which are the most recently authorized infrastructure on the Casa Berardi property. Reclamation plans must be updated every five years and submitted to the Ministère Ressources Naturelles et de la Faune (MRNF) for approval. The next update to the reclamation and closure plan for Casa Berardi is planned to be submitted to the MRNF in November 2024.

The Casa Berardi reclamation and closure plan includes:

- / Decommissioning of the surface infrastructure.
- / Dismantling of all surface structures, with sales/recycling of assets and disposal of wastes.
- / Grading and revegetation of all disturbed areas.
- / Capping/sealing of all mine access points in accordance with regulatory standards.
- / Grading of the tailing dikes followed by direct vegetation of the tailings dams.
- / Description of the financial guarantee, the amount of which corresponds to the anticipated costs of the reclamation work.
- / The closure period, which will include five years of monitoring activities.

Since August 2013, mining regulations require that financial guarantees cover all reclamation costs including dismantling of the headframes and buildings and sealing of all openings. The amount of this guarantee, which is in the form of a surety bond, corresponds to the total estimated costs for the reclamation of the entire actual mine site. The guarantee must be provided in three installments within two years of the date of reclamation plan approval. The estimated cost for reclamation and closure for the Casa Berardi site is US\$22,829,757 (C\$29,107,949).

This cost estimate covers the existing operations and current infrastructure but does not include the cost for reclamation and closure of future open pits. An update to the reclamation and closure plan along with calculations for closure costs are planned to be performed by Hecla in late 2024.

## 17.5 COMMUNITY AND SOCIAL ASPECTS

The Abitibi region is a well-established and mature mining area, with the mining industry being a key component of regional economic development. The area has a wealth of trained miners, and continued development of the mine is viewed by most residents as a positive activity that provides employment and tax revenue for the region. For instance, Hecla contributed over US\$450,000 (C\$548,700) in donations and sponsorships in 2022 to various organizations in the region.

Hecla has developed community engagement and integrated social responsibility policies and has a good relationship with stakeholders. Since January 2019, Hecla has established a liaison committee composed of stakeholders from a variety of areas, including municipal, Indigenous, economic, environmental, and educational communities, as seen in Table 17-2.

**Table STYLEREF 1 \s 17-. Total Contributions to Regional Organizations from 2018 to 2022**

Year	Total Contributed (US\$)	Total Contributed (C\$)
2022	450,039	548,718
2021	363,837	463,892
2020	352,862	449,899
2019	406,377	518,131
2018	469,100	598,102

The Casa Berardi property is situated on the territory of the Abitibiwinni First Nation, more precisely the community of Pikogan. In November 2018, Hecla and the Council of the Abitibiwinni First Nation signed a Memorandum of Understanding (MOU) regarding Hecla's exploration and mining activities in the Casa Berardi area. On December 9, 2020, and in accordance with the MOU, the parties agreed upon a negotiation process for collaboration. Employment, training, and business were identified as areas of opportunity for members of the Abitibiwinni First Nation.

## 17.6 COMMENTS ON ENVIRONMENTAL STUDIES, PERMITTING, AND COMMUNITY IMPACT

RESPEC is of the opinion that the environmental, permitting, and social aspects of the Property are being appropriately managed and planned to support the current LOM plan to 2037.

In the opinion of RESPEC:

261  
261

- / Hecla has sufficiently addressed the environmental impacts of the operation, and subsequent closure and reclamation requirements such that the mine plan is deemed appropriate and achievable. Closure provisions are appropriately considered, and monitoring programs are in place.
- / Current permits held by Hecla for the Property are sufficient to ensure that surface and underground mining activities which will take place into 2026 are conducted in accordance with the local, provincial, and national regulatory frameworks.
- / Beyond 2026, the LOM plan includes the development of three additional open pits along with associated waste rock storage facilities and other infrastructure. This planned development may require an EIA to be performed at the property. Hecla will submit a project notice to the Provincial MELCCFP in 2024. Hecla expects the EIA process to take several years to complete and that mining of the planned open pits can take place in accordance with local, provincial, and national regulatory frameworks.
- / Hecla has developed a community' relations plan to identify and ensure an understanding of the needs of the surrounding communities and to determine appropriate programs for addressing those needs. Hecla appropriately monitors socio-economic trends, community perceptions, and mining impacts.
- / There are currently no known environmental, permitting, or social/community risks that could impact the extraction of Mineral Resources or Mineral Reserves at the Property.

## 18.0 CAPITAL AND OPERATING COSTS

### 18.1 CAPITAL COSTS

Please refer to the note regarding forward-looking information at the front of this report. Unless otherwise noted, all dollar amounts are presented in United States dollars based on a US\$/C\$ exchange rate of 1.35, and all other measurements are metric values.

Casa Berardi uses the LOM plan as the planning guide for the Casa Berardi operation. The LOM capital costs total US\$500 million and include mine development (contractor and owner), mine infrastructure, open pit costs, equipment costs, environmental permitting, and tailings management (Table 18-1) RESPEC is of the opinion that the estimated capital costs for Casa Berardi are reasonable.

263  
263

RSI-M0206.22001

---

Description	Units	Total	2024	2025	2026	2027	2028	2029	2030	2031	2032	2033	2034	2035	2036	2037
Ore Processing	US\$(000)	90,123	56,275	20,270	13,578	-	-	-	-	-	-	-	-	-	-	-
Major Projects	US\$(000)	10,352	1,463	2,963	2,963	2,963	-	-	-	-	-	-	-	-	-	-
Administration	US\$(000)	387	209	178	-	-	-	-	-	-	-	-	-	-	-	-
Mine Stripping, Mine Infrastructure	US\$(000)	302,754	-	-	-	-	23,773	47,159	53,758	52,964	61,355	63,744	-	-	-	-
Mobile Equipment	US\$(000)	94,813	3,098	11,523	-	6,823	7,277	25,111	17,276	6,847	2,240	4,072	3,515	3,515	3,515	-
Total Operating Capital Costs USD\$	US\$(000)	498,428	61,045	34,934	16,541	9,786	31,050	72,270	71,034	59,811	63,596	67,816	3,515	3,515	3,515	-
Salvage Value	US\$(000)	(19,736)	-	-	-	-	-	-	-	-	-	-	-	-	-	(19,736)

264  
264

Reclamation & Closure	US\$(000)	21,561	-	-	-	-	-	-	-	-	-	-	-	-	-	21,561
Total Capital Costs US\$	US\$(000)	500,253	61,045	34,934	16,541	9,786	31,050	72,270	71,034	59,811	63,596	67,816	3,515	3,515	3,515	1,825

**Table STYLEREF 1 \s 18-. LOM Capital Costs**

265  
265

RSI-M0206.22001

The capital costs are based on updates from equipment suppliers and verified with engineering companies providing services to Casa Berardi. The capital costs accuracy would be considered +/-15% with zero contingency.

Major Projects include permitting costs for the LOM which include environmental, hydrogeological, and geotechnical studies, and condemnation drilling. Mine Stripping includes the overburden removal from WMCP and Principal pits. Open pit costs include mobilization of the open pit contractor and capitalized stripping costs. In 2037, there is a salvage value of approximately US\$19.7 million for mine and other equipment that can be sold.

## 18.2 OPERATING COSTS

The operating costs for the Casa Berardi Mine for 2022 and 2023 are presented in Table 18-2. Gold production in 2022 and 2023 was lower than budget due to lower tonnes processed from the underground. Total open pit tonnes moved were higher in 2022 and slightly lower in 2023 with better than planned unit costs for both years. With the future of the property being almost exclusively open pit, RESPEC is of the opinion that the actual operating costs support the LOM operating costs.

266  
266

RSI-M0206.22001

---

**Table STYLEREF 1 \s 18-. 2020 and 2021 Operating Cost Data**

Item	Material Produced	
	2022	2023
Tonnes Processed (kt)	1,441	1,312
Gold Produced (k toz)	127.6	90.4
	Operating Cost	
	(US\$/t milled)	
UG Mine (West)	75.60	88.47
UG Mine (East)	86.72	155.10
Site Services (Mech & Elect.)	23.34	19.40
Administration	11.39	6.86
Environment	1.57	1.41
Geology	1.76	2.17
Engineering	2.72	2.07
Health and Safety	2.08	1.69
Open Pit - EMCP	0.00	0.00
Open Pit - F160	25.50	19.35
Mill	28.95	23.82
Backfill Paste Plant	0.96	0.93
<b>Total Operating Costs</b>	<b>130.41</b>	<b>112.42</b>

### 18.2.1 LOM OPERATING COSTS

The LOM operating costs and unit operating costs are presented in Table 18-3 and Table 18-4, respectively. The mining cost decreases substantially after 2024 when only open pit mining will be conducted for the balance of the LOM period ending in 2037. The LOM unit operating costs compare well with the recent and current operating costs. Operating costs accuracy would be considered +/-15% with zero contingency.

Table STYLEREF 1 \s 18-. LOM Operating Costs

Description	Units	Total	2024	2025	2026	2027	2028	2029	2030	2031	2032	2033	2034	2035	2036	2037
Tonnes Milled	t (000)	14,383	1,310	1,300	1,300	75	-	-	383	1,600	1,600	1,600	1,600	1,600	1,600	413
Mining	US\$(000)	395,611	66,797	22,049	486	-	-	-	25,634	47,627	36,959	33,503	104,520	28,237	17,723	12,075
Processing	US\$(000)	330,271	30,086	29,855	29,855	1,730	-	-	8,786	36,744	36,744	36,744	36,744	36,744	36,744	9,493
Administration	US\$(000)	71,704	19,111	16,593	3,111	2,815	2,815	2,815	2,222	3,556	3,556	3,556	3,556	3,556	3,556	889
<b>Total Cost</b>	<b>US\$(000)</b>	<b>797,586</b>	<b>115,995</b>	<b>68,497</b>	<b>33,452</b>	<b>4,545</b>	<b>2,815</b>	<b>2,815</b>	<b>36,642</b>	<b>87,927</b>	<b>77,259</b>	<b>73,803</b>	<b>144,820</b>	<b>68,537</b>	<b>58,023</b>	<b>22,457</b>

Table STYLEREF 1 \s 18-. LOM Unit Operating Costs

Description	Units	Average	2024	2025	2026	2027	2028	2029	2030	2031	2032	2033	2034	2035	2036	2037
Mining	US\$/t	27.51	50.98	16.96	0.37	-	-	-	66.99	29.76	23.10	20.94	65.32	17.65	11.08	29.21
Processing	US\$/t	22.96	22.96	22.96	22.96	22.96	-	-	22.96	22.96	22.96	22.96	22.96	22.96	22.96	22.96
Administration	US\$/t	4.99	14.59	12.76	2.39	37.36	-	-	5.81	2.22	2.22	2.22	2.22	2.22	2.22	2.15
<b>Total Cost</b>	<b>US\$/t</b>	<b>55.45</b>	<b>88.53</b>	<b>52.68</b>	<b>25.73</b>	<b>60.32</b>	<b>-</b>	<b>-</b>	<b>95.77</b>	<b>54.95</b>	<b>48.28</b>	<b>46.12</b>	<b>90.50</b>	<b>42.83</b>	<b>36.26</b>	<b>54.32</b>

268  
268

## 19.0 ECONOMIC ANALYSIS

Please refer to the note regarding forward looking information at the front of this Report. The economic analysis contained in this TRS is based on the Casa Berardi Proven and Probable Mineral Reserves material only, economic assumptions, and capital and operating costs provided by Hecla's technical team in its LOM plan model and reviewed by RESPEC. All costs in this section are expressed in US dollars and all measurements are in metric values. Unless otherwise stated, all costs in this section of the TRS are expressed without allowance for escalation or currency fluctuation. All costs received from Hecla's site technical team in its Casa Berardi LOM 2024 Reserves only model were quoted in Canadian dollars and were converted to US dollars at an exchange rate of US\$1 = C\$1.35.

A summary of the key project criteria is provided in the subsequent subsections.

### 19.1 ECONOMIC CRITERIA

#### 19.1.1 PHYSICALS

- / Mine life: 14 year LOM (between years 2024 and 2037)
- / Open Pit operations
  - » Open pit mine life: 14 years (between years 2024 and 2037)
  - » Total ore tonnes mined: 14.2Mt at 2.72g/t Au
  - » Waste tonnes: 219Mt
  - » Maximum mining rate: 87ktpd (ore + waste)
- / Underground operations
  - » Underground mine life: 1 year (2024)
  - » Total ore tonnes mined: 209kt at 4.84g/t Au
  - » Maximum mining rate: 1,200tpd
- / Processing of Mineral Reserves:
  - » Total Ore Feed to Plant: 14.4Mt
    - Gold grade: 2.75g/t Au
  - » Maximum milling rate: 4,400tpd
  - » Contained Metal
    - Gold: 1.27Moz Au
  - » Average LOM Plant Recovery 81.5%
  - » Recovered Metal
    - Gold: 1.04Moz Au

269  
269

### 19.1.2 REVENUE

- / RESPEC conducted a preliminary economic analysis using Mineral Reserve pricing of US\$1,650/oz Au and confirmed the mine was economic at those prices.
- / For the purposes of this economic analysis described in this section, revenue is estimated over the LOM with a flat long-term price of US\$1,950/oz Au. RESPEC considers this price to be aligned with the latest industry consensus, long-term forecast prices. Transportation, insurance, and refining charges are estimated at US\$4.07/oz Au over the LOM. Payable metals in the Casa Berardi LOM 2024 plan are estimated at 99.9% for gold and 99.0% for silver. These rates are based on actual figures for refining losses. Silver credits have been estimated based on historical performance of the site.
- / LOM net revenue is US\$2,021 million (after Refining Charges).

### 19.1.3 CAPITAL COSTS

- / Total operating capital costs total US\$498 million
- / Closure costs of US\$21.6 million and a salvage value of \$19.7 million are included in the analysis at the end of the LOM.

### 19.1.4 OPERATING COSTS

- / Open Pit mining: US\$26.45/t ore mined
- / Underground mining: US\$106.23/t ore mined
- / Processing: US\$22.96/t ore milled
- / G&A US\$4.99/t ore milled
- / Total unit operating costs US\$55.45/t ore milled
- / LOM total operating costs US\$797.6 million
- / Excludes financing and corporate overhead costs

### 19.1.5 TAXATION AND ROYALTIES

- / Royalties: The current production zones as well as any in the 2024 LOM are not subject to an NSR or royalty to a third party / previous landowner.
- / Income tax is payable to the Federal Government of Canada, pursuant to the Income Tax Act (Canada). The applicable Federal income tax rate is 15% of taxable income.
- / Income tax is payable to the Province of Québec at a tax rate of 11.5% of taxable income.
- / No income taxes are payable until 2031 as Hecla uses its current tax pools and net operating loss carry forwards. Beginning in 2031, the effective tax rate used is 26.5% (combined federal and provincial).
- / Québec Mining Tax base rate is 16%.

270  
270

## 19.2 CASH FLOW ANALYSIS

RESPEC has reviewed and accepts Hecla's cash flow model as discussed in this section.

The Casa Berardi economics have been evaluated using the discounted cash flow method by considering annual processed tonnages and grade of ore. The associated process recovery, metal prices, operating costs, refining and transportation charges, and sustaining capital expenditures were also considered.

The full annual cash flow model is presented in Table 19-1 in US dollars with no allowance for inflation, show a pre-tax and after-tax NPV, using a 5% discount rate, of \$428 million and \$356 million, respectively. RESPEC is of the opinion that a 5% discount/hurdle rate for after-tax cash flow discounting of long lived precious/base metal operations in a politically stable region is reasonable and appropriate and commonly used. For this cash flow analysis, the internal rate of return (IRR) and payback are not applicable as there is no negative initial cash flow (no initial investment to be recovered) since Casa Berardi has been in operation for a number of years.

271  
271

Table STYLEREF 1 \s 19-. Annual Cash Flow Model

		Cash Flow Summary														
		Hecla Mining Company - Casa Berardi Mine														
		2024	2025	2026	2027	2028	2029	2030	2031	2032	2033	2034	2035	2036	2037	
	UNITS	TOTAL/AVERAGE	Year 1	Year 2	Year 3	Year 4	Year 5	Year 6	Year 7	Year 8	Year 9	Year 10	Year 11	Year 12	Year 13	Year 14
<b>Open Pit</b>																
Operating Days	days		366	365	365	365	366	365	365	365	366	365	365	366	366	78
Tonnes milled per day	tonnes / day		3,008	3,562	3,562	206	-	-	1,048	4,384	4,372	4,384	4,384	4,384	4,372	5,304
Tonnes moved per day	tonnes / day		65,500	27,182	380	-	26,645	53,000	84,000	86,500	86,500	86,500	77,162	20,846	13,048	56,821
Production	'000 tonnes	14,117	1,178	2,422	121	-	-	-	849	1,735	1,610	1,402	1,254	1,600	1,605	343
Au	g/t	2.72	1.79	1.81	1.87	-	-	-	2.87	3.22	3.21	2.96	3.11	3.12	2.88	2.51
Ag	g/t	-	-	-	-	-	-	-	-	-	-	-	-	-	-	-
Waste	'000 tonnes	219,454	22,795	7,500	18	-	9,752	19,345	29,811	29,838	30,049	30,171	26,910	6,009	3,171	4,086
Total Moved	'000 tonnes	233,571	23,973	9,921	139	-	9,752	19,345	30,660	31,572	31,659	31,572	28,164	7,609	4,776	4,429
Stripping Ratio	w.o	15.55	19.36	3.10	0.15	-	-	-	35.10	17.20	18.67	21.52	21.46	3.76	1.98	11.93
<b>Underground</b>																
Operating Days	days	180	180	-	-	-	-	-	-	-	-	-	-	-	-	-
Tonnes milled per day	tonnes / day	1,162	1,162	-	-	-	-	-	-	-	-	-	-	-	-	-
Production	'000 tonnes	209	209	-	-	-	-	-	-	-	-	-	-	-	-	-
Au	g/t	4.84	4.84	-	-	-	-	-	-	-	-	-	-	-	-	-
Ag	g/t	-	-	-	-	-	-	-	-	-	-	-	-	-	-	-
Waste	'000 tonnes	-	-	-	-	-	-	-	-	-	-	-	-	-	-	-
Total Moved	'000 tonnes	209	209	-	-	-	-	-	-	-	-	-	-	-	-	-
<b>Stockpile</b>																
Opening																
Tonnes	'000 tonnes		56	133,093	1,254,747	75,348	-	-	-	466,745	601,191	610,803	412,527	66,393	66,393	70,785
Au Grade	g/t		1.62	2.13	1.86	1.85	-	-	-	2.64	2.76	2.79	2.78	2.74	2.74	2.74
Ag Grade	g/t		-	-	-	-	-	-	-	-	-	-	-	-	-	-
Addition																
Tonnes	'000 tonnes		200	1,139,042	10,309	-	-	-	535,795	194,074	9,612	4,371	82,606	0	4,392	-
Au Grade	g/t		2.13	1.83	1.43	-	-	-	2.64	3.05	4.40	1.68	2.73	3.74	2.76	-
Ag Grade	g/t		-	-	-	-	-	-	-	-	-	-	-	-	-	-
Deduction																
Tonnes	'000 tonnes		123	17,389	1,189,708	75,348	-	-	69,050	59,628	-	202,647	428,740	-	-	70,785
Au Grade	g/t		1.89	2.13	1.86	1.86	-	-	2.64	2.76	-	2.78	2.78	-	-	2.71
Ag Grade	g/t		-	-	-	-	-	-	-	-	-	-	-	-	-	-
Closing																
Tonnes	'000 tonnes		133	1,254,747	75,348	-	-	-	466,745	601,191	610,803	412,527	66,393	66,393	70,785	-
Au Grade	g/t		2.13	1.86	1.85	-	-	-	2.64	2.76	2.79	2.78	2.74	2.74	2.74	-
Ag Grade	g/t		-	-	-	-	-	-	-	-	-	-	-	-	-	-

272  
272

Cash Flow Summary																
Hecla Mining Company - Casa Berardi Mine																
		2024	2025	2026	2027	2028	2029	2030	2031	2032	2033	2034	2035	2036	2037	
	UNITS	TOTAL/AVERAGE	Year 1	Year 2	Year 3	Year 4	Year 5	Year 6	Year 7	Year 8	Year 9	Year 10	Year 11	Year 12	Year 13	Year 14
<b>PROCESSING</b>																
Mill Feed	'000 tonnes	14,383	13,10	13,00	13,00	75	-	-	383	1,600	1,600	1,600	1,600	1,600	1,600	413
Au	g/t	2.75	2.24	1.79	1.86	1.86	-	-	3.14	3.22	3.21	2.94	3.04	3.12	2.88	2.54
Ag	g/t	1.05	0.51	0.23	4.81	-	-	-	0.34	0.71	0.76	0.81	0.93	0.75	0.69	0.74
Contained Au	oz	1,270,392	94,256	74,765	77,801	4,499	-	-	38,634	165,554	164,914	151,259	156,302	160,319	148,295	33,796
Contained Ag	oz	304,881	22,621	17,943	18,671	1,080	-	-	9,272	39,731	39,578	36,301	37,511	38,475	35,589	8,111
Net Recovery																
Au	%	81.5%	88.6%	88.6%	88.8%	88.8%	-	-	83.1%	83.3%	83.3%	81.8%	77.6%	76.3%	75.7%	76.8%
Ag	%	81.5%	88.6%	88.6%	88.8%	88.8%	-	-	83.1%	83.3%	83.3%	81.8%	77.6%	76.3%	75.7%	76.8%
<b>Total Recovered</b>																
Au	oz	<b>1,035,709</b>	<b>83,490</b>	<b>66,275</b>	<b>69,101</b>	<b>3,995</b>	-	-	<b>32,088</b>	<b>137,945</b>	<b>137,335</b>	<b>123,711</b>	<b>121,236</b>	<b>122,310</b>	<b>112,252</b>	<b>25,971</b>
Ag	oz	<b>248,560</b>	<b>20,037</b>	<b>15,905</b>	<b>16,584</b>	<b>959</b>	-	-	<b>7,701</b>	<b>33,105</b>	<b>32,959</b>	<b>29,689</b>	<b>29,095</b>	<b>29,353</b>	<b>26,939</b>	<b>6,233</b>
<b>REVENUE</b>																
<b>Metal Prices</b>	<b>Input Units</b>															
Au	US\$/oz Au	\$ 1,950	\$ 1,950	\$ 1,950	\$ 1,950	\$ 1,950	\$ 1,950	\$ 1,950	\$ 1,950	\$ 1,950	\$ 1,950	\$ 1,950	\$ 1,950	\$ 1,950	\$ 1,950	\$ 1,950
Ag	US\$/oz Au	\$ 22	\$ 22	\$ 22	\$ 22	\$ 22	\$ 22	\$ 22	\$ 22	\$ 22	\$ 22	\$ 22	\$ 22	\$ 22	\$ 22	\$ 22
Exchange Rate	US\$ 1.00 = X CS	1.35	1.35	1.35	1.35	1.35	1.35	1.35	1.35	1.35	1.35	1.35	1.35	1.35	1.35	1.35
Au Payable Percentage		99.9%	99.9%	99.9%	99.9%	99.9%	99.9%	99.9%	99.9%	99.9%	99.9%	99.9%	99.9%	99.9%	99.9%	99.9%
Ag Payable Percentage		99.0%	99.0%	99.0%	99.0%	99.0%	99.0%	99.0%	99.0%	99.0%	99.0%	99.0%	99.0%	99.0%	99.0%	99.0%
Au Gms Revenue	US\$ '000	\$ 2,017,613	\$ 162,642	\$ 129,106	\$ 134,613	\$ 7,783	\$ -	\$ -	\$ 62,508	\$ 268,724	\$ 267,535	\$ 240,995	\$ 236,173	\$ 238,267	\$ 218,673	\$ 50,593
Ag Gms Revenue	US\$ '000	\$ 5,414	\$ 436	\$ 346	\$ 361	\$ 21	\$ -	\$ -	\$ 168	\$ 721	\$ 718	\$ 647	\$ 634	\$ 639	\$ 587	\$ 136
<b>Total Gross Revenue</b>	<b>US\$ '000</b>	<b>\$ 2,023,027</b>	<b>\$ 163,079</b>	<b>\$ 129,453</b>	<b>\$ 134,974</b>	<b>\$ 7,804</b>	<b>\$ -</b>	<b>\$ -</b>	<b>\$ 62,676</b>	<b>\$ 269,445</b>	<b>\$ 268,253</b>	<b>\$ 241,642</b>	<b>\$ 236,807</b>	<b>\$ 238,906</b>	<b>\$ 219,259</b>	<b>\$ 50,729</b>
Total Charges	US\$ '000	\$ 4,220	\$ 340	\$ 270	\$ 282	\$ 16	\$ -	\$ -	\$ 131	\$ 562	\$ 504	\$ 494	\$ 498	\$ 457	\$ 106	
Net Smelter Return	US\$ '000	\$ 2,018,807	\$ 162,739	\$ 129,183	\$ 134,692	\$ 7,787	\$ -	\$ -	\$ 62,545	\$ 268,883	\$ 267,693	\$ 241,138	\$ 236,313	\$ 238,408	\$ 218,802	\$ 50,623
Royalty NSR	US\$ '000	\$ -	\$ -	\$ -	\$ -	\$ -	\$ -	\$ -	\$ -	\$ -	\$ -	\$ -	\$ -	\$ -	\$ -	\$ -
<b>Net Revenue</b>	<b>US\$ '000</b>	<b>\$ 2,018,807</b>	<b>\$ 162,739</b>	<b>\$ 129,183</b>	<b>\$ 134,692</b>	<b>\$ 7,787</b>	<b>\$ -</b>	<b>\$ -</b>	<b>\$ 62,545</b>	<b>\$ 268,883</b>	<b>\$ 267,693</b>	<b>\$ 241,138</b>	<b>\$ 236,313</b>	<b>\$ 238,408</b>	<b>\$ 218,802</b>	<b>\$ 50,623</b>

273  
273

**Cash Flow Summary**

**Hecla Mining Company - Casa Berardi Mine**

		2024		2025		2026		2027		2028		2029		2030		2031		2032		2033		2034		2035		2036		2037	
UNITS	TOTAL / AVERAGE	Year 1	Year 2	Year 3	Year 4	Year 5	Year 6	Year 7	Year 8	Year 9	Year 10	Year 11	Year 12	Year 13	Year 14														
<b>OPERATING COST</b>																													
Mining (Open Pit)	US\$/t ore mined	\$ 26.45	\$ 37.85	\$ 9.10	\$ 4.03	\$ -	\$ -	\$ -	\$ 30.18	\$ 27.46	\$ 22.96	\$ 23.90	\$ 83.35	\$ 17.65	\$ 11.05	\$ 35.24													
Mining (Underground)	US\$/t ore mined	\$ 106.23	\$ 106.23	\$ -	\$ -	\$ -	\$ -	\$ -	\$ -	\$ -	\$ -	\$ -	\$ -	\$ -	\$ -	\$ -	\$ -	\$ -	\$ -	\$ -	\$ -	\$ -	\$ -	\$ -	\$ -	\$ -	\$ -	\$ -	
Processing	US\$/t milled	\$ 22.96	\$ 22.96	\$ 22.96	\$ 22.96	\$ 22.96	\$ -	\$ -	\$ 22.96	\$ 22.96	\$ 22.96	\$ 22.96	\$ 22.96	\$ 22.96	\$ 22.96	\$ 22.96	\$ 22.96	\$ 22.96	\$ 22.96	\$ 22.96	\$ 22.96	\$ 22.96	\$ 22.96	\$ 22.96	\$ 22.96	\$ 22.96	\$ 22.96	\$ 22.96	
G&A	US\$/t milled	\$ 4.99	\$ 14.59	\$ 12.76	\$ 2.39	\$ 37.36	\$ -	\$ -	\$ 5.81	\$ 2.22	\$ 2.22	\$ 2.22	\$ 2.22	\$ 2.22	\$ 2.22	\$ 2.22	\$ 2.22	\$ 2.22	\$ 2.22	\$ 2.22	\$ 2.22	\$ 2.22	\$ 2.22	\$ 2.22	\$ 2.22	\$ 2.22	\$ 2.22	\$ 2.15	
<b>Total Unit Operating Cost</b>	<b>US\$/t milled</b>	<b>\$ 55.45</b>	<b>\$ 88.53</b>	<b>\$ 52.68</b>	<b>\$ 25.73</b>	<b>\$ 60.32</b>	<b>\$ -</b>	<b>\$ -</b>	<b>\$ 95.77</b>	<b>\$ 54.95</b>	<b>\$ 48.28</b>	<b>\$ 46.12</b>	<b>\$ 90.50</b>	<b>\$ 42.83</b>	<b>\$ 36.26</b>	<b>\$ 54.32</b>													
Mining (Open Pit)	US\$ '000	\$ 373,389	\$ 44,575	\$ 22,049	\$ 486	\$ -	\$ -	\$ -	\$ 25,634	\$ 47,627	\$ 36,959	\$ 33,503	\$ 104,520	\$ 28,237	\$ 17,723	\$ 12,075													
Mining (Underground)	US\$ '000	\$ 22,222	\$ 22,222	\$ -	\$ -	\$ -	\$ -	\$ -	\$ -	\$ -	\$ -	\$ -	\$ -	\$ -	\$ -	\$ -													
Processing	US\$ '000	\$ 330,271	\$ 30,086	\$ 29,855	\$ 29,855	\$ 1,730	\$ -	\$ -	\$ 8,786	\$ 36,744	\$ 36,744	\$ 36,744	\$ 36,744	\$ 36,744	\$ 36,744	\$ 36,744	\$ 36,744	\$ 36,744	\$ 36,744	\$ 36,744	\$ 36,744	\$ 36,744	\$ 36,744	\$ 36,744	\$ 36,744	\$ 36,744	\$ 36,744	\$ 9,493	
G&A	US\$ '000	\$ 71,704	\$ 19,111	\$ 16,593	\$ 3,111	\$ 2,815	\$ 2,815	\$ 2,815	\$ 2,222	\$ 3,556	\$ 3,556	\$ 3,556	\$ 3,556	\$ 3,556	\$ 3,556	\$ 3,556	\$ 3,556	\$ 3,556	\$ 3,556	\$ 3,556	\$ 3,556	\$ 3,556	\$ 3,556	\$ 3,556	\$ 3,556	\$ 3,556	\$ 3,556	\$ 889	
<b>Total Operating Cost</b>	<b>US\$ '000</b>	<b>\$ 797,586</b>	<b>\$ 115,995</b>	<b>\$ 68,497</b>	<b>\$ 33,452</b>	<b>\$ 4,545</b>	<b>\$ 2,815</b>	<b>\$ 2,815</b>	<b>\$ 36,642</b>	<b>\$ 87,927</b>	<b>\$ 77,259</b>	<b>\$ 73,803</b>	<b>\$ 144,820</b>	<b>\$ 68,537</b>	<b>\$ 58,023</b>	<b>\$ 22,457</b>													
<b>Operating Cashflow</b>	<b>US\$ '000</b>	<b>\$ 1,221,221</b>	<b>\$ 46,744</b>	<b>\$ 60,686</b>	<b>\$ 101,240</b>	<b>\$ 3,242</b>	<b>\$ (2,815)</b>	<b>\$ (2,815)</b>	<b>\$ 25,903</b>	<b>\$ 180,957</b>	<b>\$ 190,434</b>	<b>\$ 167,335</b>	<b>\$ 91,493</b>	<b>\$ 169,871</b>	<b>\$ 160,779</b>	<b>\$ 28,166</b>													
<b>CAPITAL COST</b>																													
Operating	US\$ '000	\$ 498,428	\$ 61,045	\$ 34,934	\$ 16,541	\$ 9,786	\$ 31,050	\$ 72,270	\$ 71,034	\$ 59,811	\$ 63,596	\$ 67,816	\$ 3,515	\$ 3,515	\$ 3,515	\$ -													
Salvage Value	US\$ '000	\$ (19,736)	\$ -	\$ -	\$ -	\$ -	\$ -	\$ -	\$ -	\$ -	\$ -	\$ -	\$ -	\$ -	\$ -	\$ (19,736)													
Reclamation and closure	US\$ '000	\$ 21,561	\$ -	\$ -	\$ -	\$ -	\$ -	\$ -	\$ -	\$ -	\$ -	\$ -	\$ -	\$ -	\$ -	\$ 21,561													
<b>Total Capital Cost</b>	<b>US\$ '000</b>	<b>\$ 500,253</b>	<b>\$ 61,045</b>	<b>\$ 34,934</b>	<b>\$ 16,541</b>	<b>\$ 9,786</b>	<b>\$ 31,050</b>	<b>\$ 72,270</b>	<b>\$ 71,034</b>	<b>\$ 59,811</b>	<b>\$ 63,596</b>	<b>\$ 67,816</b>	<b>\$ 3,515</b>	<b>\$ 3,515</b>	<b>\$ 3,515</b>	<b>\$ 1,825</b>													
<b>CASH FLOW</b>																													
Net Pre-Tax Cashflow	US\$ '000	\$ 720,968	\$ (14,301)	\$ 25,752	\$ 84,700	\$ (6,544)	\$ (33,865)	\$ (75,085)	\$ (45,130)	\$ 121,145	\$ 126,838	\$ 99,518	\$ 87,978	\$ 166,356	\$ 157,264	\$ 26,341													
Cumulative Pre-Tax Cashflow	US\$ '000	\$ -	\$ (14,301)	\$ 11,452	\$ 96,151	\$ 89,608	\$ 55,743	\$ (19,342)	\$ (64,473)	\$ 56,672	\$ 183,511	\$ 283,029	\$ 371,007	\$ 537,363	\$ 694,627	\$ 720,968													
Quebec Mining Tax	US\$ '000	\$ (43,844)	\$ (3,389)	\$ (2,003)	\$ (2,162)	\$ (38)	\$ -	\$ -	\$ (485)	\$ (7,318)	\$ (7,288)	\$ (6,242)	\$ (6,064)	\$ -	\$ (8,469)	\$ (386)													
Federal & Provincial Income Taxes	US\$ '000	\$ (75,044)	\$ -	\$ -	\$ -	\$ -	\$ -	\$ -	\$ (6,310)	\$ (13,348)	\$ (10,540)	\$ (0)	\$ (20,665)	\$ (24,180)	\$ -														
After-Tax Cashflow	US\$ '000	\$ 602,080	\$ (17,689)	\$ 23,749	\$ 82,537	\$ (6,581)	\$ (33,865)	\$ (75,085)	\$ (45,616)	\$ 107,517	\$ 106,202	\$ 82,736	\$ 81,914	\$ 145,690	\$ 124,614	\$ 25,955													
Cumulative After-Tax Cashflow	US\$ '000	\$ -	\$ (17,689)	\$ 6,060	\$ 88,598	\$ 82,016	\$ 48,151	\$ (26,934)	\$ (72,549)	\$ 34,968	\$ 141,170	\$ 223,906	\$ 305,820	\$ 451,511	\$ 576,125	\$ 602,080													
<b>PROJECT ECONOMICS</b>																													
Pre-tax NPV at 5% discounting	USDS '000	\$ 428,514																											
After-Tax NPV at 5% discounting	USDS '000	\$ 355,835																											

RESPEC's economic analysis confirmed that the Casa Berardi Mineral Reserves are economically viable at the assumed metal price forecast. The undiscounted pre-tax cash flow is US\$721 million, and the undiscounted after-tax cash flow is US\$602 million. The pre-tax NPV at a 5% base discount rate is US\$429 million and the after-tax NPV at a 5% base discount is US\$356 million.

### 19.3 SENSITIVITY ANALYSIS

Project risks can be identified in both economic and non-economic terms. Key economic risks were examined by running cash flow sensitivities on after-tax NPV at a 5% discount rate. The following parameters were examined:

- / Gold metal price
- / US\$/C\$ Exchange Rate
- / Operating costs
- / Capital costs (Sustaining, salvage, and closure)

For the case that includes mine equipment capital leases, after-tax sensitivities have been calculated for -20% to +20%. The sensitivities are presented in Table 19-2.

275  
275

Table STYLEREF 1 \s 19-. Sensitivity Analysis Summary

Variance From Base Case	Metal Prices	NPV at 5%
	(US\$/oz Au)	(US\$ M)
-20%	1560	129
-10%	1755	248
0%	1950	356
10%	2145	459
20%	2340	562
Variance From Base Case	Exchange Rate	NPV at 5%
	US\$/C\$	(US\$ M)
-20%	1.08	103
-10%	1.22	223
0%	1.35	356
10%	1.49	505
20%	1.62	674
Variance From Base Case	Operating Costs	NPV at 5%
	(US\$/t)	(US\$ M)
-20%	44.36	434
-10%	49.91	395
0%	55.45	356
10%	61.00	314
20%	66.55	272
Variance From Base Case	Capital Costs	NPV at 5%
	(US\$ 000)	(US\$ M)
-20%	400.2	430
-10%	450.2	393
0%	500.3	356
10%	550.3	319
20%	600.3	282

A comparison of results for the various sensitivity cases using after-tax NPV at a 5% discount rate are presented in Figure 19-1.

Figure STYLEREF 1 \s 19-. After-tax NPV at 5% Sensitivity Analysis

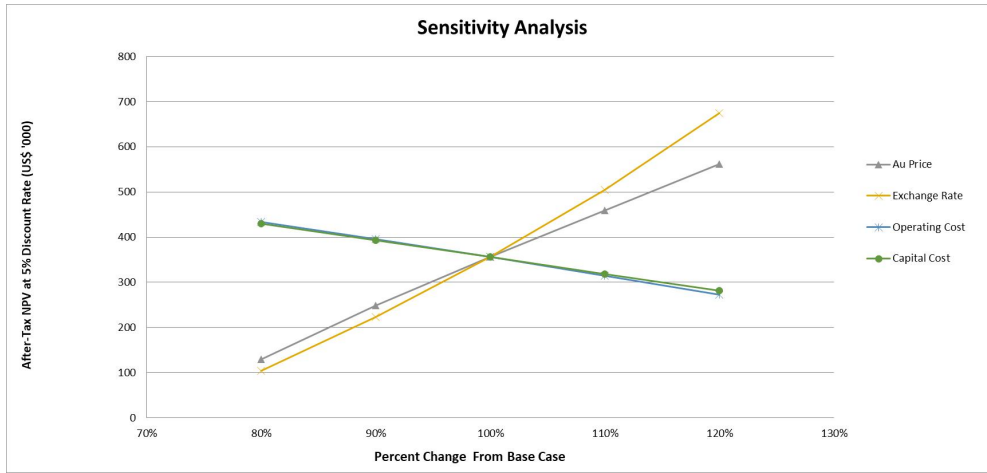

The Mine is most sensitive to changes in metal prices and US\$/C\$ exchange rate followed by operating costs and capital costs.

277  
277

## 20.0 ADJACENT PROPERTIES

Hecla controls a 37km strike length of favorable geology for gold mineralization along the Casa Berardi Fault. There are no significant gold deposits located immediately adjacent to the Property's boundaries.

## 21.0 OTHER RELEVANT DATA AND INFORMATION

There is no other relevant data or information.

## 22.0 INTERPRETATION AND CONCLUSIONS

### 22.1 GEOLOGY AND MINERAL RESOURCES

#### 22.1.1 GEOLOGY, MINERALIZATION AND DEPOSIT TYPES

The Casa Berardi Property is located in the northern part of the Abitibi Subprovince, within the Superior Province of the Archean core of the Canadian Shield. The regional geology is characterized by generally east-west assemblages of isoclinally folded and variably foliated and metamorphosed mafic volcanic rocks, flysch-type sedimentary iron formations, graphitic mudrocks, and a large granodioritic to granitic batholith. Structurally, the Property is within the Casa Berardi Break, a 15km wide corridor of strain that can be traced over 200km.

Three principal styles of mineralization have been recognized at Casa Berardi with gold occurring in: 1) quartz veins, 2) stockworks, and 3) banded iron formation. The mineralized zones are closely associated with the Casa Berardi Fault, which strikes east-west, dips 80° to the south, and was active along a disconformity between Archean volcanic and sedimentary rocks. The grade of gold mineralization associated with veins generally increases with increasing complexity, and contains only 1% to 3% sulfides, predominately arsenopyrite (the primary gold-bearing sulfide) and pyrite. Stockworks and gold-bearing banded iron formation generally contain lower grades. The Casa Berardi deposit can be classified as an Archean-age, sedimentary-hosted lode-gold deposit.

#### 22.1.2 ADEQUACY OF DATA USED IN ESTIMATING THE PROJECT MINERAL RESOURCES

Compilation and subsequent verification of the Casa Berardi database has been performed by Hecla personnel since 2014. Hecla staff compiles and loads all drill-hole and other relevant data used for geologic and mineral envelope modeling. Prior to importing sample assay results, the Hecla geologists evaluate the QA/QC data for possible blank

278  
278

or CRM failures. All assays within a given part of the sample batches associated with the failures are rerun if the intervals are mineralized, and the re-assays used in the database if warranted. All data undergoes a verification process, after which any issues found are corrected, and a final database is produced.

During the site visit in September 2023, RESPEC observed the geology of the Casa Berardi deposit and confirmed the presence of alteration and quartz-veining that is conducive to gold mineralization. Mined versus modeled reconciliations, which were generally reasonable, were reviewed. RESPEC reviewed Hecla's process for compiling collar, down-hole survey, and assay drill-hole data, and the verification of that data once it is entered.

To further evaluate Hecla's database compilation and verification process, RESPEC conducted an audit of all 2021, 2022 and 2023 assay data. Only 20 discrepancies in 85,903 assay records were found, yielding an acceptable 0.023% failure rate. Hecla's productive mining history using models that relied on pre-2021 data compilations and positive mined versus modeled reconciliations provide an additional level of confidence in Hecla's assay databases.

RESPEC is satisfied that the data compilation and verification programs performed by Hecla on the Casa Berardi project drill-hole data adequately ensures that the data contained in the resulting database is sufficiently accurate. Given Hecla's database validation process, RESPEC's verification of all 2021, 2022 and 2023 assay data, and the fact that Hecla has been modeling and mining at Casa Berardi using data compiled and verified in a similar manner for ten years, the drill-hole database is considered to be sufficient for use in geological and mineral domain modeling, Mineral Resource and Mineral Reserve estimation, and mine planning.

### 22.1.3 MINERAL RESOURCES

Measured and Indicated Resources, effective December 31, 2023, consist of a total of 4.12Mt with an average gold grade of 6.39g Au/t containing 0.84Moz Au. Inferred Mineral Resources total 2.09Mt at 5.89g/t Au for 0.40Moz Au. The open pit resources are constrained within the designed pit while underground material was constrained by stope optimizations, reflecting the potential for underground and open pit mining and mill processing of the present Casa Berardi deposits.

Hecla considered density and quality of drill-hole data, the established continuity of the auriferous zones, and production experience in classification of the Casa Berardi gold Mineral Resources in the open pit and underground block models (Figure 1-1). Classification was applied based on the average distance of a given block centroid to drill-hole composites used to estimate the block grade, the proximity to mine workings, and the location within modeled mineral envelopes. RESPEC has evaluated Hecla's classification for the Casa Berardi Mineral Resources, and concludes the following:

- / Hecla's application of mean distances used to estimate a given block grade is a reasonable approach to classifying resources. Average and closest distances (isotropic and anisotropic) of composites relative to blocks is commonly used in the mining industry for resource classification, and satisfies S-K 1300 requirements;
- / It is reasonable to upgrade resource classification from Indicated to Inferred for blocks in close proximity to mined mineralization;
- / Hecla's data compilation and verification process generally ensures that the assay and other drill data that form the basis for mineral envelope modeling and resource estimation are generally reliable. RESPEC also verified

279  
279

gold assays in Hecla's database against certificates for 2021 to 2023, and found only 20 errors in 85,903 assay records. The data verification justifies the classification of material as Indicated.

- / All or parts of drill-hole assays determined to be unreliable, due to QA/QC failures or unverifiable/conflicting assays in historical holes, are generally removed or replaced in the database. This adds confidence in the drill-hole database used for resource modeling and justifies classification of some material as Indicated.
- / Hecla's geologic and mineral envelope models reasonably guide and constrain gold estimation, which increases confidence that the overall reported Mineral Resources.
- / The general production history and reasonable mined-versus-model reconciliation results validates past models and estimates, and justifies the continued classification of material as Measured and Indicated.

#### 22.1.4 EXPLORATION POTENTIAL

RESPEC believes that exploration potential remains on the Property along strike and at depth of known gold mineralization along the Casa Berardi Fault, both within and outside the current mine areas. Geophysics and drilling will be important exploration tools for making new discoveries at Casa Berardi, particularly for gold mineralization concealed by glacial till and other post-mineral overburden material outside the mine areas.

## 22.2 MINING AND MINERAL RESERVES

- / Mineral Reserves have been classified in accordance with the definitions for Mineral Reserves in S-K 1300. Mineral Reserves as of December 31, 2023 total 14.38Mt grading 2.75g/t Au containing 1.27Moz Au.
- / Measured and Indicated Mineral Resources were converted to Proven and Probable Mineral Reserves, respectively. Inferred Mineral Resources were not converted to Mineral Reserves.
- / The mining methods at Casa Berardi are well established with many years of operating experience, providing the necessary expertise to, safely and economically, extract the Mineral Reserves.
- / Both transverse and longitudinal longhole stoping methods are employed underground. Challenging ground conditions require the use of various types of backfill to provide the necessary support.
- / Underground mining will come from the West Mine in 2024 as the East mine was abandoned in 2023 to allow for backfilling the adjoining EMCP pit. Mining from various open pits on surface represents the bulk of the Mineral Reserves to be mined, accounting for approximately 98.5% of the Casa Berardi Mineral Reserves.
- / The current LOM period is estimated to be 14 years ending in 2037. Underground Mineral Reserves totaling 209kt will be mined during the first year while open pit Mineral Reserves totaling 14.2Mt will be mined over the entire LOM period.
- / The LOM plan considers a 30-month delay in mining to allow for the expected permitting timeline.

## 22.3 MINERAL PROCESSING

- / Metallurgical and production models have been developed from extensive baseline sampling and are further adjusted annually to account for process and metallurgical improvements and changes.
- / The test work performed on open pit material was used to estimate gold recovery, while operating data was used for underground material. Extensive test work has been performed by an external laboratory on future open pit

280  
280

material (West Mine Crown Pillar (WMCP) and Principal). WMCP test results were used to inform the long-term mine plan.

- / Test work programs, both internal and external, continue to be performed to support current operations and potential improvements.
- / The current process facilities are appropriate for the mineralization material extracted from the mine. The flowsheet, equipment, and infrastructure are expected to support the current LOM plan.

## 22.4 INFRASTRUCTURE

- / Hecla is currently mining at Casa Berardi and has both open pit and underground infrastructure, as well as a mill. Hecla plans to develop three additional open pits (Principal, WMCP, and F134) and associated waste rock storage facilities, and other surface infrastructure for future mine operations.
- / With the increase of pit production, an expanded maintenance facility will be required. A capital allowance is included in cashflow model.

## 22.5 ENVIRONMENT

- / Hecla has sufficiently assessed the environmental impact of the operation, and subsequent closure and restoration requirements such that Mineral Resources and Mineral Reserves can be declared, and the mine plan deemed appropriate and achievable. Closure provisions are appropriately considered, and monitoring programs are in place.
- / Hecla has developed a community relations plan to identify and ensure an understanding of the needs of the surrounding communities and to determine appropriate programs for addressing those needs. Hecla appropriately monitors socio-economic trends, community perceptions, and mining impacts.
- / Current permits held by Hecla for the Property are sufficient to ensure that the planned surface and underground mining activities which will take place into 2026 are conducted in accordance with the local, provincial, and national regulatory frameworks.
- / Beyond 2026, the LOM plan includes the development of three additional open pits along with associated waste rock storage facilities and other infrastructure. This planned development may require an EIA to be performed at the Property. Hecla expects to submit a project notice to the Provincial MELCCFP in 2024 that describes the proposed development and proposed plan of operations. Hecla expects from the EIA process that all necessary permits will be obtained so that mining of the planned open pits can take place in accordance with local, provincial, and national regulatory frameworks.
- / There are currently no known environmental, permitting, or social/community risks that could impact the extraction of Mineral Resources or Mineral Reserves.

281  
281

## 23.0 RECOMMENDATIONS

It is normal that there are not many recommendations for mature operations like Casa Berardi. RESPEC offers the following recommendations by area.

### 23.1 GEOLOGY AND MINERAL RESOURCES

RESPEC makes the following recommendations regarding QA/QC procedures and evaluations:

- / Investigate the high bias in ALS pulp duplicate assays relative to the Labomine and Swastika lab original assays;
- / Discontinue external check assays for coarse reject material;
- / Implement procedures that will reduce CRM mislabeling or “swaps”;
- / Evaluate duplicate, CRM, blank and check assays independently for each lab;
- / Track CRM assay failures by lab for each standard, and document steps taken to follow up on the failures;
- / Evaluate duplicate data on plots that show individual sample pairs. Averages of data provides an overall measure of assay bias, but does not characterize assay variability, which is usually a function of natural heterogeneity of gold in the deposits. Individual plots also better characterizes bias; and
- / Investigate blank assay values that exceed a 5x detection limit, and particularly those that are at or above potential mining cutoff grades. Evaluate relative to preceding assay values to determine if contamination could be occurring from previously processed mineralized samples. Document follow-up process and results.

The primary issue noted in the resource models by RESPEC is significant grade and tonne smoothing, particularly in the open pit models. RESPEC believes the models could be improved by further confining and separating relatively low- and high-grade mineralization within the 1.0g/t Au and 4.0g/t Au envelopes currently in use. An immediate improvement could be realized in the open pit models by using both sets of wireframes, such that the higher-grade mineralization within the structural zone wireframes would be separated from the lower-grade mineralization between the 4.0g/t Au and the 1.0g/t Au envelopes.

The best method to minimize smoothing and more accurately represent grade distribution in a mineral estimate is to physically constrain the model with domains in proper geological context. Population distribution plots of all gold values provide a starting point for identification of the different assay populations that are likely characterized by specific lithologic, alteration and/or mineralogical characteristics. Modeling gold domains at grade breaks evident on plots of these types would limit grade smoothing to within related assay populations. Domain modeling while reviewing core and log data will help to determine the geological context of each grade population.

The primary recommendations to resource estimation made by RESPEC are:

- / Apply tighter constraints to Mineral Resource estimates with additional geologically defined mineral envelopes.
- / Increase drilling density for open pit deposits where mineralization is missed and therefore cannot be modeled because the current spacing is insufficient.

282  
282

- / Use the same block dimensions based on the SMU for all open pit block models.
- / Add mapping of pit faces and floors, and blasthole logs to Project database, and incorporate when updating geologic and mineral envelope models.
- / For classification, density of drilling could be applied directly to classification by adding the number of holes and/or composites used to estimate a given block grade to classification criteria in conjunction with distances to composites.

## 23.2 MINING AND MINERAL RESERVES

- / Review marginal underground Mineral Resources for extraction due to higher spot prices in the near term.
- / Continue to convert Mineral Resources to Mineral Reserves to extend the underground operation past 2024, and extend open pit mining where possible.
- / Investigate adding marginal underground Measured and Indicated Mineral Resources to the Mineral Reserves.
- / Since the existing cost model is based on contractor rates, an evaluation of a complete haulage model will provide a more comprehensive understanding of late-stage owner operator costs. It would be expected that mining operating costs could be lowered for future studies.

## 23.3 MINERAL PROCESSING

- / Continue to conduct additional metallurgical testing to better understand the processing of mineralization from the Principal and WMCP pits. This will aid in projecting metallurgical recoveries for these pits and will indicate any variability in gold recovery and grindability of the material.

283  
283

## 24.0 REFERENCES

- AACE International, 2012, Cost Estimate Classification System – As applied in the Mining and Mineral Processing Industries, AACE International Recommended Practice No. 47R-11, 17 p.
- Alcott, J. and Belem, T., 2019, Pastefill Optimization at Hecla Québec’s Casa Berardi Mine, (June 2019).
- Amec Foster Wheeler plc, 2013, Project TX 13 1287 03, Open Pit Overburden Slope Design Report East Half of Open Pit East Mine Casa Berardi Mine Abitibi Region, Québec, Dorval, Québec, prepared for Aurizon Mines Ltd. (November 2013).
- Assima, Gnouyaro P., 2017, Récupérations fosse 160,134 et EMCP, Reference T2211, prepared by COREM for Hecla Québec Inc. (December 2017).
- Azevedo, C., Jébrak, M., Genna, D., and Pinti, D.L., 2022, Evidence of gold related to Neoproterozoic alkaline magmatism in the Abitibi greenstone belt (Canada) from mineral parageneses and microscale trace element geochemistry on pyrite, *Ore Geology Reviews*, v. 1.
- Baril, Serge, 2017, Essais de sédimentation de solides à l’épaisseur de l’usine, prepared by SNF Canada Ltd. for Hecla Québec Inc. (April 2017).
- BBA Inc., 2009, Updated Mining Pre-Feasibility Study East Mine Crown Pillar Project, La Sarre, Québec prepared for Aurizon Mines Ltd. (February 2009)
- BBA Inc., 2011, Technical Report on the Pre-Feasibility Study on the Principal Zone Open Pit Project La Sarre, Québec, prepared for Aurizon Mines Ltd. (February 2011)
- BBA Inc., 2017a, Conceptual Design Mixed Waste Facility (MWF) – East Pit, La Sarre, Québec, prepared for Hecla Québec Inc. (April 2017).
- BBA Inc., 2017b, East Mine Crown Pillar Life-of-Mine Planning Update, La Sarre, Québec, prepared for Hecla Québec Inc. (March 2017).
- Blue Coast Research Ltd., 2020, Casa Berardi 160 Pit Metallurgical Testwork Program, prepared for Hecla Mining Company (August 18, 2020).
- Blue Coast Research Ltd., 2020b, Casa Berardi West Mine Crown Pillar (WMCP) Metallurgical Testwork Program, prepared for Hecla Mining Company (December 23, 2020).
- Blue Coast Research Ltd., 2021a, Casa Berardi – Principal Pit Metallurgical Testwork, prepared for Hecla Mining Company (March 3, 2021).
- Blue Coast Research Ltd., 2021b, Casa Berardi – WMCP Flotation Metallurgical Testwork, prepared for Hecla Mining Company (May 13, 2021).

Blue Coast Research Ltd., 2022, Casa Berardi – WMCP Phase 2 Metallurgical Testwork, prepared for Hecla Mining Company (April 29, 2022).

Blue Coast Research Ltd., 2023, Casa Berardi – WMCP Extension, prepared for Hecla Mining Company (February 8, 2023).

Canmet, 1999, In Situ Ground Stress Determination at the Casa Berardi Mine, Report MMSL 90-011 (CR), prepared for Aurizon Ltd., (March 1999).

Clow, G.G., Cox, J.J., Hayden, A., Knapp, R., and Salmon, B., 2005 (October), Technical report on the Casa Berardi project, Quebec, Canada: NI 43-101 technical report prepared by Roscoe Postle Associates Inc., for Aurizon Mines Ltd., 241 p.

ConeTec, 2021, Presentation of Site Investigation Results, Casa Berardi Mine Pit 160, EMCP, Principal Pit, WMCP, WRD (April 29, 2021).

Dubé et al. 2007;

FLSmith & Co. A/S, 2014, Ore Variability Tests Performed on Seven Composite Samples from the Casa Berardi Mine, Project P14058AA, prepared for Hecla Québec Inc. (December 2014).

Geophysique Sigma Inc., 2020, Leve Electrique Complementaire 2020, Project C19734 (September 2020).

Golder Associates Inc., 2009, Revised Technical Update on Geotechnical Design Considerations and Recommendations for the Casa Berardi East Mine Dumps and Open Pit Slopes (Final), prepared for Aurizon Mines Ltd. (October 2009)

Golder Associates Inc., 2011, Slope Stability Analysis at Casa Berardi – Mine Principale, prepared for Aurizon Mines Ltd. (January 2011)

Golder Associates Inc., 2013, Geomechanics and Rock Slope Stability Analyses for Zone 160 Feasibility Study, prepared for Aurizon Mines Ltd. (August 2013)

Hecla Québec Inc., 2014, Plan de Restauration et de Fermeture (January 2014)

Hecla Québec Inc., 2015, Study for Re-Opening of the Casa Berardi, East Mine, Québec (January 2015).

Hecla Québec Inc., 2018, Design Pente EMCP Secteur du mur Nord, Evaluation de design de pente 3 :1 dans l'argile et positionnement de chemin de haulage en sommet de talus, La Sarre, Québec, (March 2018).

Hecla Québec Inc., 2019, Programme de Controle de Terrain Fosses et Haldes, Internal Report by Benjamin Gareau-Blais (October 2019).

Hecla Québec Inc., 2019, Technical Report for the Casa Berardi Mine, Northwestern Québec, Canada (April 1, 2019).

Hydro-Resources Inc., 2017, Etude hydrogologique Fosse EMCP, DossierPR16-102 (May 2017).

285  
285

Hydro-Resources Inc., 2020, Fosse 160 - Mise a Jour, Letter Report by Michael Verreault Dated October 9, 2020.

Hydro-Ressources Inc., 2018, Etude Hydrogéologique – Zone 160 Hecla rapport technique – dossier PR17-101, Lévis, Québec, prepared for Hecla Québec Inc. (October 2018).

Itasca Consulting Group Inc., 2020, Slope Stability and Hydrogeology Assessment for Zone 160 Open Pit at Casa Berardi, Reference No 2-4577-03:20R14, prepared for Hecla Québec Inc. (June 2020).

Lacasse, Simon, 2017, Test program to evaluate cyanide destruction options for the treatment of effluents from Casa Berardi Mine in Québec, prepared by Cyanco for Hecla Québec Inc. (August 2017).

Large et al., 2007

Lelièvre, Jean, 2006, Essais métallurgiques sur le minerai Casa Berardi, Reference PU-2006-10-262, prepared by Unité de recherche et de service en technologie minérale (URSTM) for Aurizon Mines Ltd. (November 2006).

Lelièvre, Jean, 2009, Essais métallurgiques sur les veines principales 24\_01, 25\_08\_02 et 25\_04 du gisement Casa Berardi, Reference PU-2008-09-410, prepared by Unité de recherche et de service en technologie minérale (URSTM) for Aurizon Mines Ltd. (January 2009).

Linnen, Robert, 2016, Summary of Recent Raman Work, prepared by the University of Western Ontario for Hecla Québec Inc. (June 2016).

Mine Development Associates (MDA), 2018a, Casa Berardi 160 and 134 Zones Open Pit Mining Study, prepared for Hecla Québec Inc. (February 2018).

Mine Development Associates (MDA), 2018b, East Mine Crown Pillar Expansion Open Pit Mining Study, prepared for Hecla Québec Inc. (August 2018).

Mine Development Associates (MDA), 2018c, Principal Deposit Open Pit Mining Study, prepared for Hecla Québec Inc. (September 2018 and amended February 2019).

Mine Development Associates (MDA), 2019, West Mine Crown Pillar Open Pit Mining Study, prepared for Hecla Québec Inc. (January 2019 and amended February 2019).

Monecke, T., Mercier-Langevin, P., and Dubé, B., 2017, eds., Archean base and precious metal deposits, southern Abitibi greenstone belt, Canada, Reviews in Economic Geology, v. 19.

Robert et al., 2005

Roscoe Postle Associates (RPA) Inc. and BBA Inc., 2011, Technical Report on the Casa Berardi Mine, Northwestern Québec, Canada, prepared for Aurizon Mines Ltd. (March 28, 2011).

Roscoe Postle Associates (RPA) Inc., 2005, Technical Report on the Casa Berardi Project, Québec, Canada, prepared for Aurizon Mines Ltd. (October 2005).

286  
286

Roscoe Postle Associates (RPA) Inc., 2014, Technical Report on the Mineral Resource and Mineral Reserve Estimates for the Casa Berardi Mine, Northwestern Québec, Canada, prepared for Hecla Québec Inc. (March 31, 2014).

Roscoe Postle Associates (RPA) Inc., BBA Inc., and InnovExplo, 2013, Technical Report on the Mineral Resource and Mineral Reserve Estimates for the Casa Berardi Mine, Northwestern Québec, Canada, prepared for Aurizon Mines Ltd. (March 31, 2013).

Scott Wilson Roscoe Postle Associates Inc., 2007a, Casa Berardi – Lower Inter Zone Mineral Resource Update, Internal report prepared for Aurizon Mines Ltd. (July 2007).

Scott Wilson Roscoe Postle Associates Inc., 2007b, December 2006 Mineral Resource and Mineral Reserve Audit, Internal report prepared for Aurizon Mines Ltd. (May 2007).

Scott Wilson Roscoe Postle Associates Inc., 2007c, Mise à Jour des Ressources de la Mine Est (Sous-Terre) – Rapport Préliminaire, Internal report prepared for Aurizon Mines Ltd. (December 2007).

Scott Wilson Roscoe Postle Associates Inc., 2008a, December 2007 Mineral Resource and Mineral Reserve Audit, Internal report prepared for Aurizon Mines Ltd. (April 2008).

Scott Wilson Roscoe Postle Associates Inc., 2008b, Mise à Jour des Ressources de la Mine Principale – Juillet 2008, Internal report prepared for Aurizon Mines Ltd. (July 2008).

Scott Wilson Roscoe Postle Associates Inc., 2008c, Whittle Analysis of the Principal Zone, Internal report prepared for Aurizon Mines Ltd. (September 2008).

Scott Wilson Roscoe Postle Associates Inc., 2009, Technical Report on the Casa Berardi Mine, Northwestern Québec, Canada, prepared for Aurizon Mines Ltd., (February 9, 2009).

Scott Wilson Roscoe Postle Associates Inc., 2010a, December 2009 Mineral Resource and Mineral Reserve Audit, Internal report prepared for Aurizon Mines Ltd. (February 2010).

Scott Wilson Roscoe Postle Associates Inc., 2010b, Principal Mine Resource Update. Internal report prepared for Aurizon Mines Ltd (October 2010).

Scott Wilson Roscoe Postle Associates Inc., 2010c, Principal Project Preliminary Whittle Runs, Internal report prepared for Aurizon Mines Ltd (August 2010).

Scott Wilson Roscoe Postle Associates Inc., 2010d, Technical Report on the Casa Berardi Mine, Northwestern Québec, Canada, prepared for Aurizon Mines Ltd.

Scott Wilson Roscoe Postle Associates Inc., 2011, 160 Zone (Casa Berardi) Preliminary Open Pit Optimization, Internal report prepared for Aurizon Mines Ltd (February 2011).

SGS Canada Inc., 2017, The Characterization of Samples from the Casa Berardi Mine, Project 16152-001, prepared for Hecla Québec Inc. (August 2017).

- SLR Consulting (Canada) Ltd., 2022, Technical Report Summary on the Casa Berardi Mine, Northwestern Québec, Canada S-K 1300 TRS, prepared for Hecla Mining Company (February 21, 2022).
- SRK Consulting (Canada) Inc., 2021a, Casa Berardi Supplemental Site Wide Hydrogeology Field Investigation Program, prepared for Hecla Québec Inc. (October 2021).
- SRK Consulting (Canada) Inc., 2021b, Phase 1: Conceptual Model and Gap Analysis Memo – Hydrogeology, prepared for Hecla Québec Inc. (March 5, 2021).
- SRK Consulting (Canada) Inc., 2021c, Principal Pit Groundwater Modelling for Passive Inflow Predictions, prepared for Hecla Québec Inc. (November 2021).
- SRK Consulting (Canada) Inc., 2021d, Casa Berardi – Bedrock Hydrogeology Field Investigation Program, Prepared for Hecla Québec Inc. (October 2021).
- SRK Consulting (Canada) Inc., 2021e, Phase 1: Conceptual Model and Gap Analysis Memo – Soil Geotechnical, prepared for Hecla Québec Inc. (March 5, 2021).
- SRK Consulting (Canada) Inc., 2021f, Casa Berardi Bedrock Hydrogeology Field Investigation Program (October 2021).
- SRK Consulting (Canada) Inc., 2021g, Phase 1: Conceptual Model and Gap Analysis Memo – Geomechanical and Structural Geology (March 5, 2021).
- SRK Consulting (Canada) Inc., 2021h, Phase 1: Conceptual Model and Gap Analysis Memo – Soil Geotechnical (March 5, 2021).
- Unité de recherche et de service en technologie minérale (URSTM), 2011, Caractérisation métallurgique et environnementale de 11 échantillons de minerais de la mine Casa Berardi, Reference PU-2011-01-581 prepared for Aurizon Mines Ltd. (August 2011).
- Unité de recherche et de service en technologie minérale (URSTM), 2012, Caractérisation métallurgique et environnementale de 18 zones de minerais de la mine Casa Berardi, Reference PU-2011-06-636, prepared for Aurizon Mines Ltd. (March 2012).
- Unité de recherche et de service en technologie minérale (URSTM), 2013a, Caractérisation de l'or réfractaire dans 13 rejets de Casa Berardi, Reference PU-2012-10-753, prepared for Hecla Québec Inc. (September 2013)
- Unité de recherche et de service en technologie minérale (URSTM), 2013b, Caractérisation métallurgique de 13 Échantillons Provenant des Zones 118 et 123, Rapport final PU- 2012-07-0731, prepared for Hecla Québec Inc. (January 2013).
- Unité de recherche et de service en technologie minérale (URSTM), 2015, Analyse minéralogique semi-quantitative par diffraction des rayons X, Reference PU-2015-07-1000, prepared for Hecla Québec Inc. (August 2015).

US Securities and Exchange Commission, 2018: Regulation S-K, Subpart 229.1300, Item 1300 Disclosure by Registrants Engaged in Mining Operations and Item 601 (b)(96) Technical Report Summary.

289  
289

RSI-M0206.22001

---

## 25.0 RELIANCE ON INFORMATION PROVIDED BY THE REGISTRANT

This TRS has been prepared by RESPEC for Hecla. The information, conclusions, opinions, and estimates contained herein are based on:

- / Information available to RESPEC at the time of preparation of this TRS,
- / Assumptions, conditions, and qualifications as set forth in this TRS, and
- / Data, reports, and other information supplied by Hecla and other third party sources.

RESPEC has not researched property title or mineral rights for Casa Berardi as we consider it reasonable to rely on the Hecla personnel at Casa Berardi responsible for maintaining this information.

RESPEC has relied on Hecla for guidance on applicable taxes, royalties, and other government levies or interests, applicable to revenue or income from the Property in the Executive Summary and Section 19.0 As the Property has been in operation for over 30 years, Hecla has considerable experience in this area.

RESPEC has taken all appropriate steps, in its professional opinion, to ensure that the above information from Hecla is sound.

Except for the purposes legislated under provincial securities laws, any use of this TRS by any third party is at that party's sole risk.

290  
290

## 26.0 DATE AND SIGNATURE PAGE

This report titled “Technical Report Summary on the Casa Berardi Mine, Northwestern Québec, Canada” with an effective date of December 31, 2023, was prepared and signed by:

Dated at Reno, NV  
February 15, 2023

**Signed RESPEC Company, LLC**  
RESPEC Company, LLC

Dated at Bothell, WA  
February 15, 2023

**Signed SLR Consulting US LLC**  
SLR Consulting US LLC

291  
291

RSI-M0206.22001

---

# APPENDIX A

## Claims Table

1-A  
1-A

# APPENDIX A: CLAIMS TABLE

## A.1 Claims Table

Project	Titleholder	Type of Title	Title No	NSR	Expiry Date (YYYYMMDD)	Area (ha)	Registration Date (YYYYMMDD)	Required Fees (C\$)	Required Work (C\$)	Excess Work (C\$)
Casa Berardi Mine	Hecla Québec Inc.	BM (Mining Lease)	1054	-	20241005	92.56	20201006	\$4,974.03	\$0.00	\$0.00
Casa Berardi Mine	Hecla Québec Inc.	CDC	1097901	-	20240509	55.85	20020911	\$73.25	\$2,500.00	\$461,119.67
Casa Berardi Mine	Hecla Québec Inc.	CDC	1097902	-	20240509	55.85	20020911	\$73.25	\$2,500.00	\$163,103.11
Casa Berardi Mine	Hecla Québec Inc.	CDC	1097903	-	20240509	55.85	20020911	\$73.25	\$2,500.00	\$3,819.94
Casa Berardi Mine	Hecla Québec Inc.	CDC	1097904	-	20240509	55.85	20020911	\$73.25	\$2,500.00	\$11,019.94
Casa Berardi Mine	Hecla Québec Inc.	CDC	1097905	-	20240509	55.85	20020911	\$73.25	\$2,500.00	\$13,560.17
Casa Berardi Mine	Hecla Québec Inc.	CDC	1097906	-	20240509	55.85	20020911	\$73.25	\$2,500.00	\$11,019.94
Casa Berardi Mine	Hecla Québec Inc.	CDC	1097930	-	20240509	55.84	20020911	\$73.25	\$2,500.00	\$250,023.64
Casa Berardi Mine	Hecla Québec Inc.	CDC	1097931	-	20240729	37.02	20020911	\$73.25	\$2,500.00	\$158,855.16

2-A  
2-A

Casa Berardi Mine	Hecla Québec Inc.	CDC	1097932	-	20240509	55.85	20020911	\$73.25	\$2,500.00	\$11,019.94
Casa Berardi Mine	Hecla Québec Inc.	CDC	1097957	-	20240509	55.83	20020911	\$73.25	\$2,500.00	\$11,673.42
Casa Berardi Mine	Hecla Québec Inc.	CDC	1097958	-	20240509	55.83	20020911	\$73.25	\$2,500.00	\$11,008.25
Casa Berardi Mine	Hecla Québec Inc.	CDC	1097959	-	20240509	55.83	20020911	\$73.25	\$2,500.00	\$149,197.80
Casa Berardi Mine	Hecla Québec Inc.	CDC	1097960	-	20240509	55.83	20020911	\$73.25	\$2,500.00	\$138,113.25
Casa Berardi Mine	Hecla Québec Inc.	CDC	1097961	-	20240509	55.83	20020911	\$73.25	\$2,500.00	\$125,685.18
Casa Berardi Mine	Hecla Québec Inc.	CDC	1097962	-	20240509	55.83	20020911	\$73.25	\$2,500.00	\$11,008.25
Casa Berardi Mine	Hecla Québec Inc.	CDC	1097963	-	20240509	55.83	20020911	\$73.25	\$2,500.00	\$11,008.25
Casa Berardi Mine	Hecla Québec Inc.	CDC	1097964	-	20240509	55.83	20020911	\$73.25	\$2,500.00	\$82,512.45
Casa Berardi Mine	Hecla Québec Inc.	CDC	1097965	-	20240729	43.25	20020911	\$73.25	\$2,500.00	\$60,042.12
Casa Berardi Mine	Hecla Québec Inc.	CDC	1097966	-	20240729	23.90	20020911	\$37.50	\$1,000.00	\$1,378,638.84
Casa	Hecla Québec Inc.	CDC	1097967	-	20240729	41.75	20020911	\$73.25	\$2,500.00	\$305,600.11

3-A  
3-A

Berardi Mine										
Casa Berardi Mine	Hecla Québec Inc.	CDC	1097968	-	20240509	55.84	20020911	\$73.25	\$2,500.00	\$11,014.09
Casa Berardi Mine	Hecla Québec Inc.	CDC	1097991	-	20240509	55.82	20020911	\$73.25	\$2,500.00	\$11,002.41
Casa Berardi Mine	Hecla Québec Inc.	CDC	1097992	-	20240509	55.82	20020911	\$73.25	\$2,500.00	\$11,002.41
Casa Berardi Mine	Hecla Québec Inc.	CDC	1097993	-	20240509	55.82	20020911	\$73.25	\$2,500.00	\$11,002.41
Casa Berardi Mine	Hecla Québec Inc.	CDC	1097994	-	20240509	55.82	20020911	\$73.25	\$2,500.00	\$11,002.41
Casa Berardi Mine	Hecla Québec Inc.	CDC	1097995	-	20240509	55.82	20020911	\$73.25	\$2,500.00	\$11,002.41
Casa Berardi Mine	Hecla Québec Inc.	CDC	1097996	-	20240509	55.82	20020911	\$73.25	\$2,500.00	\$11,002.41
Casa Berardi Mine	Hecla Québec Inc.	CDC	1097997	-	20240509	55.83	20020911	\$73.25	\$2,500.00	\$11,008.25
Casa Berardi Mine	Hecla Québec Inc.	CDC	1097998	-	20240509	55.83	20020911	\$73.25	\$2,500.00	\$11,008.25
Casa Berardi Mine	Hecla Québec Inc.	CDC	1097999	-	20240509	55.83	20020911	\$73.25	\$2,500.00	\$14,641.84
Casa Berardi Mine	Hecla Québec Inc.	CDC	1098000	-	20240509	55.83	20020911	\$73.25	\$2,500.00	\$11,008.25
Casa	Hecla Québec Inc.	CDC	1098001	-	20240509	55.83	20020911	\$73.25	\$2,500.00	\$11,008.25

4-A  
4-A

Berardi Mine										
Casa Berardi Mine	Hecla Québec Inc.	CDC	1098002	-	20240509	55.83	20020911	\$73.25	\$2,500.00	\$11,008.25
Casa Berardi Mine	Hecla Québec Inc.	CDC	1098041	-	20240509	55.86	20020911	\$73.25	\$2,500.00	\$23,697.41
Casa Berardi Mine	Hecla Québec Inc.	CDC	1098074	-	20240509	55.87	20020911	\$73.25	\$2,500.00	\$0.00
Casa Berardi Mine	Hecla Québec Inc.	CDC	1098085	-	20240509	55.86	20020911	\$73.25	\$2,500.00	\$0.00
Casa Berardi Mine	Hecla Québec Inc.	CDC	1098086	-	20240509	55.86	20020911	\$73.25	\$2,500.00	\$429.32
Casa Berardi Mine	Hecla Québec Inc.	CDC	1098087	-	20240509	55.86	20020911	\$73.25	\$2,500.00	\$21,188.88
Casa Berardi Mine	Hecla Québec Inc.	CDC	1098088	-	20240509	55.86	20020911	\$73.25	\$2,500.00	\$30,594.09
Casa Berardi Mine	Hecla Québec Inc.	CDC	1098089	-	20240509	55.86	20020911	\$73.25	\$2,500.00	\$32,912.57
Casa Berardi Mine	Hecla Québec Inc.	CDC	1098090	-	20240509	55.86	20020911	\$73.25	\$2,500.00	\$0.00
Casa Berardi Mine	Hecla Québec Inc.	CDC	1098091	-	20240509	55.86	20020911	\$73.25	\$2,500.00	\$0.00
Casa Berardi Mine	Hecla Québec Inc.	CDC	1098092	-	20240509	55.86	20020911	\$73.25	\$2,500.00	\$0.00
Casa	Hecla Québec Inc.	CDC	1098093	-	20240509	55.86	20020911	\$73.25	\$2,500.00	\$0.00

5-A  
5-A

Berardi Mine										
Casa Berardi Mine	Hecla Québec Inc.	CDC	1098094	-	20240509	55.86	20020911	\$73.25	\$2,500.00	\$4,610.36
Casa Berardi Mine	Hecla Québec Inc.	CDC	1098095	-	20240509	55.86	20020911	\$73.25	\$2,500.00	\$32,415.08
Casa Berardi Mine	Hecla Québec Inc.	CDC	1098109	-	20240509	42.75	20020911	\$73.25	\$2,500.00	\$336,334.84
Casa Berardi Mine	Hecla Québec Inc.	CDC	1098110	-	20240509	40.23	20020911	\$73.25	\$2,500.00	\$91,214.22
Casa Berardi Mine	Hecla Québec Inc.	CDC	1098111	-	20240509	40.48	20020911	\$73.25	\$2,500.00	\$131,809.79
Casa Berardi Mine	Hecla Québec Inc.	CDC	1098112	-	20240509	40.74	20020911	\$73.25	\$2,500.00	\$1,273,375.74
Casa Berardi Mine	Hecla Québec Inc.	CDC	1098113	-	20240509	42.26	20020911	\$73.25	\$2,500.00	\$403,750.23
Casa Berardi Mine	Hecla Québec Inc.	CDC	1098114	-	20240509	43.76	20020911	\$73.25	\$2,500.00	\$0.00
Casa Berardi Mine	Hecla Québec Inc.	CDC	1098115	-	20240509	51.18	20020911	\$73.25	\$2,500.00	\$444,595.04
Casa Berardi Mine	Hecla Québec Inc.	CDC	1098124	-	20240509	29.58	20020911	\$73.25	\$2,500.00	\$622,121.12
Casa Berardi Mine	Hecla Québec Inc.	CDC	1098125	-	20240509	4.98	20020911	\$37.50	\$1,000.00	\$0.00
Casa	Hecla Québec Inc.	CDC	1098126	-	20240509	20.03	20020911	\$37.50	\$1,000.00	\$5,055.24

6-A  
6-A

Berardi Mine										
Casa Berardi Mine	Hecla Québec Inc.	CDC	1098127	-	20240509	16.16	20020911	\$37.50	\$1,000.00	\$801.54
Casa Berardi Mine	Hecla Québec Inc.	CDC	1098128	-	20240509	13.40	20020911	\$37.50	\$1,000.00	\$200,575.71
Casa Berardi Mine	Hecla Québec Inc.	CDC	1098129	-	20240509	12.86	20020911	\$37.50	\$1,000.00	\$99,315.13
Casa Berardi Mine	Hecla Québec Inc.	CDC	1098130	-	20240509	12.32	20020911	\$37.50	\$1,000.00	\$18,436.02
Casa Berardi Mine	Hecla Québec Inc.	CDC	1098131	-	20240509	0.16	20020911	\$37.50	\$1,000.00	\$0.00
Casa Berardi Mine	Hecla Québec Inc.	CDC	1098132	-	20240509	9.35	20020911	\$37.50	\$1,000.00	\$13,818.50
Casa Berardi Mine	Hecla Québec Inc.	CDC	1098133	-	20240509	5.78	20020911	\$37.50	\$1,000.00	\$57,451.47
Casa Berardi Mine	Hecla Québec Inc.	CDC	1098134	-	20240729	2.32	20020911	\$37.50	\$1,000.00	\$0.00
Casa Berardi Mine	Hecla Québec Inc.	CDC	1098135	-	20240509	11.42	20020911	\$37.50	\$1,000.00	\$59,185.51
Casa Berardi Mine	Hecla Québec Inc.	CDC	1098136	-	20240729	14.22	20020911	\$37.50	\$1,000.00	\$369,866.50
Casa Berardi Mine	Hecla Québec Inc.	CDC	1098141	-	20240509	6.06	20020911	\$37.50	\$1,000.00	\$0.00
Casa	Hecla Québec Inc.	CDC	1098142	-	20240509	48.61	20020911	\$73.25	\$2,500.00	\$6,782.24

7-A  
7-A

Berardi Mine										
Casa Berardi Mine	Hecla Québec Inc.	CDC	1098149	-	20240509	55.82	20020911	\$73.25	\$2,500.00	\$0.00
Casa Berardi Mine	Hecla Québec Inc.	CDC	2639908	-	20250308	55.81	20220309	\$73.25	\$1,200.00	\$0.00
Casa Berardi Mine	Hecla Québec Inc.	CDC	2639909	-	20250308	55.81	20220309	\$73.25	\$1,200.00	\$0.00
Casa Berardi Regional	Hecla Québec Inc.	CDC	2639910	-	20250308	55.81	20220309	\$73.25	\$1,200.00	\$0.00
Casa Berardi Regional	Hecla Québec Inc.	CDC	2639911	-	20250308	55.82	20220309	\$73.25	\$1,200.00	\$0.00
Casa Berardi Regional	Hecla Québec Inc.	CDC	2639912	-	20250308	55.82	20220309	\$73.25	\$1,200.00	\$0.00
Casa Berardi Regional	Hecla Québec Inc.	CDC	2639913	-	20250308	55.82	20220309	\$73.25	\$1,200.00	\$0.00
Casa Berardi Regional	Hecla Québec Inc.	CDC	2639914	-	20250308	55.82	20220309	\$73.25	\$1,200.00	\$0.00
Casa Berardi Regional	Hecla Québec Inc.	CDC	2639915	-	20250308	55.82	20220309	\$73.25	\$1,200.00	\$0.00
Casa Berardi Regional	Hecla Québec Inc.	CDC	2639916	-	20250308	55.82	20220309	\$73.25	\$1,200.00	\$0.00

8-A  
8-A

Casa Berardi Regional	Hecla Québec Inc.	CDC	2639917	-	20250308	55.82	20220309	\$73.25	\$1,200.00	\$0.00
Casa Berardi Regional	Hecla Québec Inc.	CDC	2639918	-	20250308	55.82	20220309	\$73.25	\$1,200.00	\$0.00
Casa Berardi Regional	Hecla Québec Inc.	BM (Mining Lease)	768	-	20240428	397.09	19880429	\$22,304.47	\$0.00	\$0.00
Casa Berardi Regional	Hecla Québec Inc.	BM (Mining Lease)	833	-	20241217	84.35	19951218	\$4,533.81	\$0.00	\$0.00
Casa Berardi Regional	Hecla Québec Inc.	CDC	1097832	-	20240509	55.89	20020911	\$73.25	\$2,500.00	\$10,929.20
Casa Berardi Regional	Hecla Québec Inc.	CDC	1097833	-	20240509	55.90	20020911	\$73.25	\$2,500.00	\$10,390.16
Casa Berardi Regional	Hecla Québec Inc.	CDC	1097834	-	20240509	55.90	20020911	\$73.25	\$2,500.00	\$7,215.16
Casa Berardi Regional	Hecla Québec Inc.	CDC	1097835	-	20240509	55.90	20020911	\$73.25	\$2,500.00	\$7,215.16
Casa Berardi Regional	Hecla Québec Inc.	CDC	1097836	-	20240509	55.90	20020911	\$73.25	\$2,500.00	\$11,021.09
Casa Berardi Regional	Hecla Québec Inc.	CDC	1097837	-	20240509	55.90	20020911	\$73.25	\$2,500.00	\$9,215.16

9-A  
9-A

Casa Berardi Regional	Hecla Québec Inc.	CDC	1097840	-	20240509	55.89	20020911	\$73.25	\$2,500.00	\$10,020.35
Casa Berardi Regional	Hecla Québec Inc.	CDC	1097841	-	20240509	55.89	20020911	\$73.25	\$2,500.00	\$8,709.20
Casa Berardi Regional	Hecla Québec Inc.	CDC	1097842	-	20240509	55.89	20020911	\$73.25	\$2,500.00	\$8,784.20
Casa Berardi Regional	Hecla Québec Inc.	CDC	1097843	-	20240509	55.89	20020911	\$73.25	\$2,500.00	\$7,209.20
Casa Berardi Regional	Hecla Québec Inc.	CDC	1097844	-	20240509	55.89	20020911	\$73.25	\$2,500.00	\$9,709.20
Casa Berardi Regional	Hecla Québec Inc.	CDC	1097845	-	20240509	55.89	20020911	\$73.25	\$2,500.00	\$10,157.33
Casa Berardi Regional	Hecla Québec Inc.	CDC	1097846	-	20240509	55.89	20020911	\$73.25	\$2,500.00	\$9,634.38
Casa Berardi Regional	Hecla Québec Inc.	CDC	1097847	-	20240509	55.89	20020911	\$73.25	\$2,500.00	\$5,307.12
Casa Berardi Regional	Hecla Québec Inc.	CDC	1097848	-	20240509	55.89	20020911	\$73.25	\$2,500.00	\$9,209.20
Casa Berardi Regional	Hecla Québec Inc.	CDC	1097849	-	20240509	55.89	20020911	\$73.25	\$2,500.00	\$9,209.20

10-A  
10-A

Casa Berardi Regional	Hecla Québec Inc.	CDC	1097851	-	20240509	55.88	20020911	\$73.25	\$2,500.00	\$10,503.23
Casa Berardi Regional	Hecla Québec Inc.	CDC	1097852	-	20240509	55.88	20020911	\$73.25	\$2,500.00	\$9,203.23
Casa Berardi Regional	Hecla Québec Inc.	CDC	1097853	-	20240509	55.88	20020911	\$73.25	\$2,500.00	\$11,703.23
Casa Berardi Regional	Hecla Québec Inc.	CDC	1097854	-	20240509	55.88	20020911	\$73.25	\$2,500.00	\$11,703.23
Casa Berardi Regional	Hecla Québec Inc.	CDC	1097855	-	20240509	55.88	20020911	\$73.25	\$2,500.00	\$9,203.23
Casa Berardi Regional	Hecla Québec Inc.	CDC	1097856	-	20240509	55.88	20020911	\$73.25	\$2,500.00	\$7,300.55
Casa Berardi Regional	Hecla Québec Inc.	CDC	1097857	-	20240509	55.88	20020911	\$73.25	\$2,500.00	\$9,203.23
Casa Berardi Regional	Hecla Québec Inc.	CDC	1097858	-	20240509	55.88	20020911	\$73.25	\$2,500.00	\$9,260.18
Casa Berardi Regional	Hecla Québec Inc.	CDC	1097859	-	20240509	55.88	20020911	\$73.25	\$2,500.00	\$11,703.23
Casa Berardi Regional	Hecla Québec Inc.	CDC	1097860	-	20240509	55.88	20020911	\$73.25	\$2,500.00	\$11,703.23

11-A  
11-A

Casa Berardi Regional	Hecla Québec Inc.	CDC	1097861	-	20240509	55.88	20020911	\$73.25	\$2,500.00	\$11,703.23
Casa Berardi Regional	Hecla Québec Inc.	CDC	1097862	-	20240509	55.88	20020911	\$73.25	\$2,500.00	\$11,703.23
Casa Berardi Regional	Hecla Québec Inc.	CDC	1097863	-	20240509	55.88	20020911	\$73.25	\$2,500.00	\$43,631.60
Casa Berardi Regional	Hecla Québec Inc.	CDC	1097864	-	20240509	55.88	20020911	\$73.25	\$2,500.00	\$22,578.52
Casa Berardi Regional	Hecla Québec Inc.	CDC	1097865	-	20240509	55.88	20020911	\$73.25	\$2,500.00	\$60,153.79
Casa Berardi Regional	Hecla Québec Inc.	CDC	1097866	-	20240509	55.88	20020911	\$73.25	\$2,500.00	\$5,703.23
Casa Berardi Regional	Hecla Québec Inc.	CDC	1097867	-	20240509	55.87	20020911	\$73.25	\$2,500.00	\$10,497.27
Casa Berardi Regional	Hecla Québec Inc.	CDC	1097868	-	20240509	55.87	20020911	\$73.25	\$2,500.00	\$11,697.27
Casa Berardi Regional	Hecla Québec Inc.	CDC	1097869	-	20240509	55.87	20020911	\$73.25	\$2,500.00	\$11,697.27
Casa Berardi Regional	Hecla Québec Inc.	CDC	1097870	-	20240509	55.87	20020911	\$73.25	\$2,500.00	\$11,697.27

12-A  
12-A

Casa Berardi Regional	Hecla Québec Inc.	CDC	1097871	-	20240509	55.87	20020911	\$73.25	\$2,500.00	\$11,697.27
Casa Berardi Regional	Hecla Québec Inc.	CDC	1097872	-	20240509	55.87	20020911	\$73.25	\$2,500.00	\$11,697.27
Casa Berardi Regional	Hecla Québec Inc.	CDC	1097873	-	20240509	55.87	20020911	\$73.25	\$2,500.00	\$11,697.27
Casa Berardi Regional	Hecla Québec Inc.	CDC	1097874	-	20240509	55.87	20020911	\$73.25	\$2,500.00	\$11,697.27
Casa Berardi Regional	Hecla Québec Inc.	CDC	1097875	-	20240509	55.87	20020911	\$73.25	\$2,500.00	\$11,697.27
Casa Berardi Regional	Hecla Québec Inc.	CDC	1097876	-	20240509	55.87	20020911	\$73.25	\$2,500.00	\$0.00
Casa Berardi Regional	Hecla Québec Inc.	CDC	1097877	-	20240509	55.87	20020911	\$73.25	\$2,500.00	\$11,697.27
Casa Berardi Regional	Hecla Québec Inc.	CDC	1097878	-	20240509	55.87	20020911	\$73.25	\$2,500.00	\$74,111.83
Casa Berardi Regional	Hecla Québec Inc.	CDC	1097879	-	20240509	55.87	20020911	\$73.25	\$2,500.00	\$11,697.27
Casa Berardi Regional	Hecla Québec Inc.	CDC	1097880	-	20240509	55.86	20020911	\$73.25	\$2,500.00	\$11,691.31

13-A  
13-A

Casa Berardi Regional	Hecla Québec Inc.	CDC	1097881	-	20240509	55.86	20020911	\$73.25	\$2,500.00	\$11,691.31
Casa Berardi Regional	Hecla Québec Inc.	CDC	1097882	-	20240509	55.86	20020911	\$73.25	\$2,500.00	\$11,691.31
Casa Berardi Regional	Hecla Québec Inc.	CDC	1097883	-	20240509	55.86	20020911	\$73.25	\$2,500.00	\$11,691.31
Casa Berardi Regional	Hecla Québec Inc.	CDC	1097884	-	20240509	55.86	20020911	\$73.25	\$2,500.00	\$11,691.31
Casa Berardi Regional	Hecla Québec Inc.	CDC	1097885	-	20240509	55.86	20020911	\$73.25	\$2,500.00	\$44,427.36
Casa Berardi Regional	Hecla Québec Inc.	CDC	1097886	-	20240509	55.86	20020911	\$73.25	\$2,500.00	\$10,491.31
Casa Berardi Regional	Hecla Québec Inc.	CDC	1097895	-	20240509	55.85	20020911	\$73.25	\$2,500.00	\$9,285.34
Casa Berardi Regional	Hecla Québec Inc.	CDC	1097896	-	20240509	55.85	20020911	\$73.25	\$2,500.00	\$128,248.74
Casa Berardi Regional	Hecla Québec Inc.	CDC	1097897	-	20240509	55.85	20020911	\$73.25	\$2,500.00	\$609,898.82
Casa Berardi Regional	Hecla Québec Inc.	CDC	1097898	-	20240509	55.85	20020911	\$73.25	\$2,500.00	\$788,714.03

14-A  
14-A

Casa Berardi Regional	Hecla Québec Inc.	CDC	1097899	-	20240509	55.85	20020911	\$73.25	\$2,500.00	\$1,165,342.42
Casa Berardi Regional	Hecla Québec Inc.	CDC	1097900	-	20240509	55.85	20020911	\$73.25	\$2,500.00	\$1,529,499.74
Casa Berardi Regional	Hecla Québec Inc.	CDC	1097907	-	20240509	55.85	20020911	\$73.25	\$2,500.00	\$11,685.34
Casa Berardi Regional	Hecla Québec Inc.	CDC	1097908	-	20240509	55.85	20020911	\$73.25	\$2,500.00	\$11,685.34
Casa Berardi Regional	Hecla Québec Inc.	CDC	1097909	-	20240509	55.86	20020911	\$73.25	\$2,500.00	\$11,691.31
Casa Berardi Regional	Hecla Québec Inc.	CDC	1097910	-	20240509	55.86	20020911	\$73.25	\$2,500.00	\$16,853.31
Casa Berardi Regional	Hecla Québec Inc.	CDC	1097911	-	20240509	55.86	20020911	\$73.25	\$2,500.00	\$28,943.31
Casa Berardi Regional	Hecla Québec Inc.	CDC	1097912	-	20240509	55.86	20020911	\$73.25	\$2,500.00	\$32,009.31
Casa Berardi Regional	Hecla Québec Inc.	CDC	1097913	-	20240509	55.86	20020911	\$73.25	\$2,500.00	\$34,961.31
Casa Berardi Regional	Hecla Québec Inc.	CDC	1097914	-	20240509	55.86	20020911	\$73.25	\$2,500.00	\$25,094.31

15-A  
15-A

Casa Berardi Regional	Hecla Québec Inc.	CDC	1097915	-	20240509	55.86	20020911	\$73.25	\$2,500.00	\$27,248.31
Casa Berardi Regional	Hecla Québec Inc.	CDC	1097916	-	20240509	55.86	20020911	\$73.25	\$2,500.00	\$24,815.31
Casa Berardi Regional	Hecla Québec Inc.	CDC	1097917	-	20240509	55.86	20020911	\$73.25	\$2,500.00	\$20,138.31
Casa Berardi Regional	Hecla Québec Inc.	CDC	1097918	-	20240509	55.86	20020911	\$73.25	\$2,500.00	\$27,615.31
Casa Berardi Regional	Hecla Québec Inc.	CDC	1097919	-	20240509	55.86	20020911	\$73.25	\$2,500.00	\$28,240.31
Casa Berardi Regional	Hecla Québec Inc.	CDC	1097920	-	20240509	55.86	20020911	\$73.25	\$2,500.00	\$29,716.31
Casa Berardi Regional	Hecla Québec Inc.	CDC	1097921	-	20240509	55.86	20020911	\$73.25	\$2,500.00	\$33,625.31
Casa Berardi Regional	Hecla Québec Inc.	CDC	1097922	-	20240509	55.86	20020911	\$73.25	\$2,500.00	\$32,801.31
Casa Berardi Regional	Hecla Québec Inc.	CDC	1097925	-	20240509	55.84	20020911	\$73.25	\$2,500.00	\$11,679.37
Casa Berardi Regional	Hecla Québec Inc.	CDC	1097926	-	20240509	55.84	20020911	\$73.25	\$2,500.00	\$44,660.16

16-A  
16-A

Casa Berardi Regional	Hecla Québec Inc.	CDC	1097927	-	20240509	55.84	20020911	\$73.25	\$2,500.00	\$26,075.23
Casa Berardi Regional	Hecla Québec Inc.	CDC	1097928	-	20240509	55.84	20020911	\$73.25	\$2,500.00	\$62,140.41
Casa Berardi Regional	Hecla Québec Inc.	CDC	1097929	-	20240509	55.84	20020911	\$73.25	\$2,500.00	\$68,281.47
Casa Berardi Regional	Hecla Québec Inc.	CDC	1097933	-	20240509	55.85	20020911	\$73.25	\$2,500.00	\$14,185.34
Casa Berardi Regional	Hecla Québec Inc.	CDC	1097934	-	20240509	55.85	20020911	\$73.25	\$2,500.00	\$11,685.34
Casa Berardi Regional	Hecla Québec Inc.	CDC	1097935	-	20240509	55.85	20020911	\$73.25	\$2,500.00	\$11,685.34
Casa Berardi Regional	Hecla Québec Inc.	CDC	1097936	-	20240509	55.85	20020911	\$73.25	\$2,500.00	\$25,685.34
Casa Berardi Regional	Hecla Québec Inc.	CDC	1097937	-	20240509	55.85	20020911	\$73.25	\$2,500.00	\$25,512.34
Casa Berardi Regional	Hecla Québec Inc.	CDC	1097938	-	20240509	55.85	20020911	\$73.25	\$2,500.00	\$24,561.34
Casa Berardi Regional	Hecla Québec Inc.	CDC	1097939	-	20240509	55.85	20020911	\$73.25	\$2,500.00	\$16,687.34

17-A  
17-A

Casa Berardi Regional	Hecla Québec Inc.	CDC	1097940	-	20240509	55.85	20020911	\$73.25	\$2,500.00	\$11,685.34
Casa Berardi Regional	Hecla Québec Inc.	CDC	1097941	-	20240509	55.85	20020911	\$73.25	\$2,500.00	\$11,685.34
Casa Berardi Regional	Hecla Québec Inc.	CDC	1097942	-	20240509	55.85	20020911	\$73.25	\$2,500.00	\$11,685.34
Casa Berardi Regional	Hecla Québec Inc.	CDC	1097943	-	20240509	55.85	20020911	\$73.25	\$2,500.00	\$11,685.34
Casa Berardi Regional	Hecla Québec Inc.	CDC	1097944	-	20240509	55.85	20020911	\$73.25	\$2,500.00	\$11,685.34
Casa Berardi Regional	Hecla Québec Inc.	CDC	1097945	-	20240509	55.85	20020911	\$73.25	\$2,500.00	\$11,685.34
Casa Berardi Regional	Hecla Québec Inc.	CDC	1097946	-	20240509	55.85	20020911	\$73.25	\$2,500.00	\$11,685.34
Casa Berardi Regional	Hecla Québec Inc.	CDC	1097947	-	20240509	55.85	20020911	\$73.25	\$2,500.00	\$22,986.34
Casa Berardi Regional	Hecla Québec Inc.	CDC	1097948	-	20240509	55.85	20020911	\$73.25	\$2,500.00	\$24,077.34
Casa Berardi Regional	Hecla Québec Inc.	CDC	1097949	-	20240509	55.85	20020911	\$73.25	\$2,500.00	\$21,582.34

18-A  
18-A

Casa Berardi Regional	Hecla Québec Inc.	CDC	1097950	-	20240509	55.85	20020911	\$73.25	\$2,500.00	\$14,836.34
Casa Berardi Regional	Hecla Québec Inc.	CDC	1097951	-	20240509	55.85	20020911	\$73.25	\$2,500.00	\$16,105.34
Casa Berardi Regional	Hecla Québec Inc.	CDC	1097952	-	20240509	55.83	20020911	\$73.25	\$2,500.00	\$11,673.41
Casa Berardi Regional	Hecla Québec Inc.	CDC	1097953	-	20240509	55.83	20020911	\$73.25	\$2,500.00	\$11,673.41
Casa Berardi Regional	Hecla Québec Inc.	CDC	1097954	-	20240509	55.83	20020911	\$73.25	\$2,500.00	\$11,673.41
Casa Berardi Regional	Hecla Québec Inc.	CDC	1097955	-	20240509	55.83	20020911	\$73.25	\$2,500.00	\$11,673.41
Casa Berardi Regional	Hecla Québec Inc.	CDC	1097956	-	20240509	55.83	20020911	\$73.25	\$2,500.00	\$11,673.41
Casa Berardi Regional	Hecla Québec Inc.	CDC	1097969	-	20240509	55.84	20020911	\$73.25	\$2,500.00	\$123,152.89
Casa Berardi Regional	Hecla Québec Inc.	CDC	1097970	-	20240509	55.84	20020911	\$73.25	\$2,500.00	\$117,817.37
Casa Berardi Regional	Hecla Québec Inc.	CDC	1097971	-	20240509	55.84	20020911	\$73.25	\$2,500.00	\$11,679.37

19-A  
19-A

Casa Berardi Regional	Hecla Québec Inc.	CDC	1097972	-	20240509	55.84	20020911	\$73.25	\$2,500.00	\$11,679.37
Casa Berardi Regional	Hecla Québec Inc.	CDC	1097973	-	20240509	55.84	20020911	\$73.25	\$2,500.00	\$27,642.37
Casa Berardi Regional	Hecla Québec Inc.	CDC	1097974	-	20240509	55.84	20020911	\$73.25	\$2,500.00	\$81,151.37
Casa Berardi Regional	Hecla Québec Inc.	CDC	1097975	-	20240509	55.84	20020911	\$73.25	\$2,500.00	\$27,430.37
Casa Berardi Regional	Hecla Québec Inc.	CDC	1097976	-	20240509	55.84	20020911	\$73.25	\$2,500.00	\$24,065.37
Casa Berardi Regional	Hecla Québec Inc.	CDC	1097977	-	20240509	55.84	20020911	\$73.25	\$2,500.00	\$11,679.37
Casa Berardi Regional	Hecla Québec Inc.	CDC	1097978	-	20240509	55.84	20020911	\$73.25	\$2,500.00	\$11,679.37
Casa Berardi Regional	Hecla Québec Inc.	CDC	1097979	-	20240509	55.84	20020911	\$73.25	\$2,500.00	\$11,679.37
Casa Berardi Regional	Hecla Québec Inc.	CDC	1097980	-	20240509	55.84	20020911	\$73.25	\$2,500.00	\$11,679.37
Casa Berardi Regional	Hecla Québec Inc.	CDC	1097981	-	20240509	55.84	20020911	\$73.25	\$2,500.00	\$11,679.37

20-A  
20-A

Casa Berardi Regional	Hecla Québec Inc.	CDC	1097982	-	20240509	55.84	20020911	\$73.25	\$2,500.00	\$11,679.37
Casa Berardi Regional	Hecla Québec Inc.	CDC	1097983	-	20240509	55.84	20020911	\$73.25	\$2,500.00	\$11,679.37
Casa Berardi Regional	Hecla Québec Inc.	CDC	1097984	-	20240509	55.84	20020911	\$73.25	\$2,500.00	\$11,679.37
Casa Berardi Regional	Hecla Québec Inc.	CDC	1097985	-	20240509	55.84	20020911	\$73.25	\$2,500.00	\$11,679.37
Casa Berardi Regional	Hecla Québec Inc.	CDC	1097986	-	20240509	55.84	20020911	\$73.25	\$2,500.00	\$11,679.37
Casa Berardi Regional	Hecla Québec Inc.	CDC	1097987	-	20240509	55.84	20020911	\$73.25	\$2,500.00	\$11,679.37
Casa Berardi Regional	Hecla Québec Inc.	CDC	1097988	-	20240509	55.84	20020911	\$73.25	\$2,500.00	\$11,679.37
Casa Berardi Regional	Hecla Québec Inc.	CDC	1097989	-	20240509	55.84	20020911	\$73.25	\$2,500.00	\$11,679.37
Casa Berardi Regional	Hecla Québec Inc.	CDC	1098003	-	20240509	55.83	20020911	\$73.25	\$2,500.00	\$11,673.41
Casa Berardi Regional	Hecla Québec Inc.	CDC	1098004	-	20240509	55.83	20020911	\$73.25	\$2,500.00	\$11,673.41

21-A  
21-A

Casa Berardi Regional	Hecla Québec Inc.	CDC	1098005	-	20240509	55.83	20020911	\$73.25	\$2,500.00	\$11,673.41
Casa Berardi Regional	Hecla Québec Inc.	CDC	1098006	-	20240509	55.83	20020911	\$73.25	\$2,500.00	\$11,673.41
Casa Berardi Regional	Hecla Québec Inc.	CDC	1098007	-	20240509	55.83	20020911	\$73.25	\$2,500.00	\$11,673.41
Casa Berardi Regional	Hecla Québec Inc.	CDC	1098008	-	20240509	55.83	20020911	\$73.25	\$2,500.00	\$148,405.34
Casa Berardi Regional	Hecla Québec Inc.	CDC	1098009	-	20240509	55.83	20020911	\$73.25	\$2,500.00	\$11,673.41
Casa Berardi Regional	Hecla Québec Inc.	CDC	1098010	-	20240509	55.83	20020911	\$73.25	\$2,500.00	\$11,673.41
Casa Berardi Regional	Hecla Québec Inc.	CDC	1098011	-	20240509	55.83	20020911	\$73.25	\$2,500.00	\$1,180,088.20
Casa Berardi Regional	Hecla Québec Inc.	CDC	1098012	-	20240509	55.83	20020911	\$73.25	\$2,500.00	\$2,213,769.20
Casa Berardi Regional	Hecla Québec Inc.	CDC	1098013	-	20240509	55.83	20020911	\$73.25	\$2,500.00	\$11,673.41
Casa Berardi Regional	Hecla Québec Inc.	CDC	1098014	-	20240509	55.83	20020911	\$73.25	\$2,500.00	\$11,673.41

22-A  
22-A

Casa Berardi Regional	Hecla Québec Inc.	CDC	1098015	-	20240509	55.83	20020911	\$73.25	\$2,500.00	\$11,673.41
Casa Berardi Regional	Hecla Québec Inc.	CDC	1098016	-	20240509	55.83	20020911	\$73.25	\$2,500.00	\$11,673.41
Casa Berardi Regional	Hecla Québec Inc.	CDC	1098017	-	20240509	55.83	20020911	\$73.25	\$2,500.00	\$131,221.23
Casa Berardi Regional	Hecla Québec Inc.	CDC	1098018	-	20240509	55.83	20020911	\$73.25	\$2,500.00	\$11,673.41
Casa Berardi Regional	Hecla Québec Inc.	CDC	1098019	-	20240509	55.83	20020911	\$73.25	\$2,500.00	\$11,673.41
Casa Berardi Regional	Hecla Québec Inc.	CDC	1098020	-	20240509	55.83	20020911	\$73.25	\$2,500.00	\$19,636.06
Casa Berardi Regional	Hecla Québec Inc.	CDC	1098021	-	20240509	55.83	20020911	\$73.25	\$2,500.00	\$19,688.79
Casa Berardi Regional	Hecla Québec Inc.	CDC	1098022	-	20240509	55.83	20020911	\$73.25	\$2,500.00	\$20,879.41
Casa Berardi Regional	Hecla Québec Inc.	CDC	1098023	-	20240509	55.83	20020911	\$73.25	\$2,500.00	\$11,673.41
Casa Berardi Regional	Hecla Québec Inc.	CDC	1098024	-	20240509	55.83	20020911	\$73.25	\$2,500.00	\$11,673.41

23-A  
23-A

Casa Berardi Regional	Hecla Québec Inc.	CDC	1098025	-	20240509	55.83	20020911	\$73.25	\$2,500.00	\$11,673.41
Casa Berardi Regional	Hecla Québec Inc.	CDC	1098026	-	20240509	55.83	20020911	\$73.25	\$2,500.00	\$11,673.41
Casa Berardi Regional	Hecla Québec Inc.	CDC	1098027	-	20240509	55.82	20020911	\$73.25	\$2,500.00	\$11,667.46
Casa Berardi Regional	Hecla Québec Inc.	CDC	1098028	-	20240509	55.82	20020911	\$73.25	\$2,500.00	\$11,667.46
Casa Berardi Regional	Hecla Québec Inc.	CDC	1098029	-	20240509	55.82	20020911	\$73.25	\$2,500.00	\$11,667.46
Casa Berardi Regional	Hecla Québec Inc.	CDC	1098030	-	20240509	55.82	20020911	\$73.25	\$2,500.00	\$11,667.46
Casa Berardi Regional	Hecla Québec Inc.	CDC	1098031	-	20240509	55.82	20020911	\$73.25	\$2,500.00	\$11,667.46
Casa Berardi Regional	Hecla Québec Inc.	CDC	1098032	-	20240509	55.82	20020911	\$73.25	\$2,500.00	\$11,667.46
Casa Berardi Regional	Hecla Québec Inc.	CDC	1098033	-	20240509	55.82	20020911	\$73.25	\$2,500.00	\$11,667.46
Casa Berardi Regional	Hecla Québec Inc.	CDC	1098034	-	20240509	55.82	20020911	\$73.25	\$2,500.00	\$11,667.46

24-A  
24-A

Casa Berardi Regional	Hecla Québec Inc.	CDC	1098035	-	20240509	55.82	20020911	\$73.25	\$2,500.00	\$11,667.46
Casa Berardi Regional	Hecla Québec Inc.	CDC	1098036	-	20240509	55.82	20020911	\$73.25	\$2,500.00	\$11,667.46
Casa Berardi Regional	Hecla Québec Inc.	CDC	1098037	-	20240509	55.82	20020911	\$73.25	\$2,500.00	\$11,667.46
Casa Berardi Regional	Hecla Québec Inc.	CDC	1098038	-	20240509	55.82	20020911	\$73.25	\$2,500.00	\$11,667.46
Casa Berardi Regional	Hecla Québec Inc.	CDC	1098039	-	20240509	55.82	20020911	\$73.25	\$2,500.00	\$11,667.46
Casa Berardi Regional	Hecla Québec Inc.	CDC	1098040	-	20240509	55.82	20020911	\$73.25	\$2,500.00	\$11,667.46
Casa Berardi Regional	Hecla Québec Inc.	CDC	1098042	-	20240509	55.82	20020911	\$73.25	\$2,500.00	\$11,667.46
Casa Berardi Regional	Hecla Québec Inc.	CDC	1098043	-	20240509	55.82	20020911	\$73.25	\$2,500.00	\$11,667.46
Casa Berardi Regional	Hecla Québec Inc.	CDC	1098044	-	20240509	55.82	20020911	\$73.25	\$2,500.00	\$11,667.46
Casa Berardi Regional	Hecla Québec Inc.	CDC	1098045	-	20240509	55.82	20020911	\$73.25	\$2,500.00	\$11,667.46

25-A  
25-A

Casa Berardi Regional	Hecla Québec Inc.	CDC	1098061	-	20240509	29.17	20020911	\$73.25	\$2,500.00	\$0.00
Casa Berardi Regional	Hecla Québec Inc.	CDC	1098062	-	20240509	25.83	20020911	\$73.25	\$2,500.00	\$0.00
Casa Berardi Regional	Hecla Québec Inc.	CDC	1098063	-	20240509	25.11	20020911	\$73.25	\$2,500.00	\$0.00
Casa Berardi Regional	Hecla Québec Inc.	CDC	1098064	-	20240509	25.33	20020911	\$73.25	\$2,500.00	\$0.00
Casa Berardi Regional	Hecla Québec Inc.	CDC	1098065	-	20240509	25.36	20020911	\$73.25	\$2,500.00	\$0.00
Casa Berardi Regional	Hecla Québec Inc.	CDC	1098066	-	20240509	55.77	20020911	\$73.25	\$2,500.00	\$11,637.63
Casa Berardi Regional	Hecla Québec Inc.	CDC	1098067	-	20240509	55.88	20020911	\$73.25	\$2,500.00	\$0.00
Casa Berardi Regional	Hecla Québec Inc.	CDC	1098068	-	20240509	25.81	20020911	\$73.25	\$2,500.00	\$0.00
Casa Berardi Regional	Hecla Québec Inc.	CDC	1098069	-	20240509	27.82	20020911	\$73.25	\$2,500.00	\$0.00
Casa Berardi Regional	Hecla Québec Inc.	CDC	1098070	-	20240509	28.54	20020911	\$73.25	\$2,500.00	\$0.00

26-A  
26-A

Casa Berardi Regional	Hecla Québec Inc.	CDC	1098071	-	20240509	38.86	20020911	\$73.25	\$2,500.00	\$1,552.08
Casa Berardi Regional	Hecla Québec Inc.	CDC	1098072	-	20240509	55.87	20020911	\$73.25	\$2,500.00	\$1,257.90
Casa Berardi Regional	Hecla Québec Inc.	CDC	1098076	-	20240509	4.89	20020911	\$37.50	\$1,000.00	\$0.00
Casa Berardi Regional	Hecla Québec Inc.	CDC	1098077	-	20240509	14.30	20020911	\$37.50	\$1,000.00	\$0.00
Casa Berardi Regional	Hecla Québec Inc.	CDC	1098078	-	20240509	16.88	20020911	\$37.50	\$1,000.00	\$1,417.65
Casa Berardi Regional	Hecla Québec Inc.	CDC	1098079	-	20240509	36.16	20020911	\$73.25	\$2,500.00	\$0.00
Casa Berardi Regional	Hecla Québec Inc.	CDC	1098080	-	20240509	38.65	20020911	\$73.25	\$2,500.00	\$1,426.83
Casa Berardi Regional	Hecla Québec Inc.	CDC	1098081	-	20240509	36.52	20020911	\$73.25	\$2,500.00	\$156.44
Casa Berardi Regional	Hecla Québec Inc.	CDC	1098082	-	20240509	36.82	20020911	\$73.25	\$2,500.00	\$335.37
Casa Berardi Regional	Hecla Québec Inc.	CDC	1098083	-	20240509	50.28	20020911	\$73.25	\$2,500.00	\$8,363.25

27-A  
27-A

Casa Berardi Regional	Hecla Québec Inc.	CDC	1098084	-	20240509	55.86	20020911	\$73.25	\$2,500.00	\$4,419.99
Casa Berardi Regional	Hecla Québec Inc.	CDC	1098096	-	20240509	55.86	20020911	\$73.25	\$2,500.00	\$0.00
Casa Berardi Regional	Hecla Québec Inc.	CDC	1098104	-	20240509	25.51	20020911	\$73.25	\$2,500.00	\$0.00
Casa Berardi Regional	Hecla Québec Inc.	CDC	1098105	-	20240509	13.04	20020911	\$37.50	\$1,000.00	\$69,240.52
Casa Berardi Regional	Hecla Québec Inc.	CDC	1098106	-	20240509	5.21	20020911	\$37.50	\$1,000.00	\$0.00
Casa Berardi Regional	Hecla Québec Inc.	CDC	1098107	-	20240509	6.93	20020911	\$37.50	\$1,000.00	\$0.00
Casa Berardi Regional	Hecla Québec Inc.	CDC	1098108	-	20240509	40.38	20020911	\$73.25	\$2,500.00	\$2,458.64
Casa Berardi Regional	Hecla Québec Inc.	CDC	1098118	-	20240509	55.84	20020911	\$73.25	\$2,500.00	\$0.00
Casa Berardi Regional	Hecla Québec Inc.	CDC	1098119	-	20240509	55.84	20020911	\$73.25	\$2,500.00	\$388.96
Casa Berardi Regional	Hecla Québec Inc.	CDC	1098120	-	20240509	55.84	20020911	\$73.25	\$2,500.00	\$2,718.82

28-A  
28-A

Casa Berardi Regional	Hecla Québec Inc.	CDC	1098121	-	20240509	55.84	20020911	\$73.25	\$2,500.00	\$3,092.91
Casa Berardi Regional	Hecla Québec Inc.	CDC	1098122	-	20240509	55.84	20020911	\$73.25	\$2,500.00	\$9,534.22
Casa Berardi Regional	Hecla Québec Inc.	CDC	1098123	-	20240509	55.84	20020911	\$73.25	\$2,500.00	\$10,650.64
Casa Berardi Regional	Hecla Québec Inc.	CDC	1098137	-	20240509	34.60	20020911	\$73.25	\$2,500.00	\$0.00
Casa Berardi Regional	Hecla Québec Inc.	CDC	1098138	-	20240509	9.95	20020911	\$37.50	\$1,000.00	\$0.00
Casa Berardi Regional	Hecla Québec Inc.	CDC	1098143	-	20240509	52.13	20020911	\$73.25	\$2,500.00	\$8,166.63
Casa Berardi Regional	Hecla Québec Inc.	CDC	1098144	-	20240509	43.22	20020911	\$73.25	\$2,500.00	\$4,152.49
Casa Berardi Regional	Hecla Québec Inc.	CDC	1098145	-	20240509	36.24	20020911	\$73.25	\$2,500.00	\$0.00
Casa Berardi Regional	Hecla Québec Inc.	CDC	1098146	-	20240509	7.95	20020911	\$37.50	\$1,000.00	\$0.00
Casa Berardi Regional	Hecla Québec Inc.	CDC	1098147	-	20240509	9.91	20020911	\$37.50	\$1,000.00	\$0.00

29-A  
29-A

Casa Berardi Regional	Hecla Québec Inc.	CDC	1098150	-	20240509	55.82	20020911	\$73.25	\$2,500.00	\$0.00
Casa Berardi Regional	Hecla Québec Inc.	CDC	1098151	-	20240509	55.82	20020911	\$73.25	\$2,500.00	\$0.00
Casa Berardi Regional	Hecla Québec Inc.	CDC	1098152	-	20240509	55.82	20020911	\$73.25	\$2,500.00	\$0.00
Casa Berardi Regional	Hecla Québec Inc.	CDC	1098153	-	20240509	55.82	20020911	\$73.25	\$2,500.00	\$0.00
Casa Berardi Regional	Hecla Québec Inc.	CDC	1098157	-	20240509	55.89	20020911	\$73.25	\$2,500.00	\$0.00
Casa Berardi Regional	Hecla Québec Inc.	CDC	1098158	-	20240509	55.89	20020911	\$73.25	\$2,500.00	\$0.00
Casa Berardi Regional	Hecla Québec Inc.	CDC	1098159	-	20240509	55.89	20020911	\$73.25	\$2,500.00	\$0.00
Casa Berardi Regional	Hecla Québec Inc.	CDC	1098160	-	20240509	36.25	20020911	\$73.25	\$2,500.00	\$3,327.12
Casa Berardi Regional	Hecla Québec Inc.	CDC	1098161	-	20240509	30.31	20020911	\$73.25	\$2,500.00	\$0.00
Casa Berardi Regional	Hecla Québec Inc.	CDC	1133304	-	20260111	26.71	20050902	\$73.25	\$2,500.00	\$0.00

30-A  
30-A

Casa Berardi Regional	Hecla Québec Inc.	CDC	1133305	-	20260111	30.05	20050902	\$73.25	\$2,500.00	\$1,367.50
Casa Berardi Regional	Hecla Québec Inc.	CDC	1133306	-	20260111	30.76	20050902	\$73.25	\$2,500.00	\$1,831.01
Casa Berardi Regional	Hecla Québec Inc.	CDC	1133307	-	20260111	30.55	20050902	\$73.25	\$2,500.00	\$1,693.91
Casa Berardi Regional	Hecla Québec Inc.	CDC	1133308	-	20260111	30.52	20050902	\$73.25	\$2,500.00	\$739.61
Casa Berardi Regional	Hecla Québec Inc.	CDC	1133309	-	20260111	0.10	20050902	\$37.50	\$1,000.00	\$0.00
Casa Berardi Regional	Hecla Québec Inc.	CDC	1133310	-	20260111	55.87	20050902	\$73.25	\$2,500.00	\$48,925.74
Casa Berardi Regional	Hecla Québec Inc.	CDC	1133311	-	20260111	55.87	20050902	\$73.25	\$2,500.00	\$18,223.53
Casa Berardi Regional	Hecla Québec Inc.	CDC	1133312	-	20260111	55.87	20050902	\$73.25	\$2,500.00	\$84,365.34
Casa Berardi Regional	Hecla Québec Inc.	CDC	1133313	-	20260111	55.87	20050902	\$73.25	\$2,500.00	\$14,574.89
Casa Berardi Regional	Hecla Québec Inc.	CDC	1133314	-	20260111	55.87	20050902	\$73.25	\$2,500.00	\$44,906.41

31-A  
31-A

Casa Berardi Regional	Hecla Québec Inc.	CDC	1133315	-	20260111	30.06	20050902	\$73.25	\$2,500.00	\$1,374.03
Casa Berardi Regional	Hecla Québec Inc.	CDC	1133316	-	20260111	28.05	20050902	\$73.25	\$2,500.00	\$61.84
Casa Berardi Regional	Hecla Québec Inc.	CDC	1133317	-	20260111	27.33	20050902	\$73.25	\$2,500.00	\$0.00
Casa Berardi Regional	Hecla Québec Inc.	CDC	1133318	-	20260111	17.00	20050902	\$37.50	\$1,000.00	\$3,798.08
Casa Berardi Regional	Hecla Québec Inc.	CDC	1133319	-	20260111	55.86	20050902	\$73.25	\$2,500.00	\$18,217.01
Casa Berardi Regional	Hecla Québec Inc.	CDC	1133320	-	20260111	55.86	20050902	\$73.25	\$2,500.00	\$47,123.47
Casa Berardi Regional	Hecla Québec Inc.	CDC	1133321	-	20260111	55.86	20050902	\$73.25	\$2,500.00	\$42,120.43
Casa Berardi Regional	Hecla Québec Inc.	CDC	1133322	-	20260111	55.86	20050902	\$73.25	\$2,500.00	\$18,217.01
Casa Berardi Regional	Hecla Québec Inc.	CDC	1133323	-	20260111	55.86	20050902	\$73.25	\$2,500.00	\$18,217.01
Casa Berardi Regional	Hecla Québec Inc.	CDC	1133324	-	20260111	55.86	20050902	\$73.25	\$2,500.00	\$47,409.72

32-A  
32-A

Casa Berardi Regional	Hecla Québec Inc.	CDC	1133325	-	20260111	55.86	20050902	\$73.25	\$2,500.00	\$38,229.17
Casa Berardi Regional	Hecla Québec Inc.	CDC	1133326	-	20260111	55.86	20050902	\$73.25	\$2,500.00	\$49,890.84
Casa Berardi Regional	Hecla Québec Inc.	CDC	1133327	-	20260111	50.96	20050902	\$73.25	\$2,500.00	\$15,018.14
Casa Berardi Regional	Hecla Québec Inc.	CDC	1133328	-	20260111	41.56	20050902	\$73.25	\$2,500.00	\$42,091.96
Casa Berardi Regional	Hecla Québec Inc.	CDC	1133329	-	20260111	38.98	20050902	\$73.25	\$2,500.00	\$15,118.74
Casa Berardi Regional	Hecla Québec Inc.	CDC	1133330	-	20260111	19.70	20050902	\$37.50	\$1,000.00	\$23,627.26
Casa Berardi Regional	Hecla Québec Inc.	CDC	1133331	-	20260111	55.85	20050902	\$73.25	\$2,500.00	\$18,210.48
Casa Berardi Regional	Hecla Québec Inc.	CDC	1133332	-	20260111	55.85	20050902	\$73.25	\$2,500.00	\$18,210.48
Casa Berardi Regional	Hecla Québec Inc.	CDC	1133333	-	20260111	55.85	20050902	\$73.25	\$2,500.00	\$18,210.48
Casa Berardi Regional	Hecla Québec Inc.	CDC	1133334	-	20260111	55.85	20050902	\$73.25	\$2,500.00	\$18,210.48

33-A  
33-A

Casa Berardi Regional	Hecla Québec Inc.	CDC	1133335	-	20260111	55.85	20050902	\$73.25	\$2,500.00	\$18,210.48
Casa Berardi Regional	Hecla Québec Inc.	CDC	1133336	-	20260111	55.85	20050902	\$73.25	\$2,500.00	\$18,210.48
Casa Berardi Regional	Hecla Québec Inc.	CDC	1133337	-	20260111	55.85	20050902	\$73.25	\$2,500.00	\$18,210.48
Casa Berardi Regional	Hecla Québec Inc.	CDC	1133338	-	20260111	30.34	20050902	\$73.25	\$2,500.00	\$1,556.82
Casa Berardi Regional	Hecla Québec Inc.	CDC	1133339	-	20260111	2.07	20050902	\$37.50	\$1,000.00	\$0.00
Casa Berardi Regional	Hecla Québec Inc.	CDC	1133340	-	20260111	19.63	20050902	\$37.50	\$1,000.00	\$5,515.03
Casa Berardi Regional	Hecla Québec Inc.	CDC	1133341	-	20260111	25.56	20050902	\$73.25	\$2,500.00	\$213,428.07
Casa Berardi Regional	Hecla Québec Inc.	CDC	1133342	-	20260111	7.94	20050902	\$37.50	\$1,000.00	\$0.00
Casa Berardi Regional	Hecla Québec Inc.	CDC	1133343	-	20260111	55.87	20050902	\$73.25	\$2,500.00	\$18,223.53
Casa Berardi Regional	Hecla Québec Inc.	CDC	1133344	-	20260111	55.87	20050902	\$73.25	\$2,500.00	\$346,192.91

34-A  
34-A

Casa Berardi Regional	Hecla Québec Inc.	CDC	1133345	-	20260111	7.93	20050902	\$37.50	\$1,000.00	\$0.00
Casa Berardi Regional	Hecla Québec Inc.	CDC	1133346	-	20260111	55.86	20050902	\$73.25	\$2,500.00	\$18,217.01
Casa Berardi Regional	Hecla Québec Inc.	CDC	1133347	-	20260111	55.86	20050902	\$73.25	\$2,500.00	\$18,217.01
Casa Berardi Regional	Hecla Québec Inc.	CDC	1133348	-	20240202	17.21	20050902	\$37.50	\$1,000.00	\$118,933.76
Casa Berardi Regional	Hecla Québec Inc.	CDC	1133349	-	20240202	19.34	20050902	\$37.50	\$1,000.00	\$28,391.61
Casa Berardi Regional	Hecla Québec Inc.	CDC	1133350	-	20240202	19.04	20050902	\$37.50	\$1,000.00	\$27,853.47
Casa Berardi Regional	Hecla Québec Inc.	CDC	1133351	-	20240202	5.58	20050902	\$37.50	\$1,000.00	\$3,709.27
Casa Berardi Regional	Hecla Québec Inc.	CDC	1133352	-	20240202	42.81	20050902	\$73.25	\$2,500.00	\$140,180.52
Casa Berardi Regional	Hecla Québec Inc.	CDC	1133353	-	20240202	50.64	20050902	\$73.25	\$2,500.00	\$231,644.87
Casa Berardi Regional	Hecla Québec Inc.	CDC	1133354	-	20240202	48.92	20050902	\$73.25	\$2,500.00	\$143,711.70

35-A  
35-A

Casa Berardi Regional	Hecla Québec Inc.	CDC	1133355	-	20240202	15.49	20050902	\$37.50	\$1,000.00	\$21,485.58
Casa Berardi Regional	Hecla Québec Inc.	CDC	1134230	-	20240509	7.97	20051104	\$37.50	\$1,000.00	\$0.00
Casa Berardi Regional	Hecla Québec Inc.	CDC	1134231	-	20240509	5.78	20051104	\$37.50	\$1,000.00	\$0.00
Casa Berardi Regional	Hecla Québec Inc.	CDC	2438781	-	20250329	55.82	20160330	\$73.25	\$1,800.00	\$0.00
Casa Berardi Regional	Hecla Québec Inc.	CDC	2443561	-	20250426	7.99	20160427	\$37.50	\$750.00	\$0.00
Casa Berardi Regional	Hecla Québec Inc.	CDC	2449153	-	20250614	55.89	20160615	\$73.25	\$1,800.00	\$0.00
Casa Berardi Regional	Hecla Québec Inc.	CDC	2491530	-	20240503	55.84	20170504	\$73.25	\$1,200.00	\$0.00
Casa Berardi Regional	Hecla Québec Inc.	CDC	2491531	-	20240503	55.81	20170504	\$73.25	\$1,200.00	\$0.00
Casa Berardi Regional	Hecla Québec Inc.	CDC	2491532	-	20240503	55.80	20170504	\$73.25	\$1,200.00	\$0.00
Casa Berardi Regional	Hecla Québec Inc.	CDC	2491533	-	20240503	55.80	20170504	\$73.25	\$1,200.00	\$0.00

36-A  
36-A

Casa Berardi Regional	Hecla Québec Inc.	CDC	2491534	-	20240503	55.84	20170504	\$73.25	\$1,200.00	\$0.00
Casa Berardi Regional	Hecla Québec Inc.	CDC	2491535	-	20240503	55.84	20170504	\$73.25	\$1,200.00	\$0.00
Casa Berardi Regional	Hecla Québec Inc.	CDC	2491536	-	20240503	55.84	20170504	\$73.25	\$1,200.00	\$0.00
Casa Berardi Regional	Hecla Québec Inc.	CDC	2491537	-	20240503	55.84	20170504	\$73.25	\$1,200.00	\$0.00
Casa Berardi Regional	Hecla Québec Inc.	CDC	2491538	-	20240503	55.84	20170504	\$73.25	\$1,200.00	\$0.00
Casa Berardi Regional	Hecla Québec Inc.	CDC	2491539	-	20240503	55.83	20170504	\$73.25	\$1,200.00	\$0.00
Casa Berardi Regional	Hecla Québec Inc.	CDC	2491540	-	20240503	55.83	20170504	\$73.25	\$1,200.00	\$0.00
Casa Berardi Regional	Hecla Québec Inc.	CDC	2491541	-	20240503	55.83	20170504	\$73.25	\$1,200.00	\$0.00
Casa Berardi Regional	Hecla Québec Inc.	CDC	2491542	-	20240503	55.83	20170504	\$73.25	\$1,200.00	\$0.00
Casa Berardi Regional	Hecla Québec Inc.	CDC	2491543	-	20240503	55.83	20170504	\$73.25	\$1,200.00	\$0.00

37-A  
37-A

Casa Berardi Regional	Hecla Québec Inc.	CDC	2491544	-	20240503	55.83	20170504	\$73.25	\$1,200.00	\$0.00
Casa Berardi Regional	Hecla Québec Inc.	CDC	2491545	-	20240503	55.83	20170504	\$73.25	\$1,200.00	\$0.00
Casa Berardi Regional	Hecla Québec Inc.	CDC	2491546	-	20240503	55.83	20170504	\$73.25	\$1,200.00	\$0.00
Casa Berardi Regional	Hecla Québec Inc.	CDC	2491547	-	20240503	55.83	20170504	\$73.25	\$1,200.00	\$0.00
Casa Berardi Regional	Hecla Québec Inc.	CDC	2491548	-	20240503	55.83	20170504	\$73.25	\$1,200.00	\$0.00
Casa Berardi Regional	Hecla Québec Inc.	CDC	2491549	-	20240503	55.83	20170504	\$73.25	\$1,200.00	\$0.00
Casa Berardi Regional	Hecla Québec Inc.	CDC	2491550	-	20240503	55.83	20170504	\$73.25	\$1,200.00	\$0.00
Casa Berardi Regional	Hecla Québec Inc.	CDC	2491551	-	20240503	55.82	20170504	\$73.25	\$1,200.00	\$0.00
Casa Berardi Regional	Hecla Québec Inc.	CDC	2491552	-	20240503	55.82	20170504	\$73.25	\$1,200.00	\$0.00
Casa Berardi Regional	Hecla Québec Inc.	CDC	2491553	-	20240503	55.82	20170504	\$73.25	\$1,200.00	\$0.00

38-A  
38-A

Casa Berardi Regional	Hecla Québec Inc.	CDC	2491554	-	20240503	55.82	20170504	\$73.25	\$1,200.00	\$0.00
Casa Berardi Regional	Hecla Québec Inc.	CDC	2491555	-	20240503	55.82	20170504	\$73.25	\$1,200.00	\$0.00
Casa Berardi Regional	Hecla Québec Inc.	CDC	2491556	-	20240503	55.82	20170504	\$73.25	\$1,200.00	\$0.00
Casa Berardi Regional	Hecla Québec Inc.	CDC	2491557	-	20240503	55.82	20170504	\$73.25	\$1,200.00	\$0.00
Casa Berardi Regional	Hecla Québec Inc.	CDC	2491558	-	20240503	55.82	20170504	\$73.25	\$1,200.00	\$0.00
Casa Berardi Regional	Hecla Québec Inc.	CDC	2491559	-	20240503	55.82	20170504	\$73.25	\$1,200.00	\$0.00
Casa Berardi Regional	Hecla Québec Inc.	CDC	2491560	-	20240503	55.82	20170504	\$73.25	\$1,200.00	\$0.00
Casa Berardi Regional	Hecla Québec Inc.	CDC	2491561	-	20240503	55.82	20170504	\$73.25	\$1,200.00	\$0.00
Casa Berardi Regional	Hecla Québec Inc.	CDC	2491562	-	20240503	55.82	20170504	\$73.25	\$1,200.00	\$0.00
Casa Berardi Regional	Hecla Québec Inc.	CDC	2491563	-	20240503	55.82	20170504	\$73.25	\$1,200.00	\$0.00

39-A  
39-A

Casa Berardi Regional	Hecla Québec Inc.	CDC	2491564	-	20240503	55.82	20170504	\$73.25	\$1,200.00	\$0.00
Casa Berardi Regional	Hecla Québec Inc.	CDC	2491565	-	20240503	55.82	20170504	\$73.25	\$1,200.00	\$0.00
Casa Berardi Regional	Hecla Québec Inc.	CDC	2491566	-	20240503	55.82	20170504	\$73.25	\$1,200.00	\$0.00
Casa Berardi Regional	Hecla Québec Inc.	CDC	2491567	-	20240503	55.81	20170504	\$73.25	\$1,200.00	\$0.00
Casa Berardi Regional	Hecla Québec Inc.	CDC	2491568	-	20240503	55.81	20170504	\$73.25	\$1,200.00	\$0.00
Totals		CDC	2491569	-	20240503	55.81	20170504	\$73.25	\$1,200.00	\$0.00

40-A  
40-A

# APPENDIX B

## Drill-Hole and Rock-Chip Sample Database Structures

1-B  
1-B

RSI-M0206.22001

---

# APPENDIX b: Drill-Hole and Rock-Chip Sample Database Structures

## B.1 Drill-Hole and Rock-Chip Sample Database Structures

Table	Description	Main Fields
<b>Drill-Hole Sample Database</b>		
Header	Collar table	Hole_Id, Hole_Type, Max_Depth, Orig_Grid_Id, X, Y, Z, Orig_Survey_Method, Orig_Survey_Date, Orig_Survey_By, Orig_Survey_Company, Lease_Id, Prospect, Hole_Status, Date_Started, Date_Completed, Validated, Validated_Date, Validated_By, Responsible_Person, Historic_Hole_Id, Hole_Purpose, Map_Sheet, Target, Hole_Cemented, Equipment_In_Hole, Casing_Pulled, Casing_Length, Water_Intersected, Hole_Location, Plugged, File_Location, Program_Type, Comments
Survey	Deviation tests	Hole_Id, Depth, Survey_Method, Dip, Azimuth, Mag, Mag_Dip, Gravity, Date_Surveyed, Survey_Company, Survey_Operator, Survey_Instrument, Comments, Deviation, Data_Quality, Priority
Assay	Gold assay results	SampleID, Hole_ID, Depth_From, Depth_To, Sample_Type, Au_Batch_No, Au_GenericMethod, Au_ppm, Sampled_Date, Sampled_By, Comments, OR_TRA_Def_ppm, As_ppm
Lithology	Lithology main table	Hole_Id, Depth_From, Depth_To, Interval_Length, Priority, Lith_Plot, Lith1_Code, Lith1_Texture, Lith1_Structure, Lith1_Grainsize, Lith_Description, Colour_Description, Relogged_By, Comments, Data_Source, Logged_By, Logged_Date
Mineral0	Mineral Table Main	Hole_Id, Depth_From, Depth_To, Interval_Length, Priority, Min1_Code, Min1_Pct, Min1_Style, Min2_Code, Min2_Pct, Min2_Style, Min3_Code, Min3_Pct, Min3_Style, Min4_Code, Min4_Pct, Min4_Style, Min5_Code, Min5_Pct, Min5_Style, Comments, Logged_Date, Nom_Complet, Data_Source

2-B  
2-B

Structure0	Structure Main Table	Hole_Id, Depth_From, Depth_To, Interval_Length, Structure_Type, Priority, True_Width, Structure_Class, Younging_Indicator, Plane_Type, Plane_Intensity, Plane_Azimuth, Plane_Dip, Lineation_Type, Lineation_Trend, Lineation_Plunge, Lineation_Delta, Kinematic_Indicator, Movement_Sense, Computed_Plane_Azimuth, Computed_Plane_Dip, Computed_Lineation_Trend, Computed_Lineation_Plunge, Comments, Core_Angle, Data_Source
Vein0	Vein Main Table	Hole_ID, Depth_From, Depth_To, Interval_Length, Priority, Vein1_Code, Vein1_Style, Vein1_Pct, Vein1_Core_Angle, Vein1_Colour, Vein1_Colour_Tone, Vein1_Min1_Code, Vein1_Min1_Pct, Vein1_Min2_Code, Vein1_Min2_Pct, Vein1_Min3_Code, Vein1_Min3_Pct, Vein2_Code, Vein2_Style, Vein2_Pct, Vein2_Core_Angle, Vein2_Colour, Vein2_Colour_Tone, Vein2_Min1_Code, Vein2_Min1_Pct, Vein2_Min2_Code, Vein2_Min2_Pct, Vein2_Min3_Code, Vein2_Min3_Pct, Vein3_Code, Vein3_Style, Vein3_Pct, Vein3_Core_Angle, Vein3_Colour, Vein3_Colour_Tone, Vein3_Min1_Code, Vein3_Min1_Pct, Vein3_Min2_Code, Vein3_Min2_Pct, Vein3_Min3_Code, Vein3_Min3_Pct, Description, Data_Source
<b>Rock-Chip Sample Database</b>		
Table	Description	Main Fields
Collar	Main table	Hole_id, X, Y, Z, Max_depth, Azimuth, Dip
Survey	Deviation Tests	Hole_id, Depth, Dip, Azimuth
Assays	Gold Results Assay	Hole_id, Depth_from, Depth_to, Samp_id, Or_tra, Tag, Geo, Geo_1, Geo_2
Litho_0	Geology Main Table	Hole_id, Depth_from, Depth_to, TITRE, DESCRIPTIO, SELECTCODE, CODE_TRACE, SU_TYPE, VEINE_TYPE, ALT_TYPE, DEF_TYPE

3-B  
3-B

# APPENDIX C

## Capping Levels

1-C

1-C

# APPENDIX C: Capping Levels

## C.1 Capping Levels

Zone	Location	Lens Numbers	Core Capping Levels (g/t Au)	Chip Capping Levels (g/t Au)
104	Underground	03, 04	No capping	No capping
107	UNDERGROUND	02, 03	18.5	42
Inter	UNDERGROUND	01, 02, 04	18	18
105	OPEN PIT	01	46	46
105	OPEN PIT	02	51	51
105	OPEN PIT	03	11	11
105	OPEN PIT	04	19	19
105	OPEN PIT	06	No capping	No capping
114	OPEN PIT	01	16	16
Lower Inter	UNDERGROUND	01	120	120
109	UNDERGROUND	01, 02, 03, 04, 05, 06	45	45
113	UNDERGROUND	Main, 05, 07	175	100
113	UNDERGROUND	04	35	35
113	UNDERGROUND	06	50	50
113	UNDERGROUND	12	14	14
113	UNDERGROUND	41, 42, 43, 44	17	17
113	UNDERGROUND	61	No capping	No capping
115	UNDERGROUND	01	100	100
115	UNDERGROUND	02, 03, 04, 05, 06	50	50
116	UNDERGROUND	01	No capping	No capping
117	UNDERGROUND	Main	35	35
118	UNDERGROUND	82,83	14	14
118	UNDERGROUND	09, 34	15	15
118	UNDERGROUND	05	19	19
118	UNDERGROUND	11, 12, 13, 41, 42	24	24
118	UNDERGROUND	47	25	25
118	UNDERGROUND	62, 63, 64	34	34
118	UNDERGROUND	07	40	40
118	UNDERGROUND	10	43	36

2-C  
2-C

Zone	Location	Lens Numbers	Core Capping Levels (g/t Au)	Chip Capping Levels (g/t Au)
118	UNDERGROUND	06	45	45
118	UNDERGROUND	20, 21, 22, 27	50	40
118	UNDERGROUND	31	51	50
118	UNDERGROUND	43, 44, 45	65	65
118	UNDERGROUND	14,15,16,17,18,81	No capping	No capping
119	UNDERGROUND	01	20	20
119	UNDERGROUND	02	No capping	No capping
119	UNDERGROUND	03, 04	14	No capping
119	UNDERGROUND	05	11	11
119	UNDERGROUND	06	13	13
119	UNDERGROUND	07	12	12
121	UNDERGROUND	01, 02	30	30
123	UNDERGROUND	09	12	12
123	UNDERGROUND	10, 14	14	14
123	UNDERGROUND	15, 16	16	16
123	UNDERGROUND	19	22	22
123	UNDERGROUND	12	32	27
123	UNDERGROUND	05	39	40
123	UNDERGROUND	04	42	42
123	UNDERGROUND	03	64	40
123	UNDERGROUND	01	68	68
123	UNDERGROUND	02	70	68
123	UNDERGROUND	17,18	No Capping	No Capping
123	OPEN PIT	23	06	06
123	OPEN PIT	21	08	08
123	OPEN PIT	09	13	13
123	OPEN PIT	05	39	39
123	OPEN PIT	17, 18, 22, 24,25	No Capping	No Capping
124	UNDERGROUND	52, 61	15	15
124	UNDERGROUND	30	20	20
124	UNDERGROUND	17	30	20
124	UNDERGROUND	86	30	30
124	UNDERGROUND	40, 41, 42 ,43	35	35
124	UNDERGROUND	81, 82, 87	45	45

3-C  
3-C

Zone	Location	Lens Numbers	Core Capping Levels (g/t Au)	Chip Capping Levels (g/t Au)
124	UNDERGROUND	83	45	48
124	UNDERGROUND	84	45	16
124	UNDERGROUND	85	45	20
124	UNDERGROUND	12	64	64
124	UNDERGROUND	13	64	17
124	UNDERGROUND	22	66	66
124	UNDERGROUND	15, 16	75	75
124	UNDERGROUND	11, 18, 19, 32, 33, 35, 36, 37	No Capping	No Capping
124	OPEN PIT	32	6	6
124	OPEN PIT	31, 36	7	7
124	OPEN PIT	33, 37 51, 52	9	9
124	OPEN PIT	14, 20 35, 38	10	10
124	OPEN PIT	11	11	11
124	OPEN PIT	87	12	12
124	OPEN PIT	86	17	17
124	OPEN PIT	15	18	18
124	OPEN PIT	30	20	20
124	OPEN PIT	41, 43	33	33
124	OPEN PIT	81	46	46
124	OPEN PIT	13	66	66
124	OPEN PIT	22	67	67
124	OPEN PIT	62	No Capping	No Capping
128	UNDERGROUND	01	18	18
129	UNDERGROUND	01	No capping	No capping
134	OPEN PIT	02	9	9
134	OPEN PIT	01	16	16
134	OPEN PIT	05	17	17
134	OPEN PIT	4	19	19
134	OPEN PIT	08, 09, 10	No Capping	No Capping
139	UNDERGROUND	01	No capping	No capping
146	UNDERGROUND	08	8	8
146	UNDERGROUND	09	14	14
146	UNDERGROUND	01, 03, 05, 06, 07, 10	No Capping	No Capping
146	OPEN PIT	01	No Capping	No Capping

4-C  
4-C

Zone	Location	Lens Numbers	Core Capping Levels (g/t Au)	Chip Capping Levels (g/t Au)
146	OPEN PIT	03, 04	8	8
148	UNDERGROUND	19, 20	8	8
148	UNDERGROUND	21, 22	9	9
148	UNDERGROUND	24	11	11
148	UNDERGROUND	10	13	13
148	UNDERGROUND	09	14	14
148	UNDERGROUND	05, 25	18	18
148	UNDERGROUND	01	54	-
148	UNDERGROUND	08	20	20
148	UNDERGROUND	01, 02, 03, 04, 05, 07	50	50
148	UNDERGROUND	18	No Capping	No Capping
148	OPEN PIT	14, 16	3	3
148	OPEN PIT	11	5	5
148	OPEN PIT	07, 08	12	12
148	OPEN PIT	09	14	14
148	OPEN PIT	03	20	20
148	OPEN PIT	01, 04	36	36
148	OPEN PIT	02, 06, 12, 13	50	50
148	OPEN PIT	17	No Capping	No Capping
152	UNDERGROUND	05	8	8
152	UNDERGROUND	01	20	13
152	UNDERGROUND	02, 03	20	20
152	UNDERGROUND	09	No Capping	No Capping
152	UNDERGROUND	06	10	10
152	OPEN PIT	08	3.7	3.7
152	OPEN PIT	02	5.3	5.3
152	OPEN PIT	01, 03, 06	10	10
152	OPEN PIT	07	50	50
157	UNDERGROUND	01, 02, 03	12	12
159	UNDERGROUND	03	12	12
159	UNDERGROUND	01	15	15
159	UNDERGROUND	04	No capping	No capping
159	OPEN PIT	03, 06	8	8
159	OPEN PIT	04, 05	12	12

5-C  
5-C

<b>Zone</b>	<b>Location</b>	<b>Lens Numbers</b>	<b>Core Capping Levels (g/t Au)</b>	<b>Chip Capping Levels (g/t Au)</b>
159	OPEN PIT	01	15	15
159	OPEN PIT	02	18	18
160	UNDERGROUND	05, 09	12	12
160	UNDERGROUND	01, 03	17	17
160	UNDERGROUND	04	22	22
160	OPEN PIT	06	7	7
160	OPEN PIT	03	16	16
160	OPEN PIT	01	23	23
160	OPEN PIT	07	27	27
160	OPEN PIT	04	28	28

6-C  
6-C

# APPENDIX D

## Comparison of 2023 and 2022 Mineral resource Estimates

1-D  
1-D

# APPENDIX D: Comparison of 2023 and 2022 Mineral resource Estimates

## D.1 Mineral Resource Estimates

Classification and Mine Zone	December 31, 2023			December 31, 2022			Gain (Loss)	
	K Tonnes	Grade (g/t Au)	Contained Metal (K oz Au)	K Tonnes	Grade (g/t Au)	Contained Metal (K oz Au)	K Tonnes	Ounces (K oz Au)
<b>Measured</b>								
<b>Underground</b>								
100 Lower Inter	120	8.63	33.3	160	8.38	43.1	(39.93)	(9.81)
101 North West	-	-	-	42	6.41	8.6	(41.56)	(8.56)
107	132	5.50	23.4	151	5.35	26.0	(18.96)	(2.64)
108	1	4.32	0.2	1	5.55	0.2	0.01	(0.05)
109	13	7.65	3.2	26	6.89	5.8	(13.46)	(2.67)
111	-	-	-	-	-	-	-	-
113	334	7.50	80.5	483	7.97	123.7	(149.51)	(43.24)
115	36	6.57	7.7	37	6.75	8.0	(0.56)	(0.33)
117	-	-	-	5	6.72	1.1	(5.02)	(1.09)
118	139	6.52	29.1	313	7.25	73.0	(174.59)	(43.96)
121	-	-	-	-	-	-	-	-
123	114	6.23	22.9	409	6.93	91.2	(295.20)	(68.30)
124	44	5.94	8.3	165	6.15	32.5	(121.08)	(24.22)
148	71	11.88	26.9	421	8.64	116.9	(350.22)	(89.92)
152	-	-	-	-	0.00	-	-	-
Total Underground	1,003	7.30	235.4	2,440	5.08	530.2	(1,333.90)	(294.80)
<b>Open Pit</b>								
WMCP	410	1.39	18.2	438	1.39	19.5	(28)	(1.3)
Principal	0	1.32	0.0	-	-	-	0	0.0
EMCP	-	-	-	0	1.37	0.0	0	(0.0)
160	-	-	-	-	-	-	-	-
Total Open Pit	410	1.39	18.2	438	1.39	19.5	(28)	(1.3)

2-D  
2-D

Classification and Mine Zone	December 31, 2023			December 31, 2022			Gain (Loss)	
	K Tonnes	Grade (g/t Au)	Contained Metal (K oz Au)	K Tonnes	Grade (g/t Au)	Contained Metal (K oz Au)	K Tonnes	Ounces (K oz Au)
Total Measured	1,413	5.58	253.6	2,878	6.45	549.7	(1,362)	(296.1)
<b>Indicated</b>								
<b>Underground</b>								
100 Lower Inter	7	5.93	1.3	1	4.58	0.1	5.86	1.2
107	95	4.73	14.5	96	4.70	14.5	(1.11)	(0.1)
108	1	4.02	0.1	0	0.00	0.0	1.03	0.1
109	61	9.06	17.6	61	9.00	17.7	(0.72)	(0.1)
113	323	6.99	72.6	214	5.38	37.0	109.10	35.6
115	3	5.38	0.4	2	5.71	0.4	0.23	0.0
118	870	6.99	168.8	1,012	5.80	188.7	(142.05)	(19.9)
119	150	6.12	29.5	145	5.92	27.6	4.44	1.8
121	18	5.74	3.3	8	6.25	1.7	9.84	1.7
123	501	6.40	103.0	433	5.69	79.2	68.28	23.8
124	4.95	5.76	91.6	530	5.56	94.8	(35.56)	(3.2)
128	61	5.35	10.5	64	5.28	10.9	(3.26)	(0.4)
134	30	6.68	6.4	104	5.29	17.8	(74.27)	(11.3)
146	13	6.40	2.8	63	5.17	10.5	(49.70)	(7.7)
148	200	11.18	71.8	331	7.55	80.3	(130.94)	(8.5)
152	0	0.00	0.0	80	5.45	14.0	(79.77)	(14.0)
159	21	7.15	4.9	75	6.16	14.8	(53.55)	(9.9)
160	14	7.34	3.4	292	5.32	49.9	(277.75)	(46.6)
Total Underground	2,861	6.55	602.5	3,511	5.85	659.9	(649.88)	(57.4)
<b>Open Pit</b>								
WMCP	71	0.89	2.0	202	1.39	9.0	(132)	(7.0)
148_EMCP	-	-	-	11	1.36	0.5	(11)	(0.5)
Principal	463	0.70	10.4	375	1.38	16.6	88	(6.2)
134	2	0.91	0.1	3	1.40	0.1	(1)	(0.1)
160	235	0.67	5.1	609	1.10	21.6	(375)	(16.5)
Total Open Pit	770	0.71	17.6	1,200	1.24	47.8	(430)	(30.2)

3-D  
3-D

Classification and Mine Zone	December 31, 2023			December 31, 2022			Gain (Loss)	
	K Tonnes	Grade (g/t Au)	Contained Metal (K oz Au)	K Tonnes	Grade (g/t Au)	Contained Metal (K oz Au)	K Tonnes	Ounces (K oz Au)
Total Indicated	3,632	5.31	620.1	4,711	4.67	707.8	(1,080)	(87.6)
Total Measured and Indicated	4,759	5.61	858.3	7,589	5.31	1257.5	(2,728)	(399.1)
<b>Inferred</b>								
<b>Underground</b>								
100 Lower Inter	5	14.16	2.2	5	14.06	2.2	(0.04)	(0.01)
104	85	5.70	15.6	96	5.48	16.9	(10.82)	(1.31)
107	0	4.02	0.0	0	3.83	0.0	(0.22)	(0.03)
108	6	4.65	0.8	3	4.69	0.5	2.21	0.33
113	89	6.98	20.0	150	5.47	26.5	(61.28)	(6.47)
116	214	13.29	91.5	213	13.36	91.3	1.66	0.21
118	182	6.23	36.4	190	6.02	36.8	(8.47)	(0.41)
119	55	5.65	10.0	60	5.55	10.6	(4.28)	(0.58)
121	8	5.22	1.4	2	4.55	0.2	6.69	1.16
123	233	6.43	48.2	230	6.29	46.5	3.59	1.79
124	150	6.14	29.6	154	6.04	29.9	(3.82)	(0.28)
129	56	7.03	12.7	57	6.98	12.8	(0.80)	(0.10)
134	25	7.13	5.7	85	5.28	14.4	(59.90)	(8.70)
139	96	7.80	23.9	182	6.26	36.7	(86.91)	(12.76)
146	15	6.11	2.9	53	5.11	8.8	(38.69)	(5.88)
148	55	9.44	16.8	121	6.35	24.8	(66.07)	(8.01)
152	12	7.78	2.9	26	7.88	6.7	(14.70)	(3.76)
157	3	6.67	0.6	9	5.62	1.6	(6.43)	(1.08)
159	17	6.55	3.6	242	5.24	40.8	(225.02)	(37.21)
160	33	6.47	6.8	136	5.15	22.5	(103.26)	(15.70)
Total Underground	1,338	7.71	331.6	2,015	6.64	430.4	(676.57)	(98.79)
<b>Open Pit</b>								
WMCP	54	1.75	3.1	61	2.14	4.2	(6)	(1.1)
Principal	651	2.50	53.0	453	3.69	53.6	199	(0.7)

4-D  
4-D

Classification and Mine Zone	December 31, 2023			December 31, 2022			Gain (Loss)	
	K Tonnes	Grade (g/t Au)	Contained Metal (K oz Au)	K Tonnes	Grade (g/t Au)	Contained Metal (K oz Au)	K Tonnes	Ounces (K oz Au)
134 (in reserve pit shell)	4	2.58	0.3	2	4.69	0.3	2	0.0
134 (below reserve pit shell)	0	0.00	0.0	938	1.86	56.2	(938)	(56.2)
160 (in reserve pit design)	181	1.93	11.2	167	2.31	12.4	(14)	(1.2)
160 (below reserve pit design)	0	0.00	0.0	5,481	1.49	262.6	(5,481)	(262.6)
Total Open Pit	982	2.36	67.6	7,828	1.71	389.4	(6,211)	(321.8)
Total Inferred Mineral Resources	2,457	5.57	399.2	10,049	2.80	819.8	(6,888)	(420.6)

Notes:

- The 2022 Mineral Resources are superseded by the current 2023 Mineral Resources and are not relied upon by Hecla or RESPEC. RESPEC has not reviewed the 2022 Mineral Resource models or estimates.
- The 2023 Mineral Resources are entirely attributable to Hecla.
- The 2023 Mineral Resources are classified in accordance with the S-K 1300 classification system.
- The 2023 Mineral Resources were estimated by Hecla staff and reviewed and accepted by RESPEC.
- The 2023 Mineral Resources are exclusive of Mineral Reserves and do not have demonstrated economic viability.
- The 2023 underground Mineral Resources are reported at cutoff grades ranging from 3.78g/t Au to 5.84g/t Au.
- The 2023 open pit Mineral Resources are reported at cutoff grades ranging from 0.97g/t Au to 1.13g/t Au.
- The 2023 underground and open pit Mineral Resources are estimated using US\$1,750/oz Au, based on consensus, long term forecasts from banks, financial institutions, and other sources, and a US\$/C\$ exchange rate of 1.300.
- A minimum mining width of three meters was used for the modeled open pit and underground mineral envelopes used to estimate the 2023 Mineral Resources.
- Totals in the 2023 Mineral Resources may not represent the sum of the parts due to rounding.
- The 2023 Mineral Resources potentially amenable to open pit mining methods are reported using a gold price of US\$1,750/oz, a throughput rate of 4,400 tonnes/day (combined material from underground and open pit sources), surface mining costs of US\$3.46/tonne mined, milling processing costs of US\$24.13/tonne processed, and general and administrative and other costs ranging from \$9.96-10.34/tonne processed. Metallurgical recoveries were based on metallurgical curves.
- The 2023 Mineral Resources potentially amenable to underground mining methods are reported using a gold price of US\$1,750/oz and a throughput rate of 4,400 tons/day (combined material from underground and open pit sources). Operating costs are US\$183.08/ton mined or US\$282.60/ton mined, depending on the underground zone or lens. Mill recoveries also vary by zone or lens and range from 80.10% to 89.90%.

5-D  
5-D